

# SERVICE MANUAL

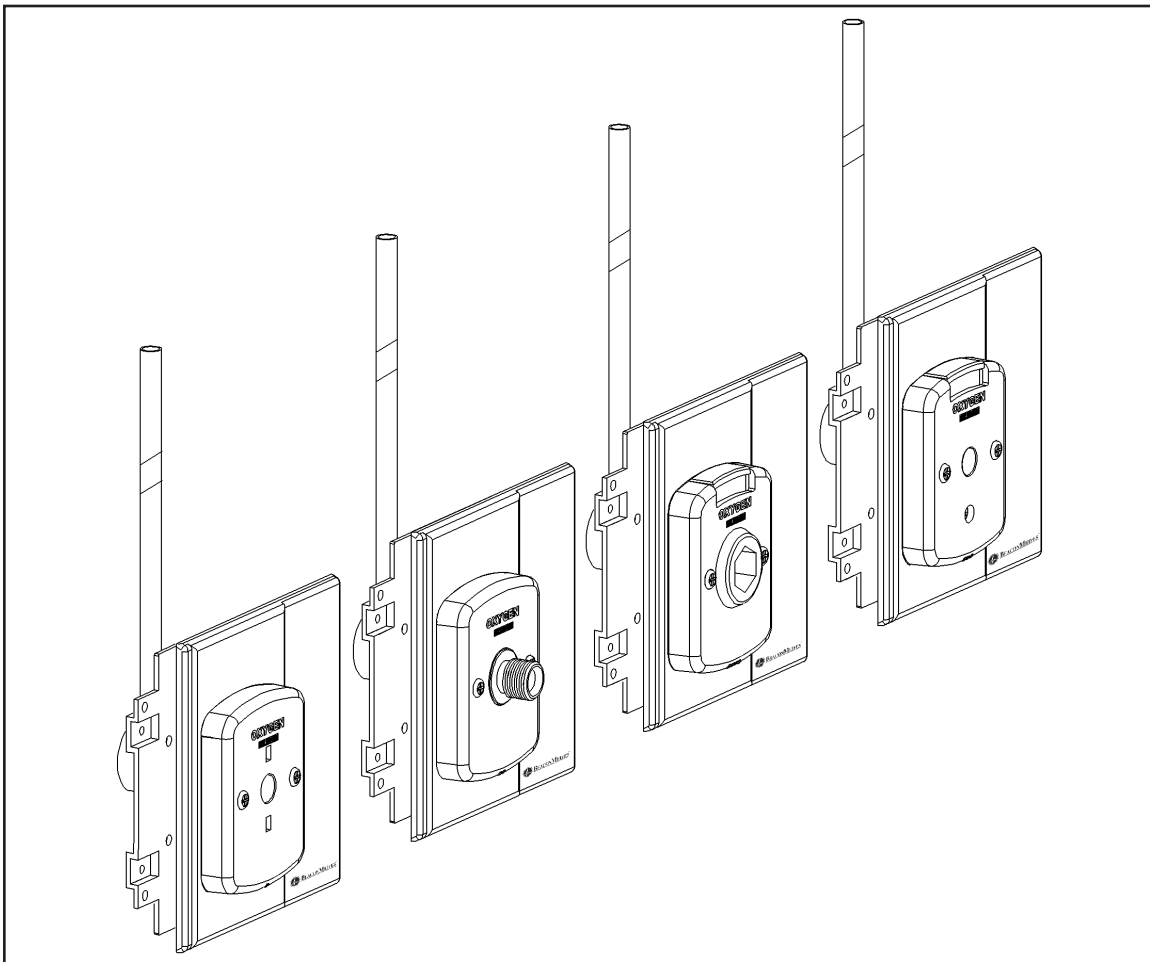

**BEACONMEDÆS™**

## **DiamondCare® Recessed Wall Outlet and Electrical**



**For Parts or Technical Assistance**

**MAN01-045 Rev. B**

Technical Support: 1-888-4MEDGAS (463-3427)

Customer Service: 1-888-4MEDGAS (463-3427)

[www.beaconmedaes.com](http://www.beaconmedaes.com)

©2004 by BeaconMedæs. ALL RIGHTS RESERVED.

No part of this text shall be reproduced or transmitted in any form or by any means, electronic or mechanical, including photocopying, recording, or by any information or retrieval system without written permission from BeaconMedæs.

First Edition

First Printing 2004

Printed in the USA

CSA® is a registered trademark of Canadian Standards Association.

Decora® is a registered trademark of Leviton Manufacturing Co., Inc.

Diamond® is a trademark of BeaconMedæs.

DiamondCare® is a trademark of BeaconMedæs.

Krytox® is a registered trademark of E. I. du Pont and de Nemours and Company.

The information contained in this manual is subject to change without notice. BeaconMedæs makes no commitment to update or keep current, the information contained in this manual.

The only product warranty intended by BeaconMedæs is the express, written warranty accompanying the bill of sale to the original purchaser. BeaconMedæs makes no other warranty, express or implied, and in particular, makes no warranty of merchantability or fitness for a particular purpose.

# Table of Contents

## Chapter 1 Introduction

Purpose .....	1-3
Audience .....	1-3
Organization .....	1-3
Chapter 1: Introduction .....	1-3
Chapter 2: Troubleshooting Procedures .....	1-3
Chapter 3: Theory of Operation .....	1-3
Chapter 4: Removal, Replacement, and Adjustment Procedures .....	1-3
Chapter 5: Parts List .....	1-3
Chapter 6: General Procedures .....	1-3
Typographical Conventions .....	1-4
Terminology .....	1-5
Definitions .....	1-5
Acronyms .....	1-5
Introduction .....	1-6
Operating Precautions .....	1-7
Specifications .....	1-8
Physical Description .....	1-8
Rough-In Assembly .....	1-8
Finish Assembly .....	1-8
Regulations, Standards, and Codes .....	1-9
System Features .....	1-9
Key Style Identification .....	1-10
Assembly Identification .....	1-11
Wall Outlet Rough-In Assemblies .....	1-11
Wall Outlet Finish Assemblies .....	1-12
Safety Tips .....	1-13
Warning and Caution Labels .....	1-16

## **Chapter 2 Troubleshooting Procedures**

Getting Started.....	2-2
Initial Actions .....	2-2
Function Checks .....	2-3
Final Actions.....	2-4
Test Equipment.....	2-4
DISS Key Style Medical Gas Wall Outlet Leakage.....	2-5
Diamond®, Latch Index, or Geometric Key Style Medical Gas Wall Outlet Leakage.....	2-5
Attachment Malfunction.....	2-6
Rough-In Assembly Leakage (Pressurized Medical Gases) .....	2-7
Rough-In Assembly Leakage (Vacuum Outlets Only).....	2-7

## **Chapter 3 Theory of Operation**

Theory of Operation .....	3-2
Hardware .....	3-2
Quick-Connect Key Style Outlets .....	3-2
DISS Key Style Outlets.....	3-2

## **Chapter 4 Removal, Replacement, and Adjustment Procedures**

Frontbody Assembly.....	4-3
Removal.....	4-3
Replacement .....	4-3
Twist-Lock Replaceable Barrel Assembly .....	4-4
Removal.....	4-4
Replacement .....	4-4
Rough-In Secondary Check Unit Assembly (Pressurized Outlets Only) .....	4-6
Removal.....	4-6
Replacement .....	4-7
Rough-In Assembly (Vacuum Outlets Only) .....	4-8
Removal.....	4-8
Replacement .....	4-8
DISS Key Style Frontbody Assembly .....	4-10

Removal.....4-10

Replacement .....4-11

Diamond® Quick-Connect Key Style Frontbody Assembly .....4-12

Removal.....4-12

Replacement .....4-13

Latch Index Quick-Connect Key Style Frontbody Assembly.....4-15

Removal.....4-15

Replacement .....4-16

Geometric Quick-Connect Key Style Frontbody Assembly .....4-17

Removal.....4-17

Replacement .....4-18

**Chapter 5 Parts List**

Warranty .....5-3

Service Parts Ordering.....5-5

Recommended Spare Parts.....5-5

DISS Key Style Finish Assembly.....5-6

Diamond® Quick-Connect Key Style Finish Assembly.....5-8

Latch Index Quick-Connect Key Style Finish Assembly .....5-10

Geometric Quick-Connect Key Style Finish Assembly.....5-12

Gas Service Rough-In Assembly.....5-14

Twist-Lock Finish Assembly .....5-16

Power Drop Straight Blade Finish Assembly.....5-17

Duplex Receptacle Finish Assembly .....5-18

Outlet—GFCI Finish Assembly .....5-19

Toggle Switch Finish Assembly.....5-20

Decora® Switch Finish Assembly .....5-21

Low Voltage Switch Finish Assembly .....5-22

Blank Provision Finish Assembly .....5-23

Electrical Accessories Rough-In Assembly.....5-24

Recessed Wall Slide Finish Assembly.....5-25

Recessed Wall Blank Finish Assembly .....5-26

Recessed Wall Slide Rough-In Assembly .....5-27

Wall-Mounted Slide Finish Assembly with Anchors .....5-28

Surface-Mounted Gas Outlet Enclosure.....5-29

Surface-Mounted Slide Enclosure.....5-30

Replacement Twist-Lock Barrel Assembly Repair Kits .....5-31

Frontbody Repair Parts Kits.....5-32

Rough-In Assembly Repair Parts Kits .....5-33

DiamondCare® Conversion Kits .....5-34

**Chapter 6 General Procedures**

Cleaning.....6-2

    Steam Cleaning.....6-2

    Cleaning Hard to Clean Spots .....6-2

    Disinfection .....6-2

Component Handling.....6-3

Lubrication Requirements .....6-3

Service .....6-4

Repair Policy and Procedure .....6-5

Repair Kits.....6-6

General Service Procedures.....6-7

Tool and Supply Requirements .....6-8

# Chapter 1 Introduction

# 1

## Chapter Contents

Purpose .....	1-3
Audience.....	1-3
Organization .....	1-3
Chapter 1: Introduction .....	1-3
Chapter 2: Troubleshooting Procedures .....	1-3
Chapter 3: Theory of Operation .....	1-3
Chapter 4: Removal, Replacement, and Adjustment Procedures .....	1-3
Chapter 5: Parts List.....	1-3
Chapter 6: General Procedures.....	1-3
Typographical Conventions.....	1-4
Terminology.....	1-5
Definitions .....	1-5
Acronyms.....	1-5
Introduction .....	1-6
Operating Precautions .....	1-7
Specifications.....	1-8
Physical Description.....	1-8
Rough-In Assembly .....	1-8
Finish Assembly .....	1-8
Regulations, Standards, and Codes .....	1-9
System Features.....	1-9
Key Style Identification.....	1-10
Assembly Identification.....	1-11
Wall Outlet Rough-In Assemblies .....	1-11

Wall Outlet Finish Assemblies .....1-12

Safety Tips .....1-13

Warning and Caution Labels .....1-16

---

## **Purpose**

This manual provides requirements for DiamondCare® Medical Gas/Vacuum Recessed Wall Outlets and Electrical Accessories operation and service. It also includes parts lists (in chapter 5) for ordering replacement components.

---

## **Audience**

This manual is intended for use by only facility-authorized personnel. Failure to observe this restriction can result in severe injury to people and serious damage to equipment.

---

## **Organization**

This manual contains seven chapters.

### **Chapter 1: Introduction**

Chapter 1 contains a brief description of this service manual, as well as a product overview.

### **Chapter 2: Troubleshooting Procedures**

Chapter 2 contains repair analysis procedures. Use these procedures to gather information, identify a repair need, and verify the effectiveness of the repair.

### **Chapter 3: Theory of Operation**

Chapter 3 describes the application of the mechanical system employed in this product.

### **Chapter 4: Removal, Replacement, and Adjustment Procedures**

Chapter 4 contains the detailed repair procedures determined necessary in chapter 2.

### **Chapter 5: Parts List**

Chapter 5 contains the warranty, part-ordering procedure, and illustrated parts lists for this product.

### **Chapter 6: General Procedures**

Chapter 6 contains cleaning, servicing, and other general procedures.

## Typographical Conventions

This manual contains different typefaces and icons designed to improve readability and increase understanding of its content. Note the following examples:

- Standard text—used for regular information.
- **Boldface text**—emphasizes a word or phrase.
- **NOTE:**—sets apart special information or important instruction clarification.
- The symbol below highlights a **WARNING** or **CAUTION**:

**Figure 1-1. Warning and Caution**



- A **WARNING** identifies situations or actions that may affect patient or user safety. Disregarding a warning could result in patient or user injury.
- A **CAUTION** points out special procedures or precautions that personnel must follow to avoid equipment damage.

---

## Terminology

### Definitions

- Recessed wall outlet: Medical gas/vacuum outlet intended for in-wall installation. It is designed to be ganged together for placement between wall studs.
- Rough-in assembly: Sub-assembly of the outlet that connects to the facility's piped medical gas system. The rough-in assembly contains the secondary check valve (for pressurized medical gases only).
- Frontbody assembly: Sub-assembly of the outlet that connects to a patient care system. The frontbody consists of the primary check valve and a keying disc. The keying disc contains an adapter release button (for Latch Index Key and Geometric Key key styles), and a gas-specific keying system that prevents cross-connection from the outlet to a patient care system and from the frontbody assembly to the backbody assembly.
- Finish assembly: Assembly that attaches to a rough-in assembly to trim the outlet to the rough wall opening. For example, the recessed outlet finish assembly consists of the frontbody assembly and a finish faceplate.

### Acronyms

- American National Standards Institute (**ANSI**)
- Compressed Gas Association (**CGA**)
- Canadian Standards Association (**CSA**)
- Diameter Index Safety System (**DISS**)
- International Electro-technical Commission (**IEC**)
- National Fire Protection Association (**NFPA**)
- Underwriters Laboratories (**UL**)
- Waste Anesthetic Gas Disposal (**WAGD**)
- Anesthetic Gas Scavenging System (**AGSS**)

## Introduction

DiamondCare® Recessed Wall Outlets provide medical gas or vacuum services in healthcare facilities having in-wall, piped, medical gas or vacuum distribution systems. A wall outlet consists of a rough-in and a finish assembly, keyed to a specific medical gas/vacuum service in order to avoid accidental cross-connection of services (see table 1-1 on page 1–6).

**Table 1-1. Gas Service Options**

Wall Outlet Key Style	Medical Gas Service							
	O <sub>2</sub>	N <sub>2</sub> O	Vac	Air	WAGD ♦	CO <sub>2</sub>	N <sub>2</sub>	O <sub>2</sub> /CO <sub>2</sub>
Diamond® Quick-Connect	x	x	x	x	x	N/A	N/A	N/A
Latch Index Key Quick-Connect	x	x	x	x	x	N/A	N/A	N/A
Geometric Key Quick-Connect	x	x	x	x	x	N/A	N/A	N/A
DISS	x	x	x	x	x	x	x	x
♦ Waste Anesthetic Gas Disposal (formerly Evacuation)								

Each gas-specific rough-in assembly may be combined with any of the following frontbody assemblies of the same gas service. This allows a broad range of flexible solutions to the facility's medical gas needs while maintaining the gas specific integrity of the medical gas delivery system.

- Diamond® Quick-Connect Key Style from BeaconMedæS
- Latch Index Key Quick-Connect Key Style
- Geometric Key Quick-Connect Key Style
- DISS Key Style



All outlets are color-coded and labeled according to NFPA and CSA standards for safety. All outlets are listed by UL and CSA.

DiamondCare® outlets for all pressurized medical gases are rated for a maximum service pressure of 200 psig. They contain both a secondary check valve and a primary check valve. DiamondCare® vacuum inlets consist of a primary check valve only. The primary check valve (located in the frontbody) prevents gas flow when an outlet adapter or patient treatment device is removed from the outlet. The secondary check valve (located in the rough-in assembly) prevents gas flow when the frontbody is removed from a pressure gas rough-in assembly.

## Operating Precautions

Wall Outlets perform in conformity with the description contained in this service manual and accompanying labels and/or inserts when installed, assembled, operated, and repaired in accordance with the instructions provided. Outlets must be checked periodically. Refer to CGA Pamphlet E-10 (1999 Edition), *Maintenance of Medical Gas and Vacuum Systems in Health Care Facilities*. If an outlet does not work, the outlet should not be used. Broken, missing, plainly worn, distorted, or contaminated parts should be replaced immediately. If repair or replacement become necessary, BeaconMedæ's recommends that a phone call or written request for service advice be made to BeaconMedæ's Customer Service. This product and any of its components should be repaired in accordance with written instructions provided by BeaconMedæ's.



### WARNING:

Components of outlets for vacuum service must never be interchanged or used in outlets delivering pressurized gas service. Possibly injury or equipment damage could occur.

Components of outlets for vacuum service must never be interchanged or used in outlets delivering pressurized gas service. The outlet should not be altered without the prior written approval of BeaconMedæ's. The user of this product shall have the sole responsibility for any malfunction that results from improper use, faulty installation, improper repair, damage, or alteration.

## **Specifications**

### **Physical Description**

The DiamondCare® Recessed Wall Outlet consists of a rough-in assembly and a finish assembly.

#### **Rough-In Assembly**

The rough-in assembly consists of a zinc die-cast backplate with mounting flanges on all four sides, a 1/2" (12.7 mm) raised plaster strike, and a non-removable, positive, pin-keying arrangement for each specific service. Identification of each service is permanently cast into the backplate.

The rough-in assembly for all pressurized gas services contains a fully assembled secondary check, which is serviceable completely from the front. This check prevents gas flow when the finish assembly is removed for service. The rough-in inlet is a 7" (18 cm) long, 1/2" (12.7 mm) OD, type K, copper inlet tube, with a plastic dust cap and label identifying the specific gas by name and color. Rotation of the inlet tube allows alignment with system piping for connections.

#### **Finish Assembly**

The finish assembly consists of a light neutral colored, powder-coated, zinc die-cast, finish faceplate, an attached frontbody keying disc assembly, and a barrel assembly which houses the primary check valve. The keying disc assembly is color-coded and labeled with the name of the gas service. A serviceable barrel assembly includes the primary check valve that engages and seals when an adapter or patient treatment device is removed from the outlet.

## Regulations, Standards, and Codes

All DiamondCare® Recessed Wall Outlets are designed and manufactured to applicable NFPA, CGA, and CSA standards:

- NFPA 99 (1999 Edition) *Standard for Health Care Facilities*
- CSA standard Z305.1 *Non-Flammable Medical Gas/Vacuum System Terminal Outlets*
- CSA Z305.5, *Standard for Non-Flammable Medical Gas Piping Systems*
- CGA Pamphlet G-4.1, *Cleaning for Oxygen Service*
- CGA Pamphlet P-2, *Characteristics and Safe Handling of Medical Gases*
- CGA Pamphlet V-5, *Diameter Index Safety System-Non-Interchangeable Low-Pressure Connections for Medical Gas Applications*
- CGA Pamphlet E-10 (1999 Edition), *Maintenance of Medical Gas and Vacuum Systems in Health Care Facilities*

---

## System Features

DiamondCare® Medical Gas Recessed Wall Outlets are available in the following four key styles (see figure 1-2 on page 1-9):

- DISS
- Diamond® Quick-Connect from BeaconMedæx
- Latch Index Key Quick-Connect
- Geometric Key Quick-Connect

**Figure 1-2. DiamondCare® Recessed Wall Outlet Key Styles**

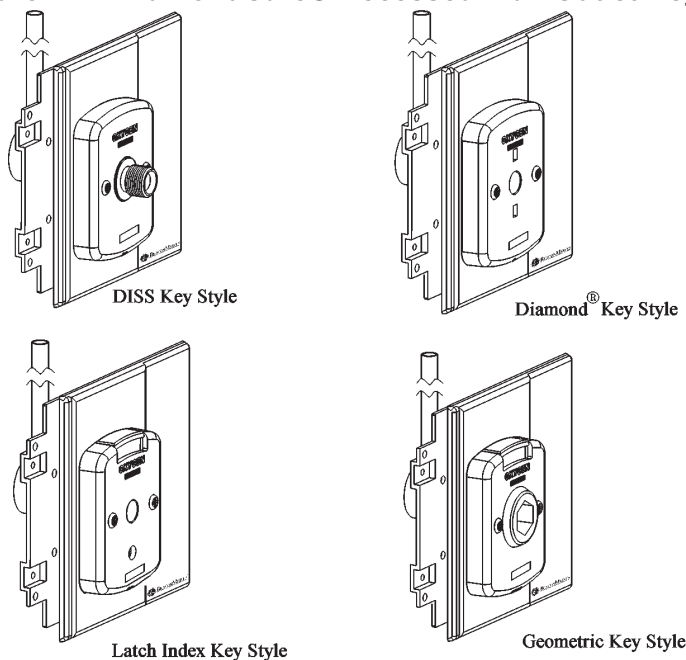

m245a026

## Key Style Identification

Key style identification dimples (A) are located on the face of the frontbody assembly at the bottom (see figure 1-3 on page 1–10). The pattern identifies the outlet key style. See table 1-2 on page 1-10 for DiamondCare® key style identification.

**Table 1-2. Key Style Identification**

Number of Dimples	Description
1	Diamond®
2	DISS
3	Latch Index Key®
4	Geometric Key

**Figure 1-3. Dimple Location**

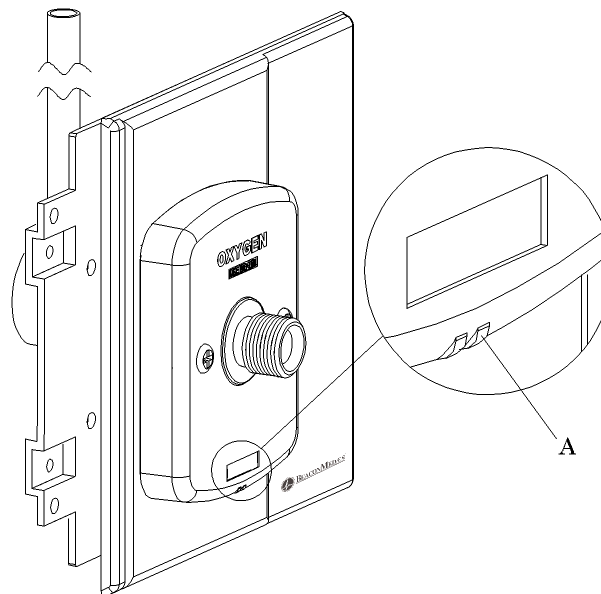

Other system features include the following:

- All wall outlets have a color-coded and labeled frontbody assembly to enable quick identification of all medical gases.
- Latch Index Key and Geometric Key key style frontbodies have an easy to access, downward-activated, adapter release button.
- Quick-Connect outlets incorporate a proprietary twist-lock barrel cartridge to permit quick replacement of the primary check valve without special tools (except Geometric Key key style Waste Anesthetic Gas Disposal (WAGD)).
- Rough-in assemblies include flush, interlocking flanges and a proprietary dual purpose, dust cover, purging insert.
- All outlets are cleaned for oxygen service, leak-tested, flow-tested, and capped prior to shipment.



---

## Assembly Identification

### Wall Outlet Rough-In Assemblies

Table 1-3 on page 1-11 identifies the DiamondCare® Recessed Wall Outlet rough-in assemblies.

**Table 1-3. Rough-In Assembly Identification**

<b>Gas Service</b>	<b>Rough-In Assembly</b>
O <sub>2</sub>	4107 2010 74
N <sub>2</sub> O	4107 2010 75
Vacuum	4107 2010 77
Air	4107 2010 76
CO <sub>2</sub>	4107 2010 80
N <sub>2</sub>	4107 2010 78
WAGD ♦	4107 2010 79
O <sub>2</sub> /CO <sub>2</sub>	4107 2010 81
♦ Waste Anesthetic Gas Disposal (formerly Evacuation)	

## Wall Outlet Finish Assemblies

Table 1-4 on page 1-12 identifies the DiamondCare® Recessed Wall Outlet finish assemblies.

**Table 1-4. Finish Assembly Identification**

Gas Service (disc/label color)	Wall Outlet Finish Assembly Key Style			
	Diamond®	DISS	Latch Index Key	Geometric Key
O <sub>2</sub> -green/white	4107 2010 94	4107 2011 08	4107 2011 02	4107 2010 86
N <sub>2</sub> O-blue/white	4107 2010 95	4107 2011 09	4107 2011 03	4107 2010 87
Vacuum-white/black	4107 2010 97	4107 2011 11	4107 2011 05	4107 2010 89
Air-yellow/black	4107 2010 96	4107 2011 10	4107 2011 04	4107 2010 88
CO <sub>2</sub> -grey/black	N/A	4107 2011 14	N/A	N/A
N <sub>2</sub> -black/white	N/A	4107 2011 12	N/A	N/A
WAGD♦-violet/white	4107 2010 98	4107 2011 13	4107 2011 06	4107 2010 09
O <sub>2</sub> /CO <sub>2</sub> -green/white	N/A	4107 2011 15	N/A	N/A
O <sub>2</sub> -ISO-white/green	4107 2010 99	4107 2011 16		4107 2010 91
Air-ISO-white/black	4107 2011 00	4107 2011 17		4107 2010 92
Vac-ISO- yellow/black	4107 2011 01	4107 2011 18		4107 2010 90
AGSS-ISO- violet/white	TBD	TBD	TBD	
♦ Waste Anesthetic Gas Disposal (formerly Evacuation)				

---

## Safety Tips

# 1



**WARNING:**

Only facility-authorized personnel should troubleshoot DiamondCare® Recessed Wall Outlets. Troubleshooting by unauthorized personnel could result in personal injury or equipment damage.



**WARNING:**

Only facility-authorized service personnel should service DiamondCare® Recessed Wall Outlets. Service performed by unauthorized personnel could result in personal injury or equipment damage.



**WARNING:**

Use only BeaconMedæ's service parts or assemblies for repairs and service procedures. Standard hardware and parts manufactured or supplied by other than BeaconMedæ's may cause the outlet to malfunction and void all warranty or responsibility by BeaconMedæ's.



**WARNING:**

Adhere to the "Infection Control Policies and Procedures" outlined in the Safety Coordinator Reference Guide. Failure to do so could result in the spread of infection.



**WARNING:**

Follow the product manufacturer's instructions. Failure to do so could result in personal injury or equipment damage.



**WARNING:**

Do not mix pressure (gas) and vacuum outlet components. Possible personal injury or equipment damage could occur.



**CAUTION:**

Notify all facility personnel whenever shutting off any medical gas supply. Failure to do so could result in patient injury or death.



**CAUTION:**

Before using an outlet after its installation, make sure that it has been connected to the correct gas/vacuum service. Test the piping system in accordance with applicable codes and standards. Failure to do so could result in death, personal injury or equipment damage.



**CAUTION:**

Shut off the gas/vacuum supply to the outlet before servicing the rough-in secondary check unit or seal bushing. Failure to do so could result in personal injury or equipment damage.



**CAUTION:**

Components of outlets for vacuum service must never be interchanged or used in outlets delivering pressurized gas service. Possibly injury or equipment damage could occur.



**CAUTION:**

Where DiamondCare® Recessed Wall Outlets are used in an air system supplied by a liquid ring air compressor that uses chlorinated water, and has galvanized piping or a galvanized air receiver, particular caution must be taken to frequently inspect and maintain of the air outlets. Chemical reactions occurring under those conditions may damage the pistons. Failure to maintain the air outlets could result in personal injury or equipment damaged.



**CAUTION:**

When testing an outlet for correct operation, do not allow the piston in the check valve to "snap" back into position. The shoulder on the piston can break, causing leakage.



**CAUTION:**

Do not over tighten a DISS adapter or connector to a DISS outlet. Possible equipment damage could occur.



**CAUTION:**

No repair should ever be undertaken or attempted by anyone not meeting the qualifications of or complying with the BeaconMedæ's repair policy and procedures. Failure to do so could result in equipment damage.



**CAUTION:**

Do not use harsh chemicals to clean the outlets. Possible damage could occur.



**CAUTION:**

Do not use oil or grease on or around the outlet. Doing so could result in equipment damage. Use only lubricants approved for oxygen service, such as Krytox® 6PL205.



**CAUTION:**

Do not use silicone-based lubricants. Equipment damage could occur.



**CAUTION:**

Only qualified service personal should use test equipment on the DiamondCare® Recessed Wall Outlets. Possible equipment damage could occur if test equipment is used improperly.

## Warning and Caution Labels

Figure 1-4. Warning and Caution Labels

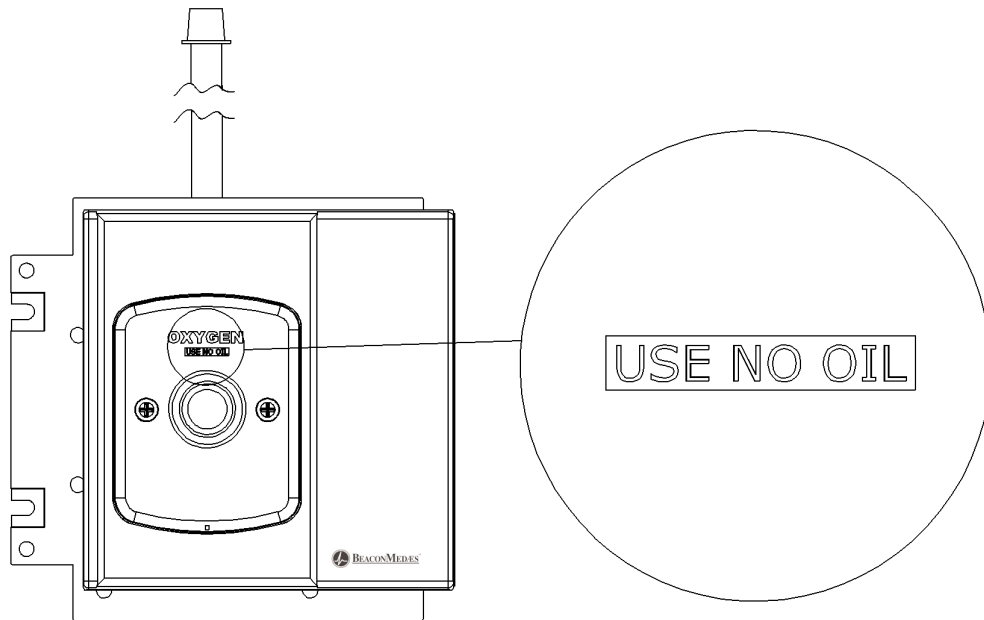

# Chapter 2 Troubleshooting Procedures

## Chapter Contents

Getting Started.....	2-2
Initial Actions .....	2-2
Function Checks .....	2-3
Final Actions.....	2-4
Test Equipment.....	2-4
DISS Key Style Medical Gas Wall Outlet Leakage.....	2-5
Diamond®, Latch Index, or Geometric Key Style Medical Gas Wall Outlet Leakage .....	2-5
Attachment Malfunction.....	2-6
Rough-In Assembly Leakage (Pressurized Medical Gases) .....	2-7
Rough-In Assembly Leakage (Vacuum Outlets Only).....	2-7

2

## Getting Started



### WARNING:

Only facility-authorized personnel should troubleshoot DiamondCare® Recessed Wall Outlets. Troubleshooting by unauthorized personnel could result in personal injury or equipment damage.

Begin each procedure in this chapter with step 1. Follow the sequence outlined (each step assumes the previous step has been completed). In each step, the normal operation of the product can be confirmed by answering Yes or No to the statement. Your response will lead to another step in the procedure, a repair analysis procedure (RAP), or a component replacement. If more than one component is listed, replace them in the given order.

To begin gathering information about the problem, start with **Initial Actions**.

Perform the **Function Checks** to isolate or identify a problem and to verify the repair after completing each corrective action (replacing or adjusting a part, seating a connector, etc.).

To verify the repair, perform the **Final Actions** after the **Function Checks**.

If troubleshooting procedures do not isolate the problem, call BeaconMedæx Technical Support at 1-(888) 4-MEDGAS (463-3427) for assistance.

---

### Initial Actions

To gather information from operators concerning problems with the DiamondCare® Recessed Wall Outlets, use Initial Actions. Note symptoms or other information concerning the problem that the operator describes. This information helps identify the probable cause.

1. Someone who can explain the problem is available.

**Yes**    **No**  
↓        → Go to “Function Checks” on page 2–3.

2. Ask that person to demonstrate or explain the problem. The problem can be duplicated.

**Yes**    **No**  
↓        → Go to “Function Checks” on page 2–3.

3. The problem is a result of improper operator action.

**Yes**    **No**  
↓        → Go to “Function Checks” on page 2–3.

4. To ensure proper operation of the DiamondCare® Recessed Wall Outlet, perform the “Function Checks” on page 2–3.

## Function Checks

1. Initial Actions have been performed.  
Yes ↓      No → Go to “Initial Actions” on page 2-2.
2. Attach a secondary piece of equipment to the DISS gas outlet. The gas outlet does not leak and is properly sealed.  
Yes ↓      No → Go to RAP 2.1.
3. Attach a secondary piece of equipment to the Diamond®, Latch Index, or Geometric quick connect key style gas outlet. The gas outlet does not leak and is properly sealed.  
Yes ↓      No → Go to RAP 2.2.
4. The gas outlet does not leak and is properly sealed when no secondary piece of equipment is attached.  
Yes ↓      No → For DISS gas outlets, go to RAP 2.1. For Diamond®, Latch Index, or Geometric quick connect key style gas outlets go to RAP 2.2.
5. Attach a secondary piece of equipment to the DISS, Diamond®, Latch Index, or Geometric key style gas outlet. The secondary piece of equipment locks into place and is properly attached to the gas outlet.  
Yes ↓      No → Go to RAP 2.3.
6. For pressurized medical gases, remove the finish assembly from the rough-in assembly. The rough-in assembly does not leak when the finish assembly is removed.  
Yes ↓      No → Go to RAP 2.4.
7. For vacuum outlets, ensure that the finish assembly is properly installed. The rough-in assembly does not leak, and is properly sealed when the finish assembly is installed.  
Yes ↓      No → Go to RAP 2.5.
8. Go to “Final Actions” on page 2–4.

## Final Actions

---

1. Complete the required service procedures. Refer to CGA Pamphlet E-10 (1999 Edition), *Maintenance of Medical Gas and Vacuum Systems in Health Care Facilities*.
  2. Complete all required administrative tasks.
- 

## Test Equipment



### CAUTION:

Only qualified service personal should use test equipment on the DiamondCare® Recessed Wall Outlets. Possible equipment damage could occur if test equipment is used improperly.

To complete the leakage test described, you will need fluid snoop in a bottle

This test equipment will help personnel pinpoint problems with the DiamondCare® Recessed Wall Outlets. This chapter includes a list of functions and the technical information required to inspect the outlet for problems.

## 2.1 DISS Key Style Medical Gas Wall Outlet Leakage

1. Attach a secondary piece of equipment to the DISS key style gas outlet. The gas outlet does not leak and is properly sealed.

**Yes**    **No**  
↓        → Replace the frontbody O-ring supplied in the DISS repair kit (refer to procedure 4.5). If this solves the problem, go to “Final Actions” on page 2–4. Otherwise, call BeaconMedæ’s Technical Support at 1-(888) 4-MEDGAS (463-3427).

2. Go to “Final Actions” on page 2–4.

## 2.2 Diamond®, Latch Index, or Geometric Key Style Medical Gas Wall Outlet Leakage

1. Attach a secondary piece of equipment onto the Diamond®, Latch Index, or Geometric key style gas outlet. The gas outlet does not leak and is properly sealed.

**Yes**    **No**  
↓        → Replace the frontbody O-ring supplied in the repair kit by referring to one of the following procedures:

- “Diamond® Quick-Connect Key Style Frontbody Assembly” on page 4–12
- “Latch Index Quick-Connect Key Style Frontbody Assembly” on page 4–15
- “Geometric Quick-Connect Key Style Frontbody Assembly” on page 4–17

If this solves the problem, go to “Final Actions” on page 2–4. Otherwise, go to step 2.

2. Replace the loaded barrel assembly (refer to procedure 4.2).

This solves the problem.

**Yes**    **No**  
↓        → Call BeaconMedæ’s Technical Support at 1-(888) 4-MEDGAS (463-3427).

3. Go to “Final Actions” on page 2–4.

### 2.3 Attachment Malfunction

1. Attach a secondary piece of equipment onto the DISS, Diamond®, Latch Index, or Geometric key style gas outlet. The secondary piece of equipment locks into place and is properly attached to the gas outlet.

**Yes**    **No**  
↓        → Ensure that the adapter on the secondary piece of equipment is the proper type and in good working order. If this solves the problem, go to “Final Actions” on page 2-4. Otherwise, go to step 2 for Diamond® key style, step 4 for Latch Index key style, or step 6 for Geometric key style.

2. For the Diamond® key style gas outlet, replace the adapter locking spring supplied in the frontbody repair kit (refer to procedure 4.6).

This solves the problem.

**Yes**    **No**  
↓        → Call BeaconMedæ’s Technical Support at 1-(888) 4-MEDGAS (463-3427).

3. Go to “Final Actions” on page 2-4.
4. For the Latch Index key style gas outlet, replace the frontbody assembly (refer to procedure 4.1).

This solves the problem.

**Yes**    **No**  
↓        → Call BeaconMedæ’s Technical Support at 1-(888) 4-MEDGAS (463-3427).

5. Go to “Final Actions” on page 2-4.
6. For the Geometric key style gas outlet, replace the frontbody assembly (refer to procedure 4.1).

This solves the problem.

**Yes**    **No**  
↓        → Call BeaconMedæ’s Technical Support at 1-(888) 4-MEDGAS (463-3427).

7. Go to “Final Actions” on page 2-4.

## 2.4 Rough-In Assembly Leakage (Pressurized Medical Gases)

1. Remove the finish assembly from the rough-in assembly on the gas outlet. The rough-in assembly seals properly and does not leak.

**Yes**    **No**  
↓        → Replace the rubber bushing for all gas outlet types (refer to procedure 4.3). If this solves the problem, go to “Final Actions” on page 2-4. Otherwise, call BeaconMedæ’s Technical Support at 1-(888) 4-MEDGAS (463-3427).

2. Go to “Final Actions” on page 2-4.

## 2.5 Rough-In Assembly Leakage (Vacuum Outlets Only)

1. Ensure the finish assembly is properly installed. The rough-in assembly does not leak, and is properly sealed when the finish assembly is installed.

**Yes**    **No**  
↓        → Replace the rubber bushing in the rough-in assembly (refer to procedure 4.4). If this solves the problem, go to “Final Actions” on page 2-5. Otherwise, call BeaconMedæ’s Technical Support at 1-(888) 4-MEDGAS (463-3427).

2. Go to “Final Actions” on page 2-4.

**NOTES:**

---

# ***Chapter 3***

## ***Theory of Operation***

### **Chapter Contents**

Theory of Operation .....	3-2
Hardware .....	3-2
Quick-Connect Key Style Outlets .....	3-2
DISS Key Style Outlets .....	3-2

**3**

## **Theory of Operation**

### **Hardware**

#### **Quick-Connect Key Style Outlets**

This section describes the theory of operation for a Quick-Connect Key Style Wall Outlet and identifies the corresponding parts.

**NOTE:**

In pressurized gas outlets, both the frontbody and rough-in assemblies contain primary and secondary check units. However, according to NFPA 99, medical vacuum inlets (which also include WAGD and AGSS) shall not contain secondary check units.

In the outlet rough-in assembly, a spring pushes the secondary check unit against a rubber bushing. This forms a gas-tight seal when a frontbody assembly is not attached to the rough-in assembly.

When a frontbody barrel is inserted into a rough-in assembly, the secondary check unit is forced open, which permits gas flow through the secondary check unit. A rubber bushing seals the barrel, preventing external leaks.

The primary check unit in the frontbody assembly prevents gas flow out of the outlet until an appropriate gas-specific adapter is fully inserted and engages the frontbody assembly.

When an adapter is inserted into the frontbody keying disc, the adapter nose pushes the frontbody piston back. This breaks the seal between the frontbody barrel and the frontbody O-ring, which allows gas to flow. A locking spring or latching plate holds the adapter in place.

The frontbody O-ring forms a gas-tight seal around the nose of the adapter, allowing gas to pass through the adapter without leaking.

#### **DISS Key Style Outlets**

This section describes the theory of operation for a DISS Key Style Wall Outlet and identifies the corresponding parts.

**NOTE:**

In pressurized gas outlets both the frontbody and rough-in assemblies contain check units, primary and secondary check units respectively. However, according to NFPA 99, medical vacuum inlets (which also include WAGD and AGSS) shall not contain secondary check units.

In the outlet rough-in assembly, a spring pushes the secondary check unit against a rubber bushing. This forms a gas-tight seal when a frontbody assembly is not attached to the rough-in assembly.

When a frontbody barrel is inserted into a rough-in assembly, the secondary check unit is forced open, which permits gas flow through the secondary check unit. A rubber bushing seals the barrel, preventing external leaks.

The primary check unit in the frontbody assembly prevents gas flow out of the outlet until an appropriate gas-specific adapter is fully inserted and engaged in the frontbody assembly.

When a DISS (female) adapter is connected onto the frontbody threaded DISS (male) barrel, the nose of the DISS adapter pushes the frontbody piston back. This breaks the seal between the frontbody barrel and the frontbody O-ring, which allows gas to flow.

**NOTES:**

---

# Chapter 4 Removal, Replacement, and Adjustment Procedures

## Chapter Contents

Frontbody Assembly.....	4-3
Removal.....	4-3
Replacement .....	4-3
Twist-Lock Replaceable Barrel Assembly .....	4-4
Removal.....	4-4
Replacement .....	4-4
Rough-In Secondary Check Unit Assembly (Pressurized Outlets Only) .....	4-6
Removal.....	4-6
Replacement .....	4-7
Rough-In Assembly (Vacuum Outlets Only) .....	4-8
Removal.....	4-8
Replacement .....	4-8
DISS Key Style Frontbody Assembly .....	4-10
Removal.....	4-10
Replacement .....	4-11
Diamond® Quick-Connect Key Style Frontbody Assembly .....	4-12
Removal.....	4-12
Replacement .....	4-13
Latch Index Quick-Connect Key Style Frontbody Assembly.....	4-15
Removal.....	4-15
Replacement .....	4-16
Geometric Quick-Connect Key Style Frontbody Assembly .....	4-17

# 4

Removal.....4-17

Replacement .....4-18

## 4.1 Frontbody Assembly

Tools required: #2 phillips head screwdriver

### Removal

You do not have to turn off an outlet's gas service supply before removing and servicing the frontbody assembly for pressure gas services. The secondary check valve and bushing in the rough-in assembly prevents gas flow from the gas service supply line. (Since medical vacuum, WAGD, and AGSS do not have secondary checks, temporarily turn off the outlet's vacuum supply or install the pressure test cap.)

1. Using a #2 phillips head screwdriver, loosen the two screws (A) that secure the frontbody assembly (B) and the finish faceplate (C) to the rough-in assembly (D) (see figure 4-1 on page 4-3).

**Figure 4-1. Frontbody Assembly Removal**

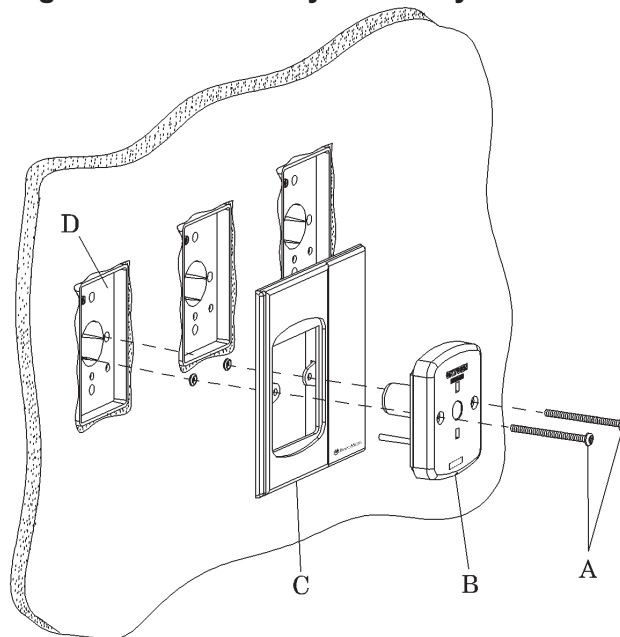

2. Carefully remove the frontbody assembly (B) and the finish faceplate (C) from the rough-in assembly.

### Replacement

1. Inspect the parts of the frontbody assembly for excessive wear or damage.
2. Replace defective parts as necessary.
3. To install the replacement frontbody assembly, reverse the removal procedure.
4. To ensure proper operation of the frontbody assembly, perform the "Function Checks" on page 2-3.

## 4.2 Twist-Lock Replaceable Barrel Assembly

Tools required: None

Parts required: Refer to “Replacement Twist-Lock Barrel Assembly Repair Kits” on page 5–31 to select the proper twist-lock replaceable barrel assembly.

### Removal



#### WARNING:

Notify all facility personnel whenever shutting off any medical gas supply. Failure to do so could result in patient injury or death.

#### NOTE:

You do not have to turn off an outlet’s gas service supply before removing and servicing the twist-lock replaceable barrel assembly for pressure gas services. The secondary check valve and bushing in the rough-in assembly prevent gas flow from the gas service supply line. (Since medical vacuum, WAGD, and AGSS do not have secondary checks, temporarily turn off the outlet’s gas service supply, or install the pressure test cap.)

1. Remove the frontbody assembly (refer to procedure 4.1).
2. Rotate the twist-lock barrel assembly (A) counterclockwise 180° until the flat portion of the barrel assembly is moved from the 6:00 position (**locked**) to the 12:00 position (**unlocked**) (see figure 4-2 on page 4–5).

#### NOTE:

Be careful not to lose the O-ring and washer when removing the twist-lock replaceable barrel assembly from the keying disc assembly.

3. Tilt the twist-lock replaceable barrel assembly (A) downward, and remove it from the keying disc assembly (B), being careful not to lose the small O-ring (C) and washer (D).

### Replacement

1. Inspect the parts of the frontbody assembly for excessive wear or damage.
2. Replace defective parts as necessary.
3. To install a twist-lock replaceable barrel assembly (A), reverse the removal procedure.

Figure 4-2. Frontbody Barrel Assembly

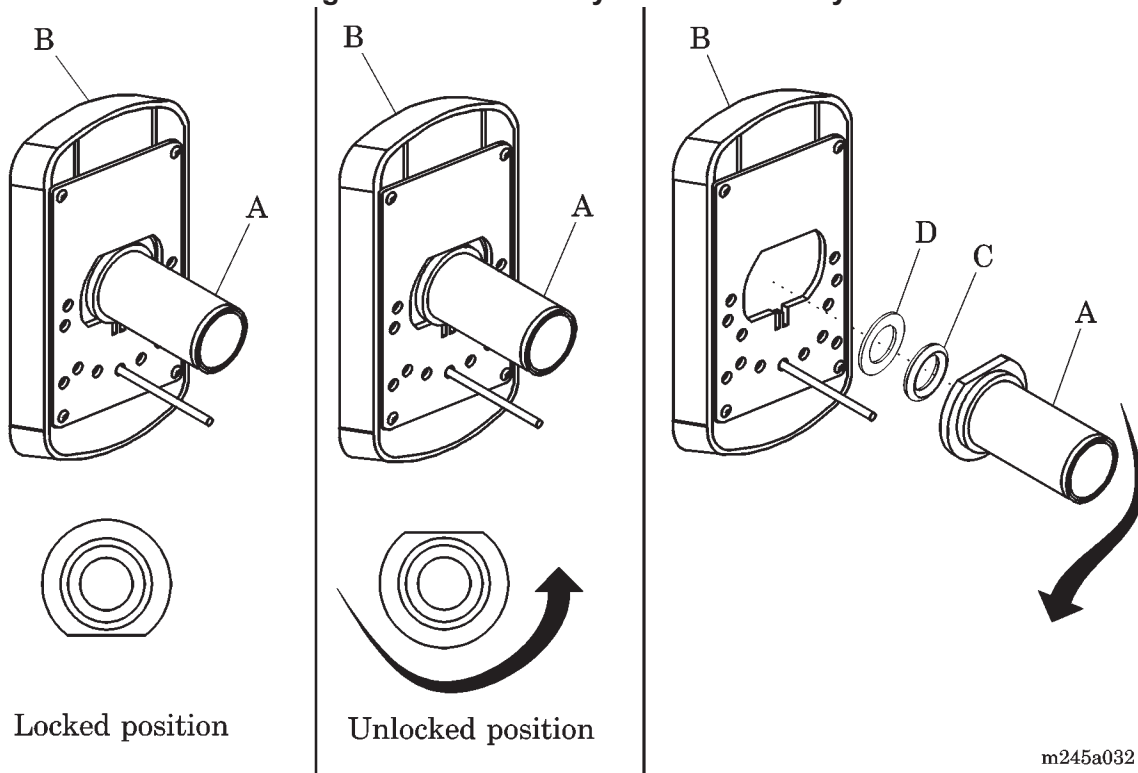

4. Ensure that the O-ring (C) and washer (D) are in place on the frontbody assembly before installing the twist-lock replaceable barrel assembly.

**NOTE:**

Once the twist-lock replaceable barrel assembly is installed, the flat portion of the barrel assembly should be located in the bottom, 6:00 position.

5. Lock the barrel assembly by twisting it back to its original 6:00 position.
6. To ensure proper operation of the twist-lock replaceable barrel assembly, perform the “Function Checks” on page 2–3.

### 4.3 Rough-In Secondary Check Unit Assembly (Pressurized Outlets Only)

Tools required: Small screwdriver

#### Removal



**WARNING:**

Notify all facility personnel whenever shutting off any medical gas supply. Failure to do so could result in patient injury or death.



**WARNING:**

Shut off the gas supply to the outlet before servicing the rough-in secondary check unit assembly. Failure to do so could result in personal injury or equipment damage.

1. Shut off the gas supply to the outlet.
2. Remove the finish/frontbody assembly (refer to procedure 4.1).
3. Note the removal sequence of the internal parts in the rough-in secondary check unit assembly to ensure proper replacement during the installation procedure.
4. Using a small screwdriver, remove the retaining ring (A) from the rough-in assembly (B) (see figure 4-3 on page 4–7).
5. Remove the washer (C).
6. Using the small screwdriver, carefully remove the rubber bushing (D) from the rough-in assembly (B).
7. Remove the secondary check (E).
8. Remove the spring (F).

**Figure 4-3. Rough-In Secondary Check Unit Assembly (Pressure Gas)**

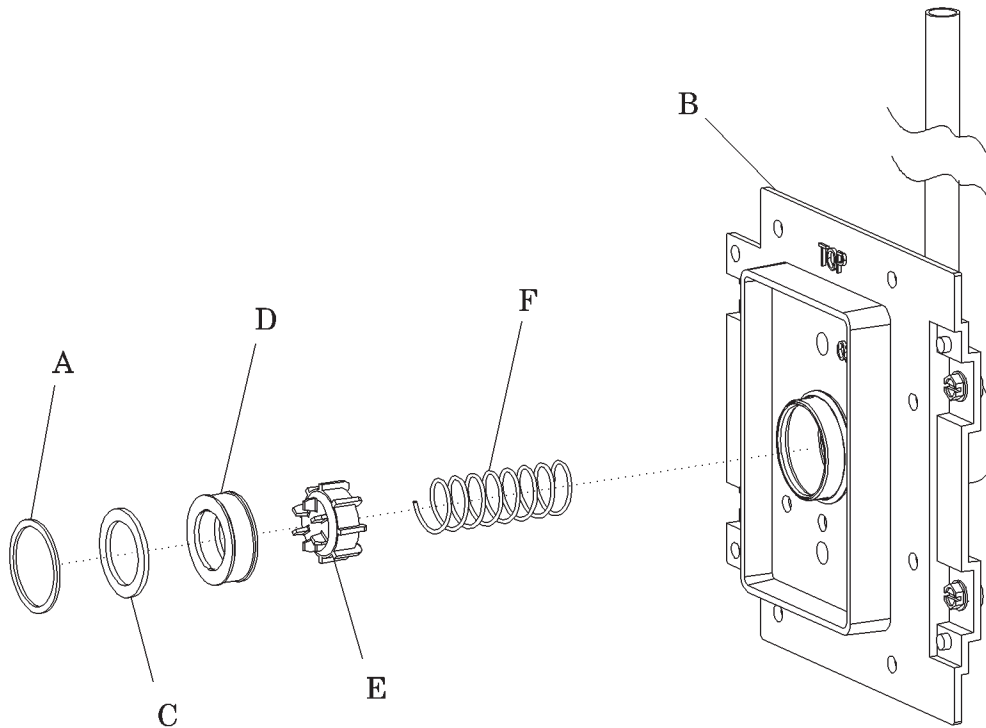

## Replacement

1. Replace all the parts included in the replacement kit.
2. To install the replacement secondary check unit assembly, reverse the removal procedure.
3. To ensure proper operation of the rough-in secondary check unit assembly, perform the “Function Checks” on page 2–3.

## 4.4 Rough-In Assembly (Vacuum Outlets Only)

Tools required: Small screwdriver

### Removal



**WARNING:**

Notify all facility personnel whenever shutting off any medical gas supply. Failure to do so could result in patient injury or death.



**WARNING:**

Shut off the service supply to the outlet before servicing the vacuum outlet bushing. Failure to do so could result in personal injury or equipment damage.

1. Shut off the service supply to the outlet.
2. Remove the frontbody assembly (refer to procedure 4.1).
3. Note the removal sequence of the internal parts in the rough-in assembly to ensure proper replacement during the installation procedure.
4. Using a small screwdriver, remove the retaining ring (A) from the rough-in assembly (B) (see figure 4-4 on page 4-9).
5. Remove the washer (C).
6. Using the small screwdriver, carefully remove the rubber bushing (D) from the rough-in assembly (B).

### Replacement

1. Replace all the parts included in the replacement kit.
2. To install the replacement rough-in assembly, reverse the removal procedure.
3. To ensure proper operation of the rough-in assembly, perform the “Function Checks” on page 2-3.

Figure 4-4. Rough-In Assembly (Vacuum Only)

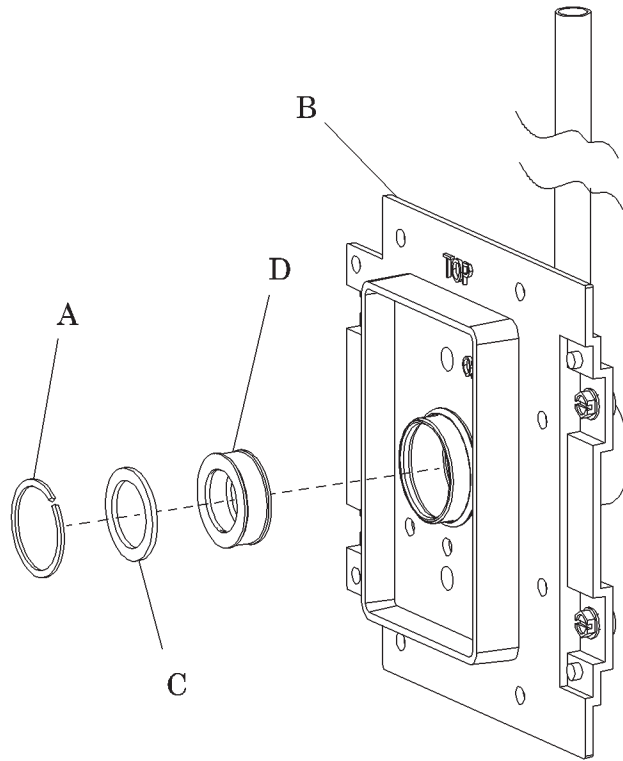

## 4.5 DISS Key Style Frontbody Assembly

Tools required: Retaining ring removal/installation tool (appropriate size/type)  
Small screwdriver

### Removal



#### WARNING:

Notify all facility personnel whenever shutting off any medical gas supply. Failure to do so could result in patient injury or death.

#### NOTE:

You do not have to turn off the outlet's gas service supply before removing and servicing the DISS key style frontbody assembly for pressure gas services. The secondary check valve and bushing in the rough-in assembly prevents gas flow from the pressure gas service supply line except in vacuum outlets.

#### NOTE:

Medical vacuum, WAGD, and AGSS do not have secondary checks. The service supply must be turned off, or the pressure test cap should be installed in order to service their rough-in assemblies. Otherwise, the line will continue to maintain a draw (suction).

1. Remove the frontbody assembly (refer to procedure 4.1).
2. Note the removal sequence of the internal parts of the DISS key style frontbody assembly to ensure proper replacement during the installation procedure.
3. Using the retaining ring removal/installation tool or a small screwdriver, remove the retaining ring (A) from the rear of the DISS frontbody assembly (B) (see figure 4-5 on page 4-11).
4. Remove all of the internal parts from the DISS frontbody assembly (B) by performing the following:
  - a. Carefully remove the DISS frontbody spring (C).
  - b. Remove the DISS piston (D).
  - c. Remove the frontbody piston O-ring (E) from the DISS piston (D).

**Figure 4-5. DISS Key Style Frontbody Assembly**

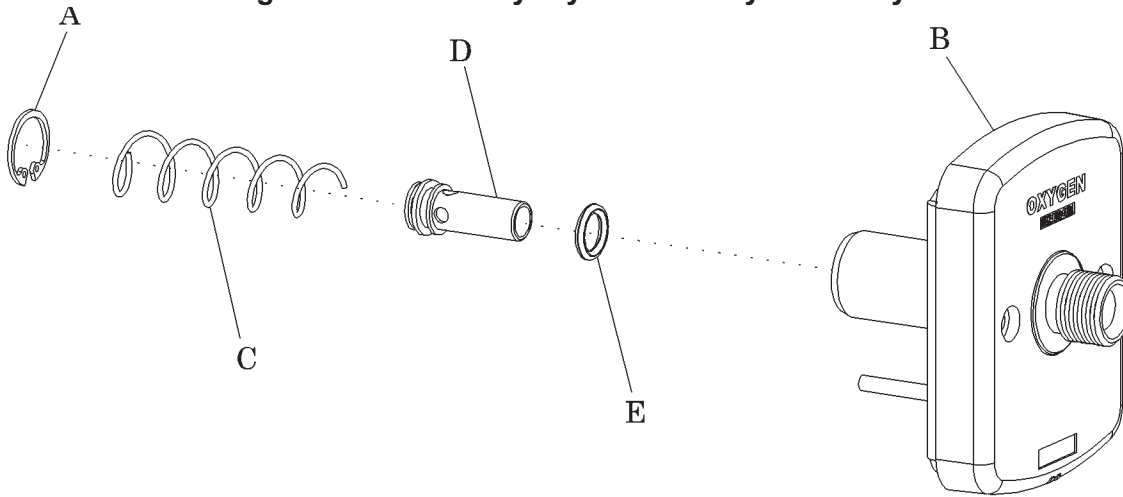

## Replacement

1. Inspect the parts of the frontbody assembly for excessive wear or damage.
2. Replace defective parts as necessary.
3. To install the replacement DISS frontbody assembly, reverse the removal procedure.
4. To ensure proper operation of the DISS key style frontbody assembly, perform the “Function Checks” on page 2–3.

## 4.6 Diamond® Quick-Connect Key Style Frontbody Assembly

Tools required: Retaining ring removal/installation tool (appropriate size/type)  
Needle nose pliers

The procedure in this section describes how to replace the components of the twist-lock barrel assembly.

### Removal

**NOTE:**

You do not have to turn off the outlet's gas service supply before removing and servicing the Diamond® Quick-Connect key style frontbody assembly for pressure gas services. The secondary check valve and bushing in the rough-in assembly prevents gas flow from the pressure gas service supply line.

**NOTE:**

Medical vacuum, WAGD, and AGSS do not have secondary checks. The service supply must be turned off, or the pressure test cap should be installed in order to service their rough-in assemblies. Otherwise, the line will continue to maintain a draw (suction).

1. Remove the twist-lock replaceable barrel assembly (refer to procedure 4.2).
2. Note the removal sequence of the internal parts in the Diamond® Quick-Connect frontbody assembly to ensure proper replacement during the installation procedure.
3. Using the retaining ring removal tool or a small screwdriver, remove the retaining ring (A) from the rear of the twist-lock replaceable barrel assembly (B) (see figure 4-6 on page 4-12).

**Figure 4-6. Diamond® Quick-Connect Key Style Frontbody Assembly**

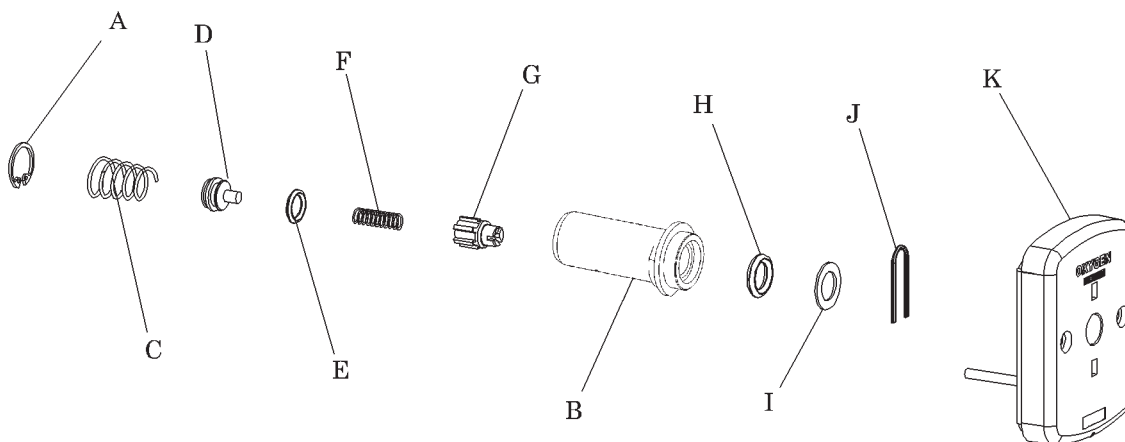

4. Remove all of the internal parts from the twist-lock replaceable barrel assembly (B) by performing the following:
  - a. Carefully remove the frontbody secondary piston spring (C).
  - b. Remove the secondary piston (D).
  - c. Remove the frontbody piston O-ring (E) from the secondary piston (D).
  - d. Remove the spring (F).
  - e. Remove the frontbody piston (G).
5. Remove the parts located at the front of the twist-lock replaceable barrel assembly (B) by performing the following:
  - a. Remove the O-ring (H) from the front of the twist-lock replaceable barrel assembly (B).

**NOTE:**

The adapter locking spring clip in the frontbody keying disc assembly can be accessed through the opening from which the twist-lock replaceable barrel assembly was removed.

- b. Remove the frontbody washer (I) from the frontbody keying disc assembly (K).
- c. Using the needle nose pliers, remove the adapter locking spring clip (J) from the keying disc assembly (K).

**Replacement**

1. Inspect the parts of the frontbody assembly for excessive wear or damage.
2. Replace defective parts as necessary.
3. To install the replacement Diamond® Quick-Connect frontbody assembly, reverse the removal procedure.
4. During the replacement procedure, ensure that the frontbody secondary piston spring (A) is seated properly onto the secondary piston (B) groove (see figure 4-7 on page 4-14).



## 4.7 Latch Index Quick-Connect Key Style Frontbody Assembly

Tools required: Retaining ring removal/installation tool (appropriate size/type)

The procedure in this section describes how to replace the components of the twist-lock barrel assembly.

### Removal

#### NOTE:

You do not have to turn off an outlet's gas service supply before removing and servicing the Latch Index Quick-Connect key style frontbody assembly for pressure gas services. The secondary check valve and bushing in the rough-in assembly prevent gas flow from the gas service supply line. (Since medical vacuum, WAGD, and AGSS do not have secondary checks, temporarily turn off the outlet's gas service supply or install the pressure test cap.)

1. Remove the twist-lock replaceable barrel assembly (refer to procedure 4.2).
2. Note the removal sequence of the internal parts in the Latch Index Quick-Connect key style frontbody assembly to ensure proper replacement during the installation procedure.
3. Using the retaining ring removal tool, remove the retaining ring (A) from the rear of the twist-lock replaceable barrel assembly (B) (see figure 4-8 on page 4-15).

**Figure 4-8. Latch Index® Quick-Connect Key Style Frontbody Assembly**

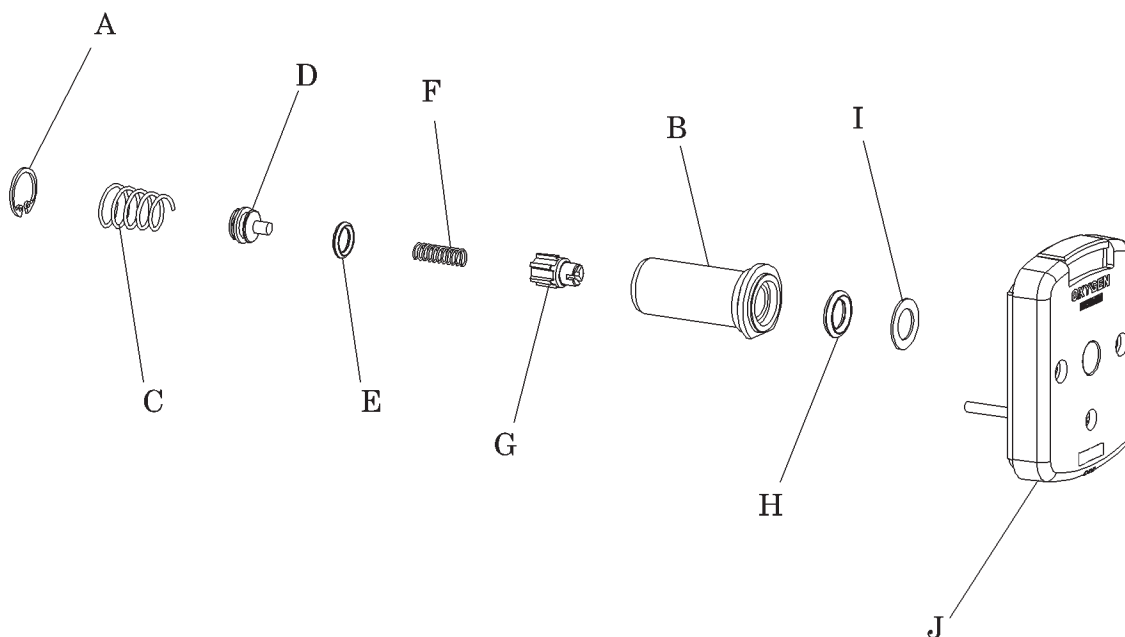

4. Remove all of the internal parts from the twist-lock replaceable barrel assembly (B) by performing the following:
  - a. Carefully remove the frontbody secondary piston spring (C).
  - b. Remove the secondary piston (D).
  - c. Remove the frontbody piston O-ring (E) from the secondary piston (D).
  - d. Remove the spring (F).
  - e. Remove the frontbody piston (G).
  - f. Remove the O-ring (H) from the front of the twist-lock replaceable barrel assembly (B).
  - g. Remove the frontbody washer (I) from the frontbody keying disc assembly (J).

## **Replacement**

1. Inspect the parts of the frontbody assembly for excessive wear or damage.
2. Replace defective parts as necessary.
3. To install the replacement Latch Index Quick-Connect key style frontbody assembly, reverse the removal procedure.
4. To ensure proper operation of the Latch Index Quick-Connect key style frontbody assembly, perform the “Function Checks” on page 2–3.

## 4.8 Geometric Quick-Connect Key Style Frontbody Assembly

Tools required: Retaining ring removal/installation tool (appropriate size/type)

The procedure in this section describes how to replace the components of the twist-lock barrel assembly.

### Removal

**NOTE:**

You do not have to turn off the outlet's gas service supply before removing and servicing the Geometric Quick-Connect key style frontbody assembly for pressure gas services. The secondary check valve and bushing in the rough-in assembly prevents gas flow from the pressure gas service supply line.

**NOTE:**

Medical vacuum, WAGD, and AGSS do not have secondary checks. The service supply must be turned off, or the pressure test cap should be installed in order to service their rough-in assemblies. Otherwise, the line will continue to maintain a draw (suction).

1. Remove the twist-lock replaceable barrel assembly (refer to procedure 4.2).
2. Note the removal sequence of the internal parts in the Geometric Quick-Connect key style frontbody assembly to ensure proper replacement during the installation procedure.
3. Using the retaining ring removal tool, remove the retaining ring (A) from the rear of the twist-lock replaceable barrel assembly (B) (see figure 4-9 on page 4-18).

**Figure 4-9. Geometric Quick-connect Key Style Frontbody Assembly**

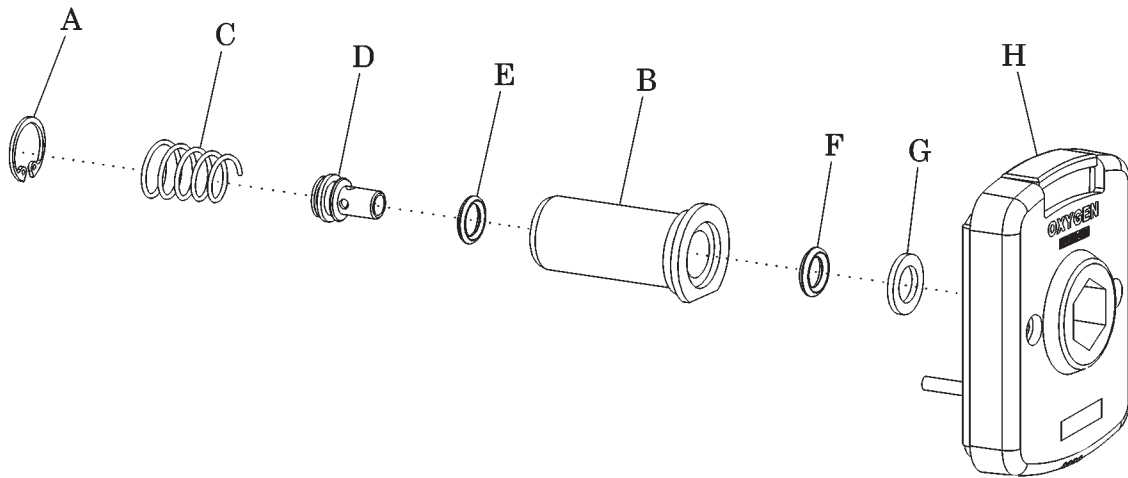

m245a011

**NOTE:**

For Waste Anesthetic Gas Disposal (WAGD), and AGSS service only, the barrel assembly is permanently attached to the frontbody keying disc assembly.

4. Remove all of the internal parts from the twist-lock replaceable barrel assembly (B) by performing the following:
  - a. Carefully remove the frontbody piston spring (C).
  - b. Remove the frontbody piston (D).
  - c. Remove the frontbody piston O-ring (E) from the frontbody piston (D).
  - d. Remove the O-ring (F) and washer (G).

**Replacement**

1. Inspect the parts of the frontbody assembly for excessive wear or damage.
2. Replace defective parts as necessary.
3. To install the replacement Geometric Quick-Connect key style frontbody assembly, reverse the removal procedure.
4. To ensure proper operation of the Geometric Quick-Connect key style frontbody assembly, perform the “Function Checks” on page 2–3.

# Chapter 5

## Parts List

### Chapter Contents

Warranty .....	5-3
Service Parts Ordering.....	5-5
Recommended Spare Parts .....	5-5
DISS Key Style Finish Assembly.....	5-6
Diamond® Quick-Connect Key Style Finish Assembly.....	5-8
Latch Index Quick-Connect Key Style Finish Assembly .....	5-10
Geometric Quick-Connect Key Style Finish Assembly .....	5-12
Gas Service Rough-In Assembly.....	5-14
Twist-Lock Finish Assembly .....	5-16
Power Drop Straight Blade Finish Assembly.....	5-17
Duplex Receptacle Finish Assembly .....	5-18
Outlet—GFCI Finish Assembly .....	5-19
Toggle Switch Finish Assembly .....	5-20
Decora® Switch Finish Assembly .....	5-21
Low Voltage Switch Finish Assembly .....	5-22
Blank Provision Finish Assembly .....	5-23
Electrical Accessories Rough-In Assembly.....	5-24
Recessed Wall Slide Finish Assembly.....	5-25
Recessed Wall Blank Finish Assembly .....	5-26
Recessed Wall Slide Rough-In Assembly .....	5-27
Wall-Mounted Slide Finish Assembly with Anchors .....	5-28

Surface-Mounted Gas Outlet Enclosure.....	5-29
Surface-Mounted Slide Enclosure.....	5-30
Replacement Twist-Lock Barrel Assembly Repair Kits .....	5-31
Frontbody Repair Parts Kits.....	5-32
Rough-In Assembly Repair Parts Kits .....	5-33
DiamondCare® Conversion Kits .....	5-34

---

## Warranty

BeaconMedæs warrants the DiamondCare® Recessed Wall Outlets and Electrical Accessories to be free of defects in materials or workmanship when installed and operated in accordance with instructions. The warranty period is 30 months from shipment date or 24 months from startup, whichever period terminates earlier.

This warranty covers all necessary parts and labor required for correction of the defect whether by any or all of repair, replacement, or credit, which election shall be made by BeaconMedæs at its sole discretion.

This warranty requires the owner to ensure that the equipment is 1) started up or placed in service by an authorized representative of BeaconMedæs, 2) certified in accordance with NFPA 99, most recent edition, by a properly qualified certification agency, and 3) maintained in strict accordance with Operation and Maintenance Instructions provided with the product.

Warranty claims will be honored only after examination by BeaconMedæs and only when such examination shall disclose to BeaconMedæs's reasonable satisfaction that such equipment has not been damaged in shipment or

installation, improperly installed, operated outside of any published operating limits (including but not limited to temperature, pressure, humidity, or ventilation), improperly or inadequately maintained, field modified in any way, improperly repaired, or in any other way improperly applied or used.

All claims against this warranty require prompt notification, within the warranty period, of any seeming defect. Failure to promptly notify BeaconMedæs of the seeming defect will invalidate all warranties.

This warranty excludes damage or defect caused by shipping, acts of God, fire, war, labor difficulties, action of government, or other cause beyond the reasonable control of BeaconMedæs.

This warranty is given in lieu of all other warranties, expressed or implied, including implied warranties of fitness for a particular purpose and merchantability. In no event shall BeaconMedæs be liable for damages in excess of the value of the defective product, nor shall BeaconMedæs be liable for any direct, special or consequential damages, loss of profit of any kind, or for loss of use of the products.

**NOTES:**

---

---

## Service Parts Ordering

Use the part numbers listed in this section of the manual to identify service parts to be ordered. To order parts, call BeaconMedæx at (888) 4-MEDGAS (888-463-3427).

---

## Recommended Spare Parts

For a recommended spare parts list for the DiamondCare® series of Medical Gas Recessed Wall Outlets, see table 5-1 on page 5-5.

**Table 5-1. Recommended Spare Parts List**

<b>Quantity</b>	<b>Description</b>
1 per 10 outlets per key style	Twist-lock barrel assembly
1 per 25 outlets	Frontbody keying disc assembly
3 per 100 outlets	Rough-in repair kits (pressurized or vacuum)
3 per 100 outlets	Finish repair kits
1 per 20 outlets	Faceplate, outlet, powder coated
1 per 25 outlets	Complete finish assembly

## DISS Key Style Finish Assembly

Figure 5-1. DISS Key Style Finish Assembly

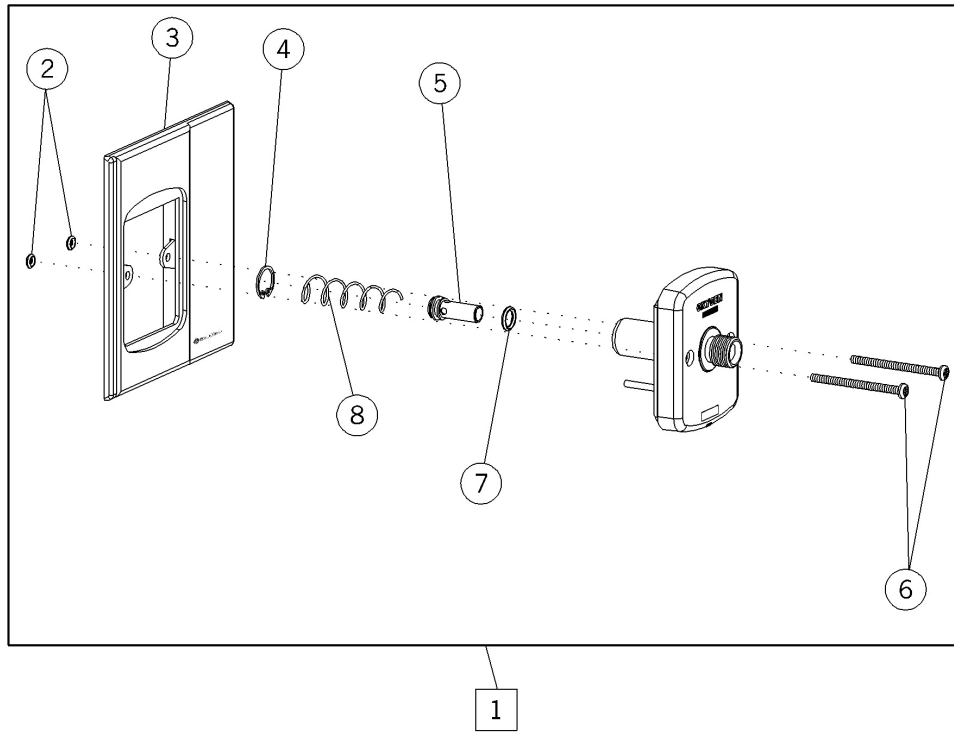

**Table 5-2. DISS Key Style Finish Assembly**

	<b>Part Number</b>	<b>Quantity</b>	<b>Description</b>
1	4107 2011 08	1	O <sub>2</sub> finish assembly—green/white
	4107 2011 09		N <sub>2</sub> O finish assembly—blue/white
	4107 2011 11		VAC finish assembly—white/black
	4107 2011 10		Air finish assembly—yellow/black
	4107 2011 14		CO <sub>2</sub> finish assembly—grey/black
	4107 2011 12		N <sub>2</sub> finish assembly—black/white
	4107 2011 13		WAGD finish assembly—violet/white
	4107 2011 15		O <sub>2</sub> /CO <sub>2</sub> finish assembly—green/white
	4107 2011 16		O <sub>2</sub> -ISO finish assembly—white/green
	4107 2011 17		Air-ISO finish assembly—white/black
	4107 2011 18		Vac-ISO finish assembly—yellow/black
	AGSS-ISO finish assembly—violet/white		
2	4107 6520 21	2	O-ring, screw retainer
3	4107 2011 78	1	Faceplate, gas outlet, powder coated
4	4107 6523 24 ♦	1	Retaining ring
5	4107 6521 80 or 4107 6521 79	1	Piston—for O <sub>2</sub> , VAC, EVAC or Piston—DISS
6	4107 6523 21	2	Screw—pan PH SST 6-32 x 1-7/8
7	4107 6520 28 ♦	1	O-ring
8	4107 6523 25	1	Spring, piston DISS

- ♦ Included within the frontbody repair kit. See table 5-23 on page 5-32 for details.

## Diamond® Quick-Connect Key Style Finish Assembly

Figure 5-2. Diamond® Quick-Connect Key Style Finish Assembly

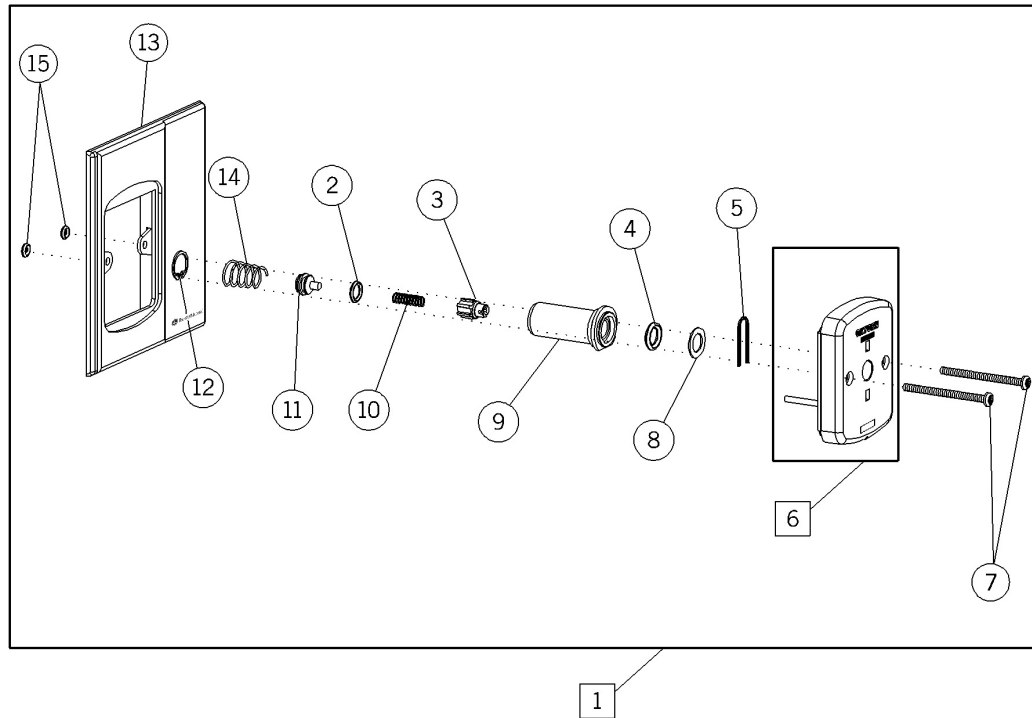

Table 5-3. Diamond® Quick-Connect Key Style Finish Assembly

	Part Number	Quantity	Description
1	6803-8121-800	1	O <sub>2</sub> finish assembly—green/white
	or		N <sub>2</sub> O finish assembly—blue/white
	6803-8121-801		VAC finish assembly—white/black
	or		Air finish assembly—yellow/black
	6803-8121-802		WAGD finish assembly—violet/white
	or		O <sub>2</sub> -ISO finish assembly—white/green
	6803-8121-803		Air-ISO finish assembly—white/black
	or		Vac-ISO finish assembly—yellow/black
	6803-8121-806		AGSS-ISO finish assembly—violet/white
	or		
2	0210-0601-300◆+	1	O-Ring—frontbody piston

Item Number	Part Number	Quantity	Description
3	6803-2000-200◆+	1	Piston—Diamond® frontbody
4	0210-0664-300◆+	1	O-Ring—Diamond® frontbody
5	0203-5069-300◆+	1	Spring Clip—Diamond® frontbody
6	6803-8111-900 or 6803-8111-901 or 6803-8111-902 or 6803-8111-903 or 6803-8111-904 or 6803-8111-906 or 6803-8111-908 or 6803-8111-909 or 6803-8111-910 or 6803-8111-911	1	Frontbody keying disc assembly—O <sub>2</sub> Frontbody keying disc assembly—N <sub>2</sub> O Frontbody keying disc assembly—VAC Frontbody keying disc assembly—Air outlet Frontbody keying disc assembly—CO <sub>2</sub> Frontbody keying disc assembly—WAGD Frontbody keying disc assembly—O <sub>2</sub> -ISO Frontbody keying disc assembly—Air-ISO Frontbody keying disc assembly—Vac-ISO Frontbody keying disc assembly—AGSS
7	6812-2001-003	2	Screw—pan PH SST 6-32 x 1-7/8
8	0402-1130-300◆+	1	Washer—Diamond® frontbody
9	6803-2000-178+	1	Barrel—Diamond® frontbody
10	6812-2000-995◆+	1	Spring
11	6803-2000-174+	1	Secondary Piston—Diamond® frontbody
12	6812-2001-007◆+	1	Retaining ring, outlet barrel
13	6803-2000-205	1	Faceplate, gas outlet, powder coated
14	6812-2001-009◆+	1	Spring—frontbody secondary piston
15	0210-0559-300	2	O-ring, screw retainer

◆ Included within the frontbody repair kit. See table 5-23 on page 5-32 for details.

+ Included within the replacement twist-lock barrel assembly. See table 5-22 on page 5-31 for details.



## Latch Index Quick-Connect Key Style Finish Assembly

Figure 5-3. Latch Index Quick-Connect Key Style Finish Assembly

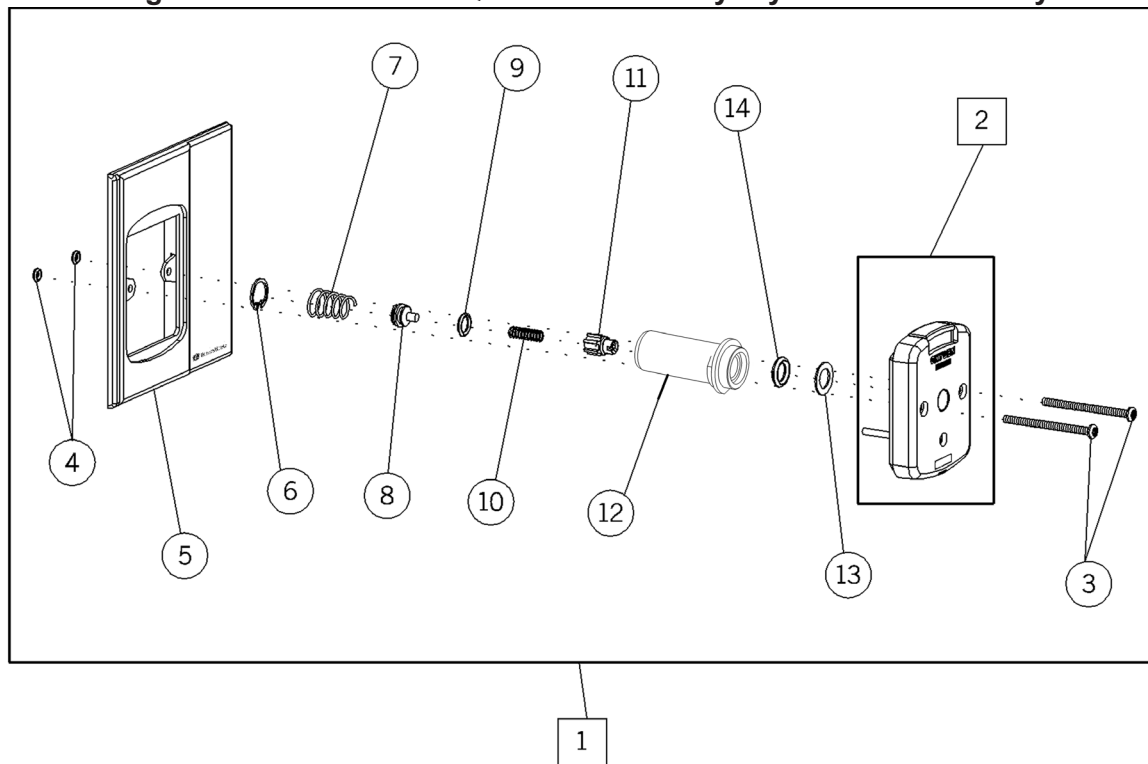

Table 5-4. Latch Index Quick-Connect Key Style Finish Assembly

Item Number	Part Number	Quantity	Description
1	6803-8123-800	1	O <sub>2</sub> finish assembly—green/white
	or		N <sub>2</sub> O finish assembly—blue/white
	6803-8123-801		
	or		VAC finish assembly—white/black
	6803-8123-802		
	or		Air finish assembly—yellow/black
	6803-8123-803		
	or		WAGD finish assembly—violet/white
	6803-8123-806		
	or		O <sub>2</sub> -ISO finish assembly—white/green
	6803-8123-808		
or	Air-ISO finish assembly—white/black		
6803-8123-809			
or	Vac-ISO finish assembly—yellow/black		
6803-8123-810			
or	AGSS-ISO finish assembly—violet/white		
6803-8123-811			

Item Number	Part Number	Quantity	Description
2	6803-8114-900 or 6803-8114-901 or 6803-8114-902 or 6803-8114-903 or 6803-8114-906 or 6803-8114-908 or 6803-8114-909 or 6803-8114-910 or 6803-8114-911	1	Frontbody keying disc assembly—O <sub>2</sub>  Frontbody keying disc assembly—N <sub>2</sub> O  Frontbody keying disc assembly—VAC  Frontbody keying disc assembly—Air outlet  Frontbody keying disc assembly—WAGD  Frontbody keying disc assembly—O <sub>2</sub> -ISO  Frontbody keying disc assembly—Air-ISO  Frontbody keying disc assembly—Vac-ISO  Frontbody keying disc assembly—AGSS
3	6812-2001-003	2	Screw—pan PH SST 6-32 x 1-7/8
4	0210-0559-300	2	O-ring, screw retainer
5	6803-2000-205	1	Faceplate, outlet, powder coated
6	6812-2001-007◆+	1	Retaining ring, outlet barrel
7	6812-2001-009◆+	1	Spring—frontbody secondary piston
8	6803-2000-174+◆◆	1	Secondary piston—Diamond® frontbody
9	0210-0601-300◆+	1	O-ring—frontbody piston
10	6812-2000-995◆+	1	Spring
11	6803-2000-200◆+◆◆	1	Piston—Diamond® frontbody
12	525229-00+◆◆	1	Barrel—Diamond® frontbody
13	0402-1130-300◆+	1	Washer—Diamond® frontbody
14	0210-0664-300◆+	1	O-ring—Diamond® frontbody

- ◆ Included within the frontbody repair kit. See table 5-23 on page 5-32 for details.
- + Included within the replacement twist-lock barrel assembly. See table 5-22 on page 5-31 for details.
- ◆◆ Used in both Diamond® and Latch Index key style frontbody barrel assemblies.



## Geometric Quick-Connect Key Style Finish Assembly

Figure 5-4. Geometric Quick-Connect Key Style Finish Assembly

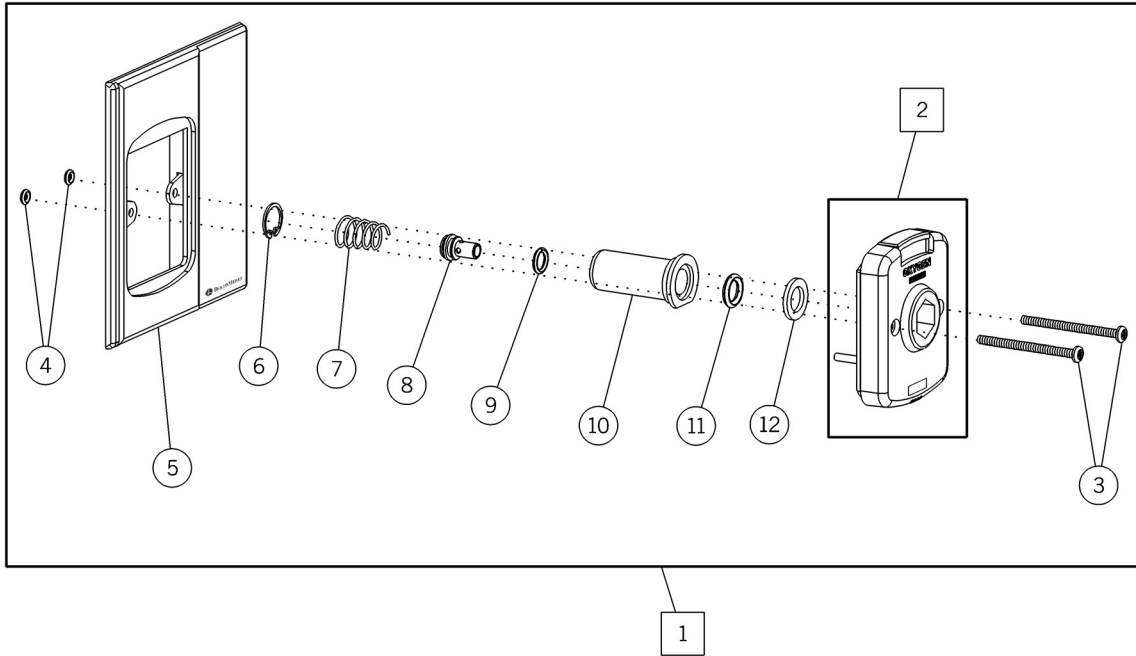

Table 5-5. Geometric Quick-Connect Key Style Finish Assembly

	Part Number	Quantity	Description
1	6803-8122-800 or 6803-8122-801 or 6803-8122-802 or 6803-8122-803 or 6803-8122-806 or 6803-8122-808 or 6803-8122-809 or 6803-8122-810 or 6803-8122-811	1	O <sub>2</sub> finish assembly—green/white N <sub>2</sub> O finish assembly—blue/white VAC finish assembly—white/black Air finish assembly—yellow/black WAGD finish assembly—violet/white O <sub>2</sub> -ISO finish assembly—white/green Air-ISO finish assembly—white/black Vac-ISO finish assembly—yellow/black AGSS-ISO finish assembly—violet/white

Item Number	Part Number	Quantity	Description
2	6803-8112-900 or 6803-8112-901 or 6803-8112-902 or 6803-8112-903 or 6803-8112-908 or 6803-8112-909 or 6803-8112-910	1	Frontbody keying disc assembly—O <sub>2</sub>  Frontbody keying disc assembly—N <sub>2</sub> O  Frontbody keying disc assembly—VAC  Frontbody keying disc assembly—Air outlet  Frontbody keying disc assembly—O <sub>2</sub> -ISO  Frontbody keying disc assembly—Air-ISO  Frontbody keying disc assembly—Vac-ISO
3	6812-2001-003	2	Screw—pan PH SST 6-32 x 1-7/8
4	0210-0559-300	2	O-ring, screw retainer
5	6803-2000-205	1	Faceplate, outlet, powder coated
6	6812-2001-007◆+	1	Retaining ring
7	6812-2001-009◆+	1	Spring—frontbody secondary piston
8	6803-2000-194+	1	Piston—Geometric Key frontbody
9	0210-0601-300w+	1	O-Ring
10	6803-2000-177+	1	Barrel—Geometric Key frontbody
11	6812-2110-003+	1	O-ring
12	6812-2000-999+	1	Washer

◆ Included within the frontbody repair kit. See table 5-23 on page 5-32 for details.

+ Included within the replacement twist-lock barrel assembly (not available for WAGD/AGSS).  
See table 5-22 on page 5-31 for details.

---

# Gas Service Rough-In Assembly

Figure 5-5. Gas Service Rough-In Assembly

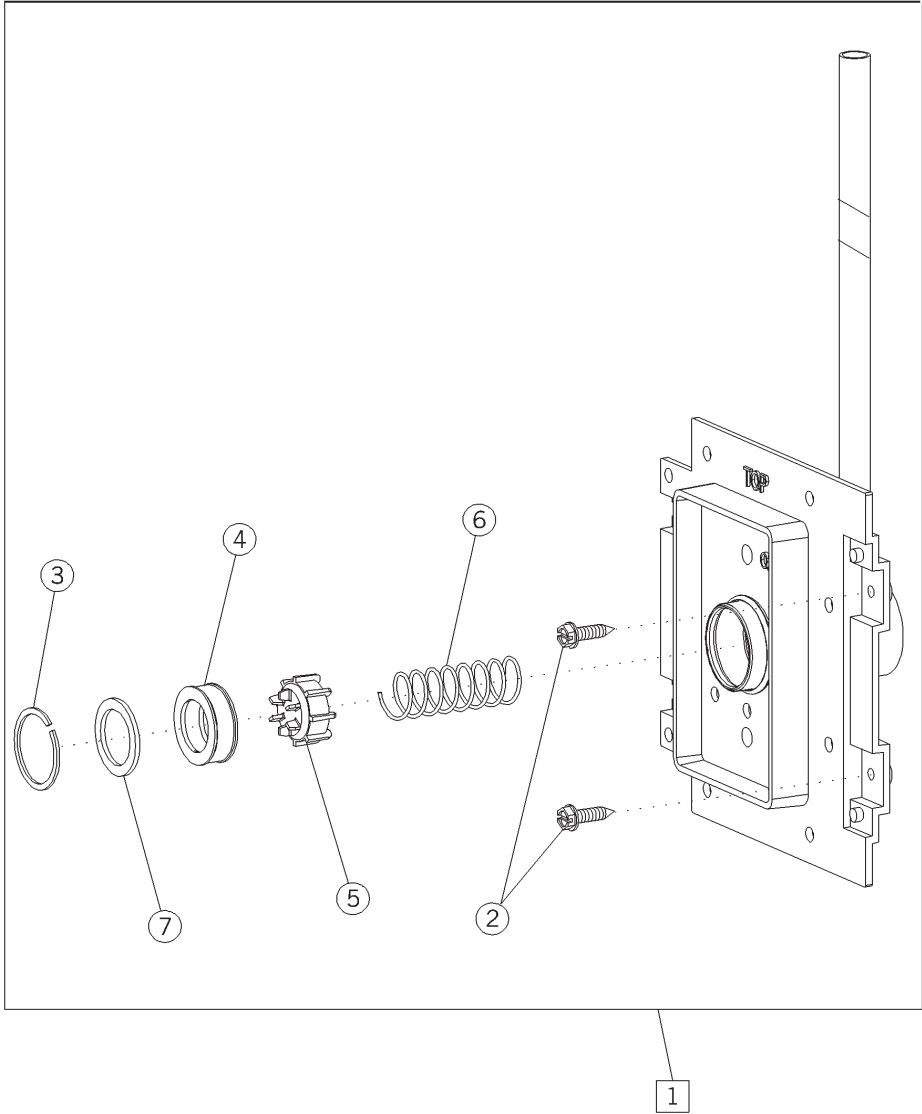

Table 5-6. Gas Service Rough-In Assembly

Item Number	Part Number	Quantity	Description
1	6803-8139-800 or 6803-8139-801 or 6803-8139-802 or 6803-8139-803 or 6803-8139-804 or 6803-8139-805 or 6803-8139-806 or 6803-8139-807	1	O <sub>2</sub> outlet assembly N <sub>2</sub> O outlet assembly VAC outlet assembly Air outlet assembly CO <sub>2</sub> outlet assembly N <sub>2</sub> outlet assembly WAGD outlet assembly O <sub>2</sub> /CO <sub>2</sub> outlet assembly
2	6812-2000-075	2	Screw, #8 x 5/8
3	6812-2001-004◆	1	Retaining ring
4	6812-2001-037◆	1	Bushing
5	6803-2000-199◆	1	Secondary check (not used in VAC, WAGD, or AGSS)
6	0203-3508-300◆	1	Spring (not used in VAC, WAGD, or AGSS)
7	6812-2000-851◆	1	Washer
8	6812-2160-008+	As required	Lubricant, Krytox®

+ Item 8 is not shown in figure 5-5 on page 5-14.

◆ Included within the rough-in assembly repair kit. See table 5-24 on page 5-33 for details.

## Twist-Lock Finish Assembly

Figure 5-6. Twist-Lock Finish Assembly

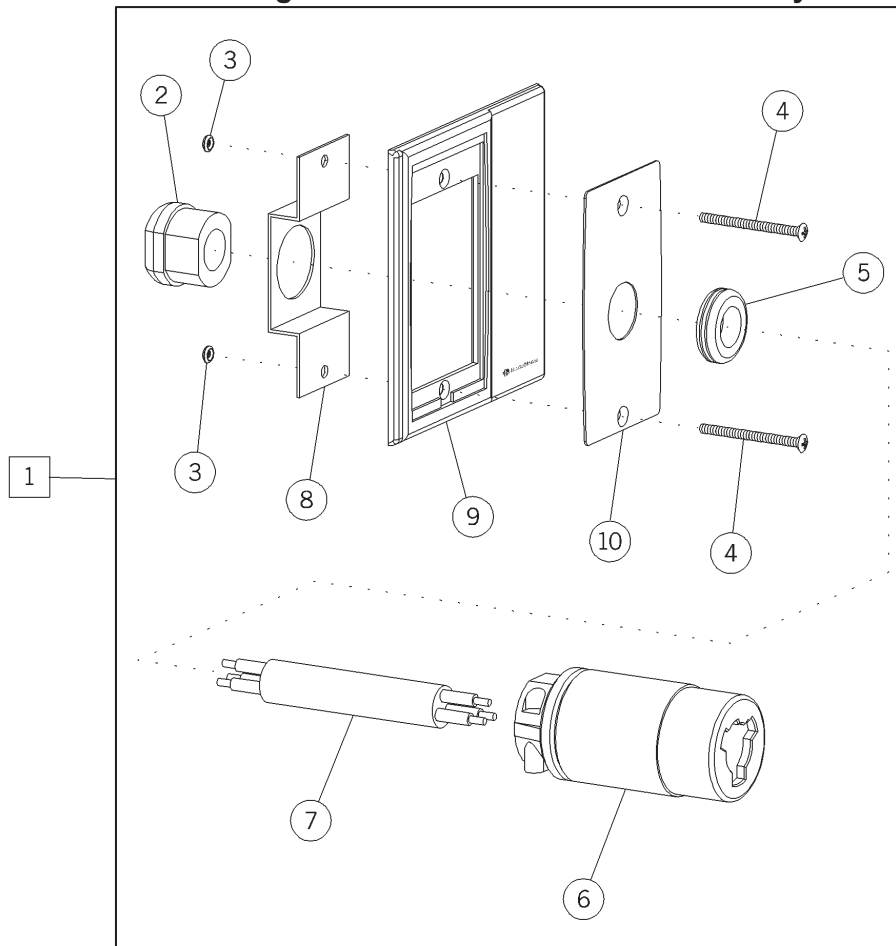
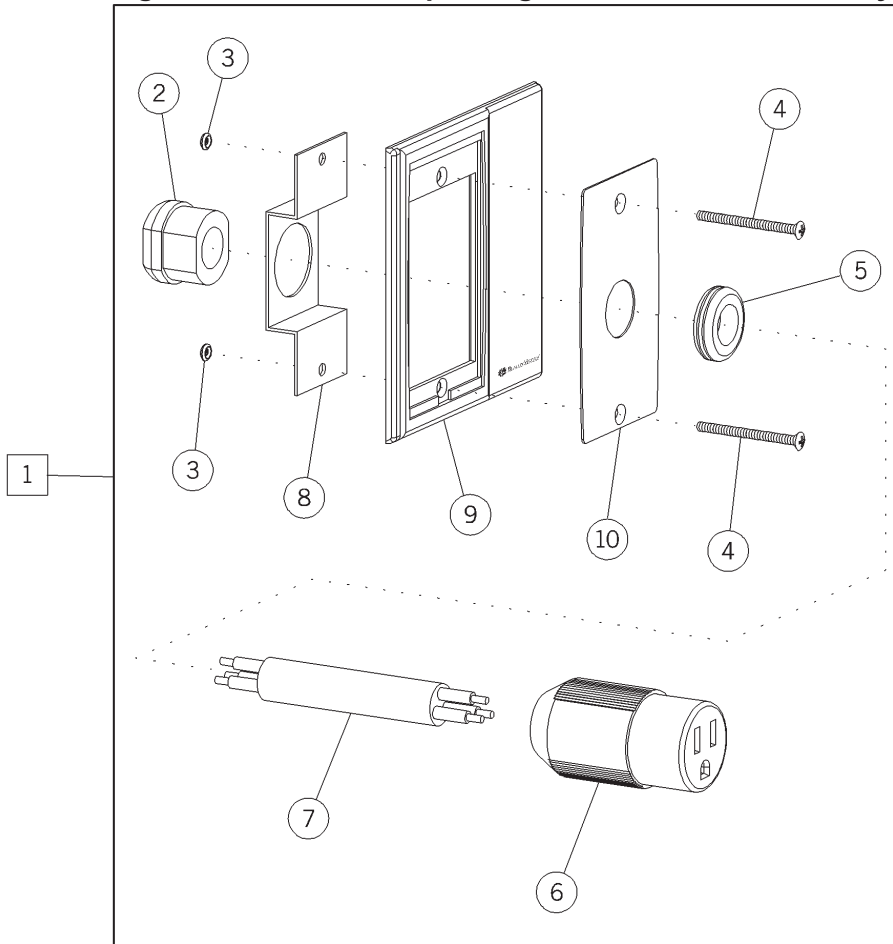

Table 5-7. Twist-Lock Finish Assembly

Item Number	Part Number	Quantity	Description
1	6803-8030-272	1	Power drop twist lock frontbody assembly
2	0208-0600-300	1	Strain relief
3	0210-0559-300	2	O-ring, screw retainer
4	6812-2001-002	2	Screw—oval PH SST #6 x 1-3/4 type F
5	0211-1492-300	1	Grommet
6	0208-0502-300	1	Receptacle, twist lock
7	0999-7996-010	As required	Cable, flexible 12 AWG type SOW
8	6812-2540-007	1	Bracket, cord mounting
9	6803-2000-206	1	Faceplate, outlet, powder coated
10	6812-2540-005	1	Finish plate

## Power Drop Straight Blade Finish Assembly

**Figure 5-7. Power Drop Straight Blade Finish Assembly**

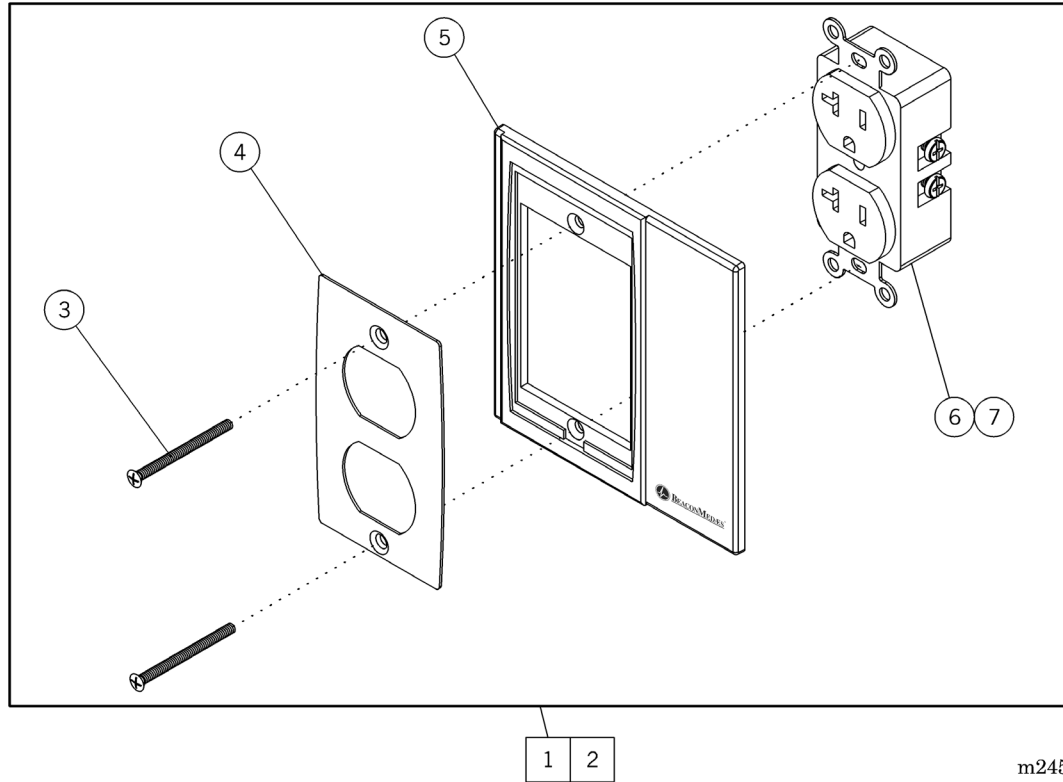

**Table 5-8. Power Drop Straight Blade Finish Assembly**

	Part Number	Quantity	Description
1	6803-8030-267	1	Power drop straight blade frontbody assembly
2	0208-0600-300	1	Strain relief
3	0210-0559-300	2	O-ring, screw retainer
4	6812-2001-002	2	Screw—oval PH SST #6 x 1-3/4 type F
5	0211-1492-300	1	Grommet
6	0208-0501-300	1	Receptacle, straigh blade
7	0999-7996-010	As required	Cable, flexible 12 AWG type SOW
8	6812-2540-007	1	Bracket, cord mounting
9	6803-2000-206	1	Faceplate, outlet, powder coated
10	6812-2540-005	1	Finish plate

## Duplex Receptacle Finish Assembly

Figure 5-8. Duplex Receptacle Finish Assembly



m245a020

Table 5-9. Duplex Receptacle Finish Assembly

Item Number	Part Number	Quantity	Description
1	675E01	1	Duplex receptacle, frontbody assembly— Ivory—20A
2	675E02	1	Duplex receptacle, frontbody assembly— Red—20A
3	6812-2001-002	2	Screw—oval PH SST #6 x 1-3/4 type F
4	6803-2000-002	1	Finish plate, electrical
5	205454	1	Faceplate, duplex receptacle
6	205556	1	Receptacle, Duplex straight blade—Ivory (included with assembly 675E01)
7	205557	1	Receptacle, Duplex straight blade—Red (included with assembly 675E02)

**Outlet—GFCI Finish Assembly**

**Figure 5-9. Outlet—GFCI Finish Assembly**

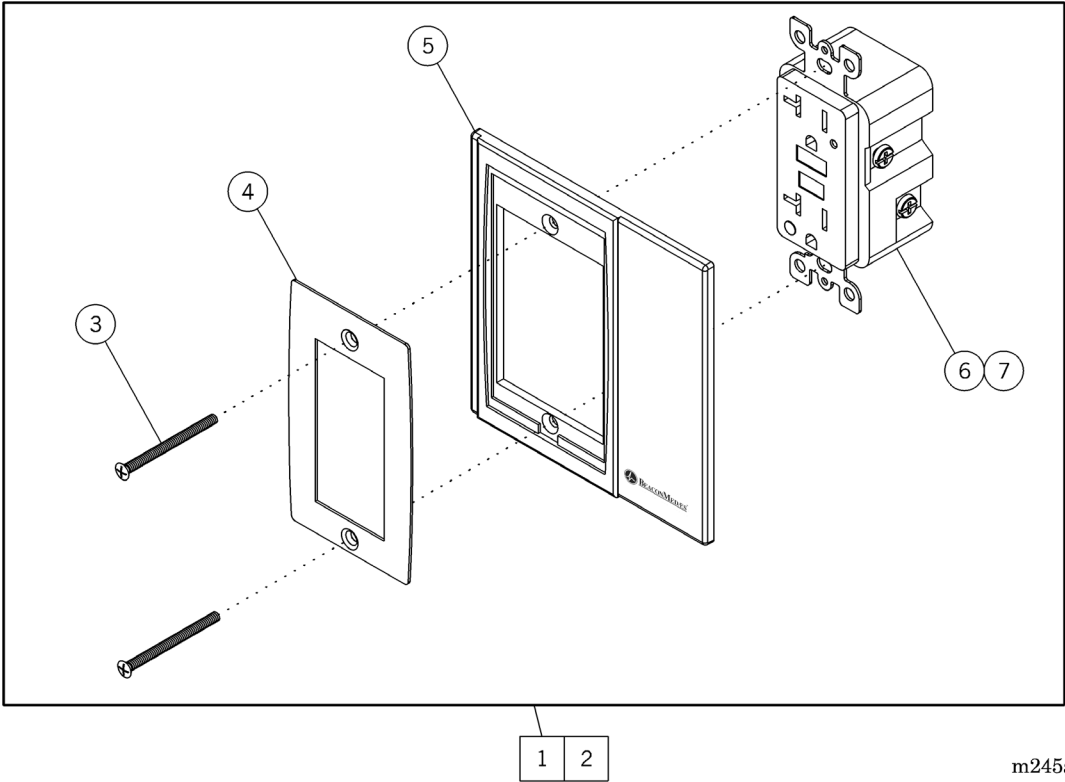

**Table 5-10. Outlet—GFCI Finish Assembly**

Item Number	Part Number	Quantity	Description
1	675E07	1	GFCI receptacle, frontbody assembly— Ivory—20A
2	675E06	1	GFCI receptacle, frontbody assembly— Red—20A
3	6812-2001-002	2	Screw—oval PH SST #6 x 1-3/4 type F
4	6803-2000-206	1	Finish plate, electrical
5	205552	1	Faceplate, switch, Decora®
6	50136	1	Receptacle, GFCI—Ivory (included with assembly 675E07)
7	54743	1	Receptacle, GFCI—Red (included with assembly 675E08)



## Toggle Switch Finish Assembly

Figure 5-10. Toggle Switch Finish Assembly

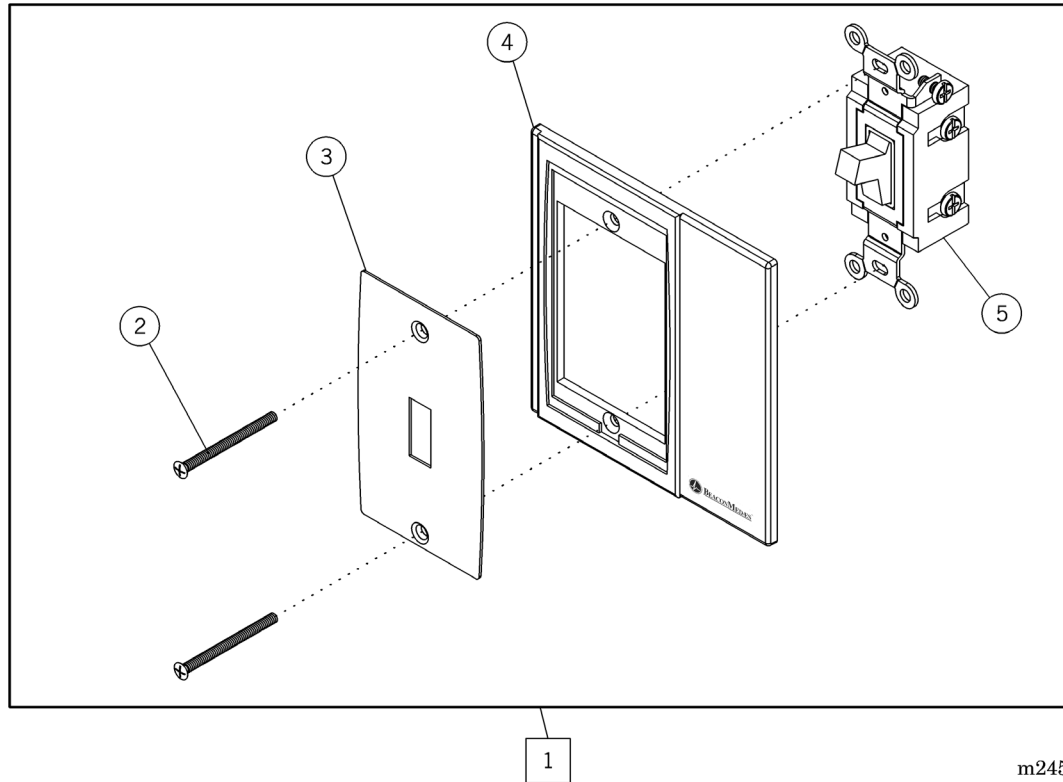

m245a024

Table 5-11. Toggle Switch Finish Assembly

Item Number	Part Number	Quantity	Description
1	675E03	1	Toggle switch, frontbody assembly
2	6812-2001-002	2	Screw—oval PH SST #6 x 1-3/4 type F
3	6803-2000-206	1	Finish plate, electrical
4	205551	1	Faceplate, switch, toggle
5	56824	1	Switch, toggle, 3-way

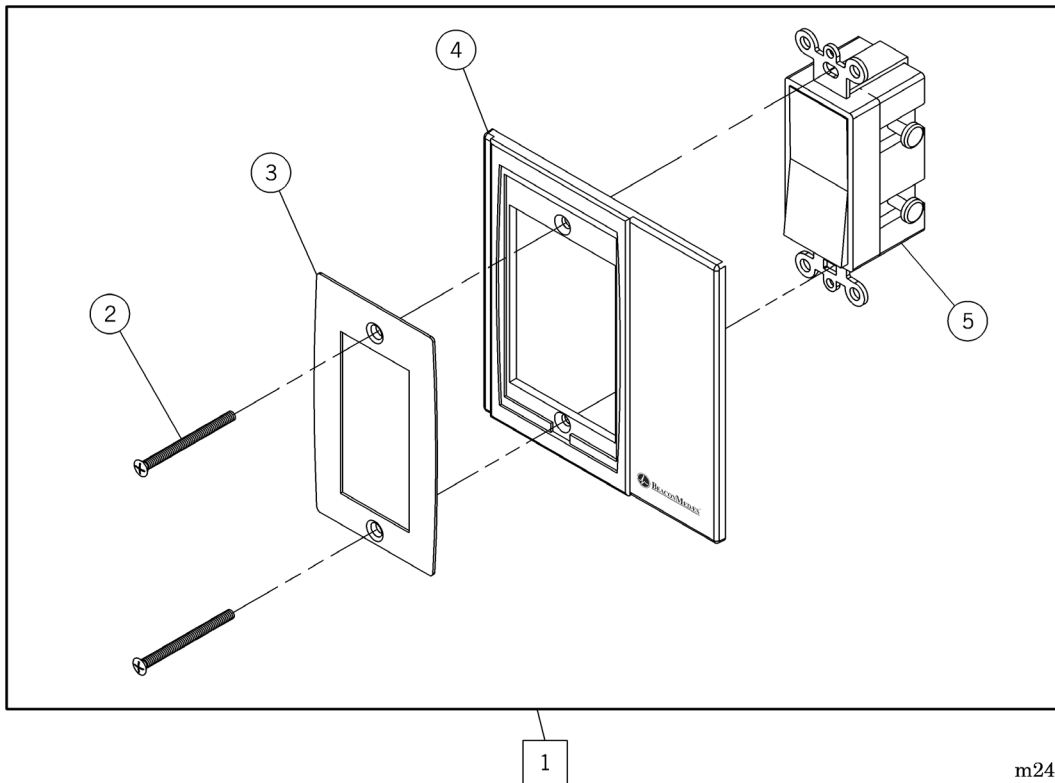
**Decora® Switch Finish Assembly****Figure 5-11. Decora® Switch Finish Assembly**

m245a025

**Table 5-12. Decora® Switch Finish Assembly**

Item Number	Part Number	Quantity	Description
1	675E04	1	Decora® switch, frontbody assembly
2	6812-2001-002	2	Screw—oval PH SST #6 x 1-3/4 type F
3	6803-2000-206	1	Finish plate, electrical
4	205552	1	Faceplate, switch, Decora®
5	205555	1	Switch, Decora®, 3-way, 20A

**5**

## Low Voltage Switch Finish Assembly

Figure 5-12. Low Voltage Switch Finish Assembly

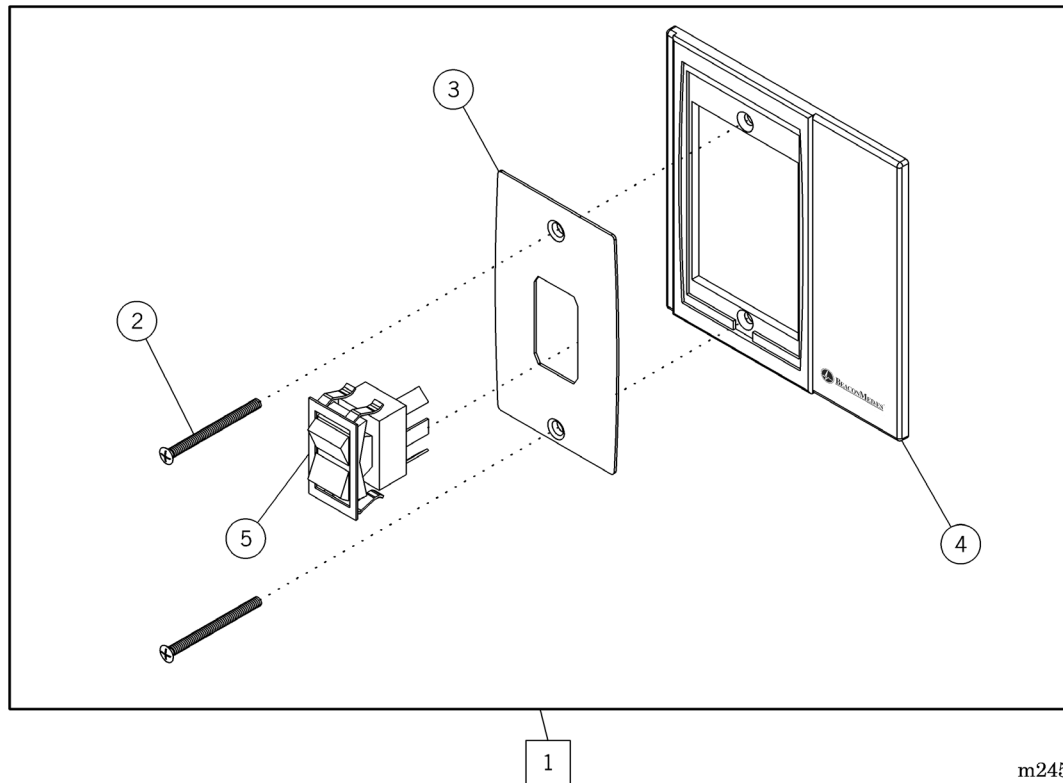

m245a035

Table 5-13. Low Voltage Switch Finish Assembly

Item Number	Part Number	Quantity	Description
1	675E05	1	Low voltage switch, frontbody assembly
2	6812-2001-002	2	Screw—oval PH SST #6 x 1-3/4 type F
3	6803-2000-206	1	Finish plate, electrical
4	205550	1	Faceplate, switch, low voltage
5	204662	1	Switch, rocker momentary

## Blank Provision Finish Assembly

Figure 5-13. Blank Provision Finish Assembly

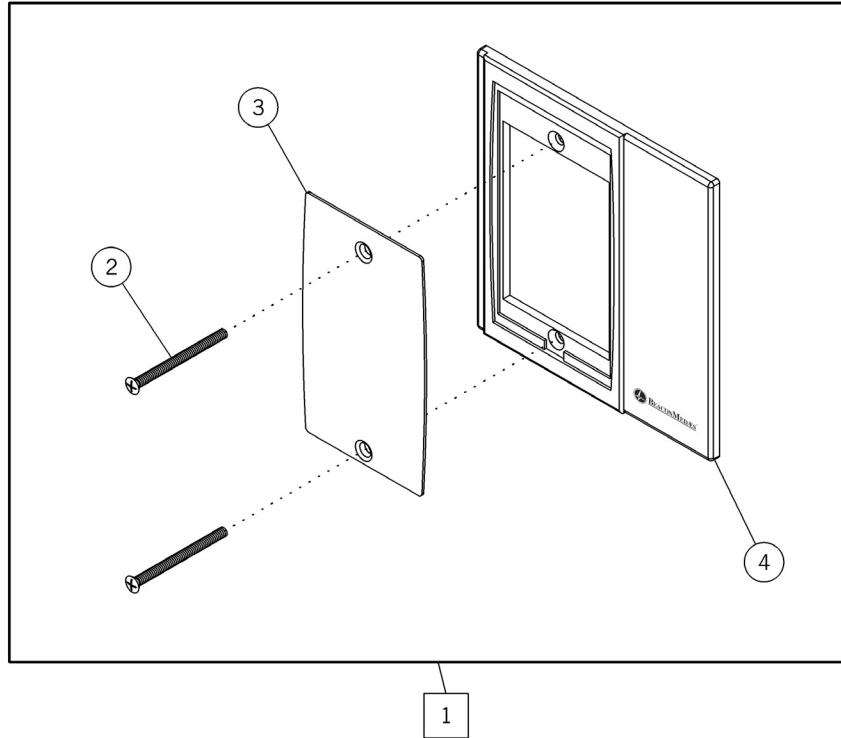

m245a036

Table 5-14. Blank Provision Finish Assembly

Item Number	Part Number	Quantity	Description
1	675E06	1	Blank provision, frontbody assembly
2	6812-2001-002	2	Screw—oval PH SST #6 x 1-3/4 type F
3	6803-2000-206	1	Finish plate, electrical
4	205455	1	Faceplate, blank provision

5

## Electrical Accessories Rough-In Assembly

Figure 5-14. Electrical Accessories Rough-In Assembly

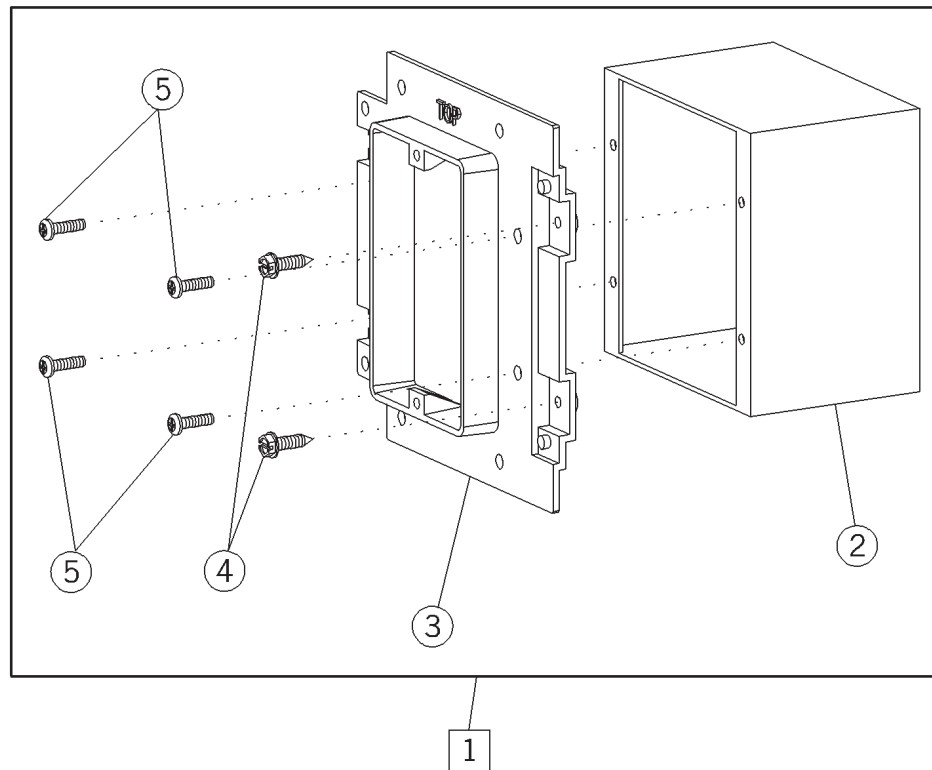
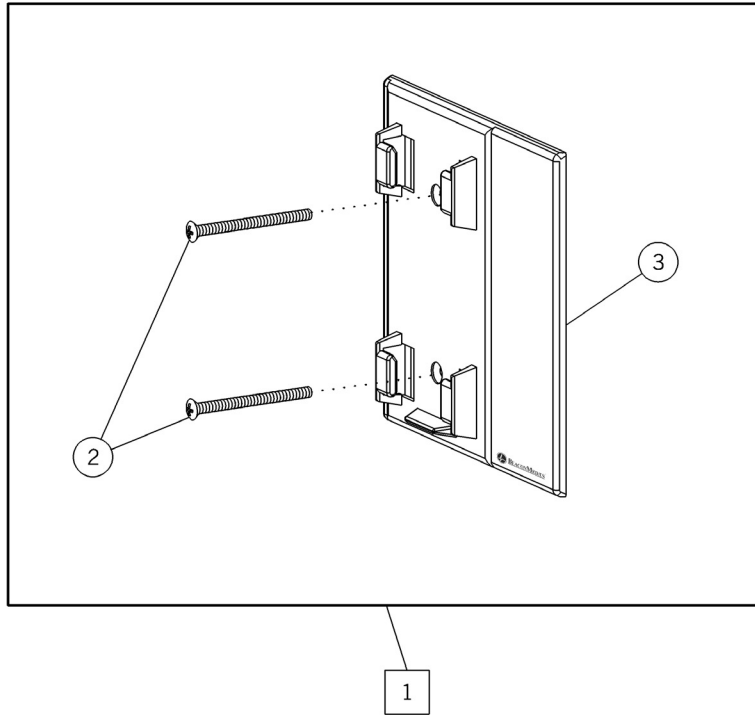

Table 5-15. Electrical Accessories Rough-In Assembly

Item Number	Part Number	Quantity	Description
1	6803-8030-270	1	Electrical accessories rough-in assembly
2	6812-2540-006	1	Junction box, electrical
3	6803-2000-277	1	Backplate, electrical accessories
4	6812-2000-075	2	Screw, #8 x 5/8
5	6812-2000-000	4	Screw, pan PH SST #6-32 x 1-7/8

## Recessed Wall Slide Finish Assembly

Figure 5-15. Recessed Wall Slide Finish Assembly



m245a021

Table 5-16. Recessed Wall Slide Finish Assembly

Item Number	Part Number	Quantity	Description
1	6803-8030-263	1	Vacuum slide outlet frontbody assembly
2	6812-2001-002	2	Screw, oval PH SST #6 x 1-3/4 type F
3	6803-2000-207	1	Faceplate, vacuum slide, powder coated

5

## Recessed Wall Blank Finish Assembly

Figure 5-16. Recessed Wall Blank Finish Assembly

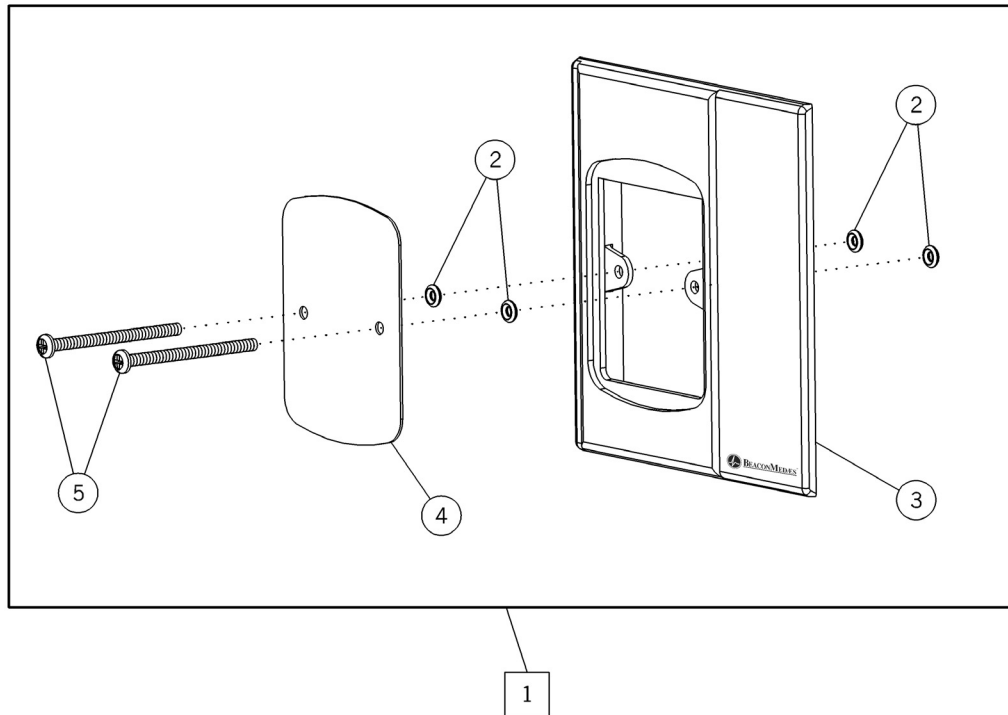

m245a031

Table 5-17. Recessed Wall Blank Finish Assembly

Item Number	Part Number	Quantity	Description
1	6803-8030-264	1	Blank outlet frontbody assembly
2	0210-0559-300	4	O-ring, screw retainer
3	6803-2000-205	1	Faceplate, gas outlet, powder coated
4	6803-2000-163	1	Plate blank, wall outlet
5	6812-2001-003	2	Screw—pan PH SST 6-32 x 1-7/8

## Recessed Wall Slide Rough-In Assembly

Figure 5-17. Recessed Wall Slide Rough-In Assembly

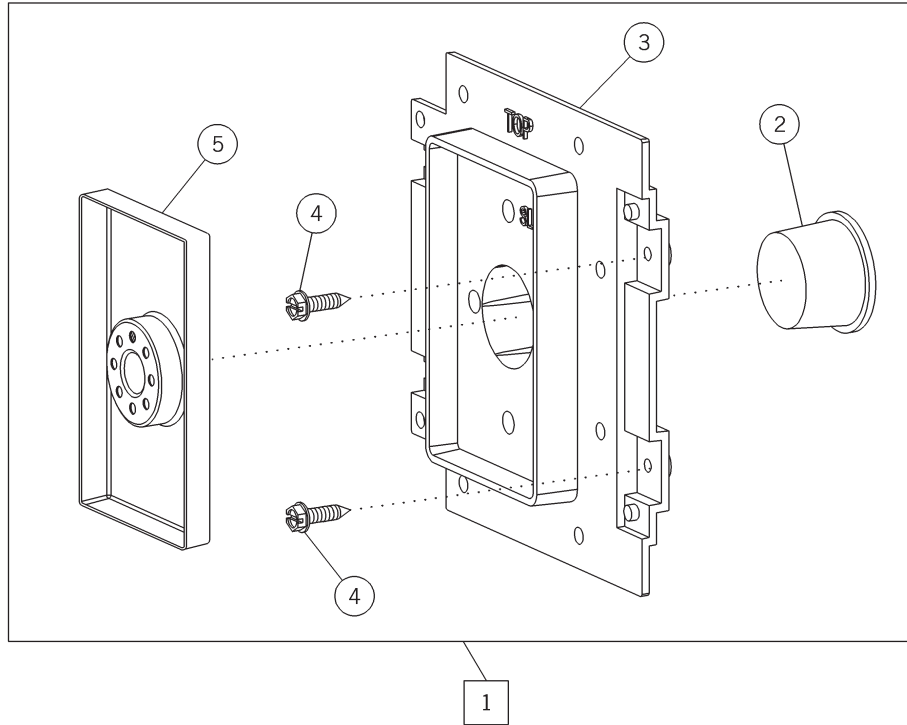

m245a015

Table 5-18. Recessed Wall Slide Rough-In Assembly

Item Number	Part Number	Quantity	Description
1	6803-8030-269	1	Vacuum slide outlet rough-in assembly
2	0203-0143-300	1	Caplug, #14 taper
3	6803-2000-276	1	Backplate, slide
4	6812-2000-075	2	Screw, #8 x 5/8
5	6803-2000-290	1	Dust cover

## Wall-Mounted Slide Finish Assembly with Anchors

**Figure 5-18. Wall-Mounted Slide Finish Assembly with Anchors**

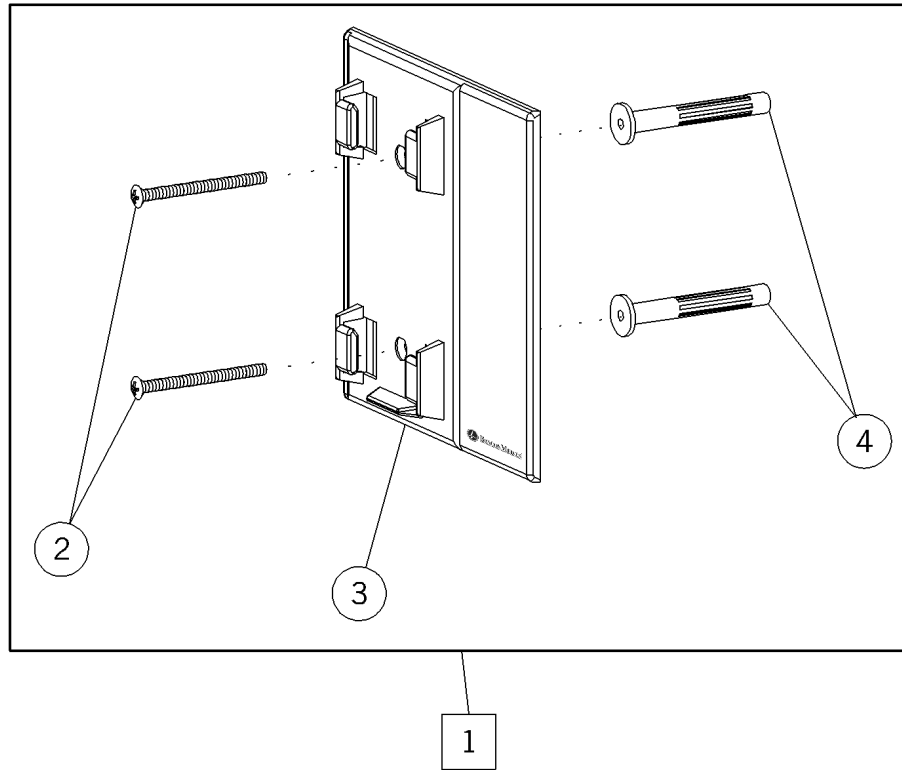
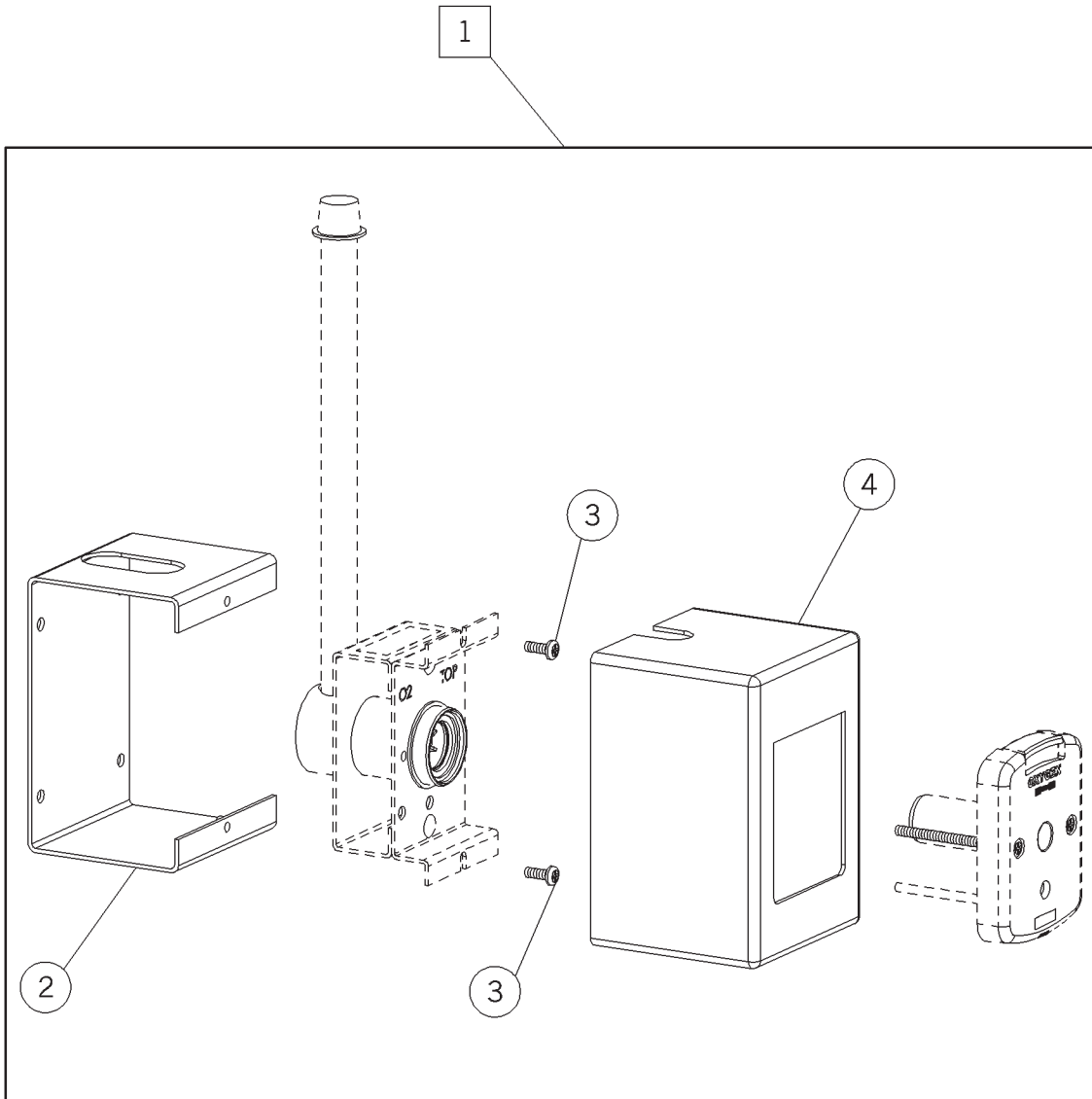

**Table 5-19. Wall-Mounted Slide Finish Assembly with Anchors**

Item Number	Part Number	Quantity	Description
1	6803-8030-268	1	Vacuum slide outlet frontbody assembly with anchors
2	6812-2001-002	2	Screw, oval PH SST #6 x 1-3/4 type F
3	6803-2000-207	1	Faceplate, vacuum slide, powder coated
4	0402-1820-300	2	Anchor

**Surface-Mounted Gas Outlet Enclosure**

**Figure 5-19. Surface-Mounted Gas Outlet Enclosure**



**5**

**Table 5-20. Surface-Mounted Gas Outlet Enclosure**

Item Number	Part Number	Quantity	Description
1	6803-8030-271	1	Kit, exposed gas outlet
2	6803-2000-288	1	Bracket, surface-mount
3	0140-6124-106	2	Screw
4	6803-2000-289	1	Box, surface-mount outlet

## Surface-Mounted Slide Enclosure

Figure 5-20. Surface-Mounted Slide Enclosure

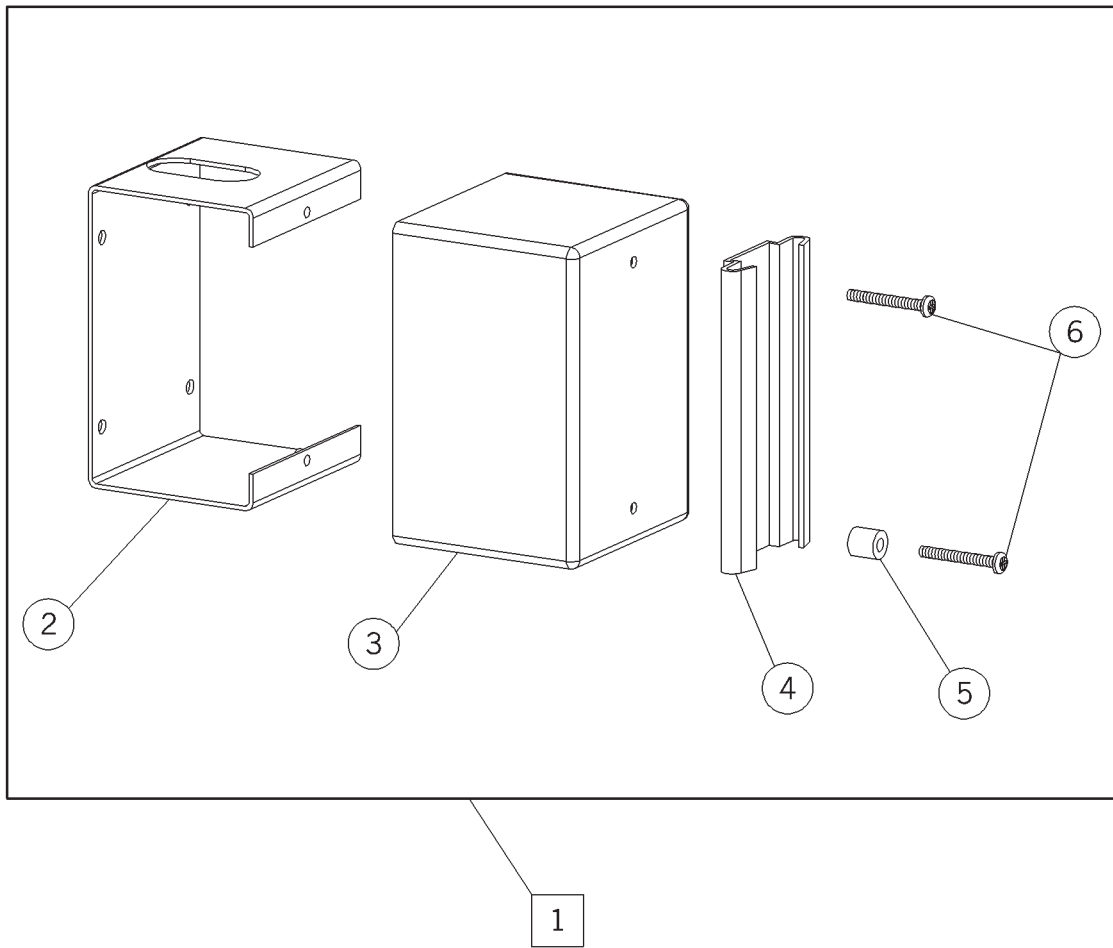

Table 5-21. Surface-Mounted Slide Enclosure

Item Number	Part Number	Quantity	Description
1	6803-8030-274	1	Kit, exposed slide
2	6803-2000-288	1	Bracket, surface-mount
3	6803-2000-290	1	Box, surface-mount slide
4	9100-1000-001	1	Slide, vacuum
5	9100-1000-000	1	Spacer, slide
6	6812-2000-970	2	Screw

## Replacement Twist-Lock Barrel Assembly Repair Kits

Figure 5-21. Replacement Twist-Lock Barrel Assembly Repair Kits

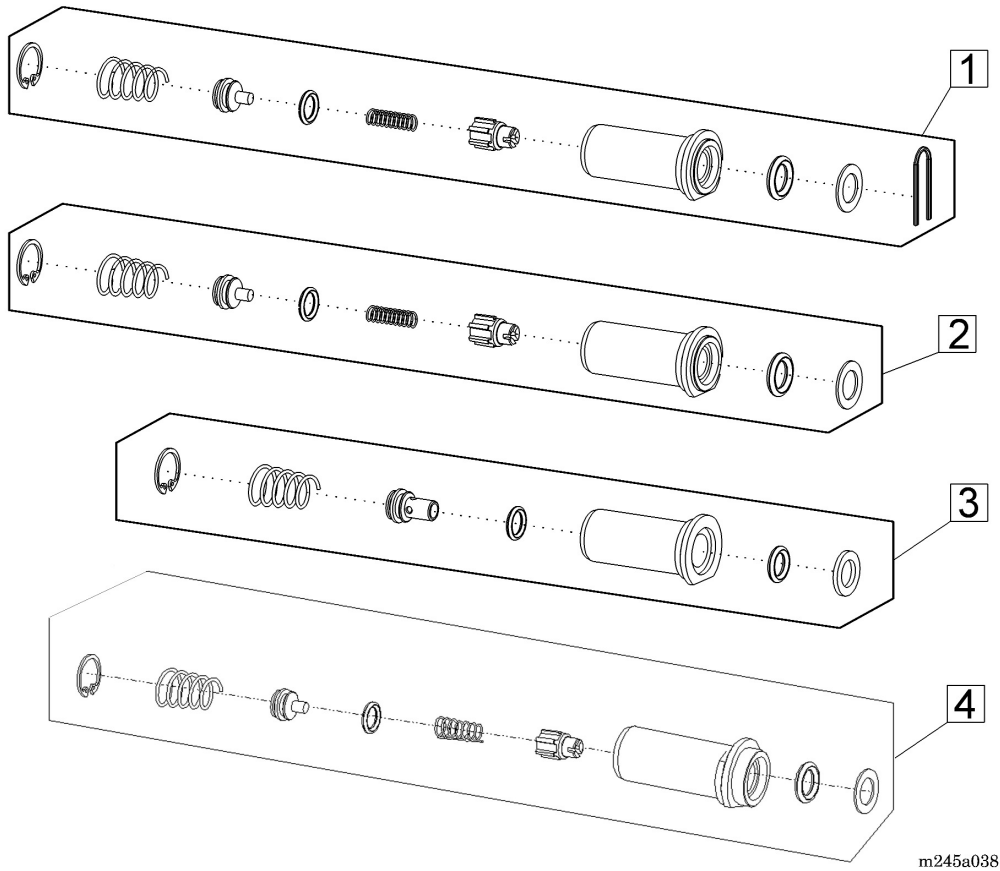
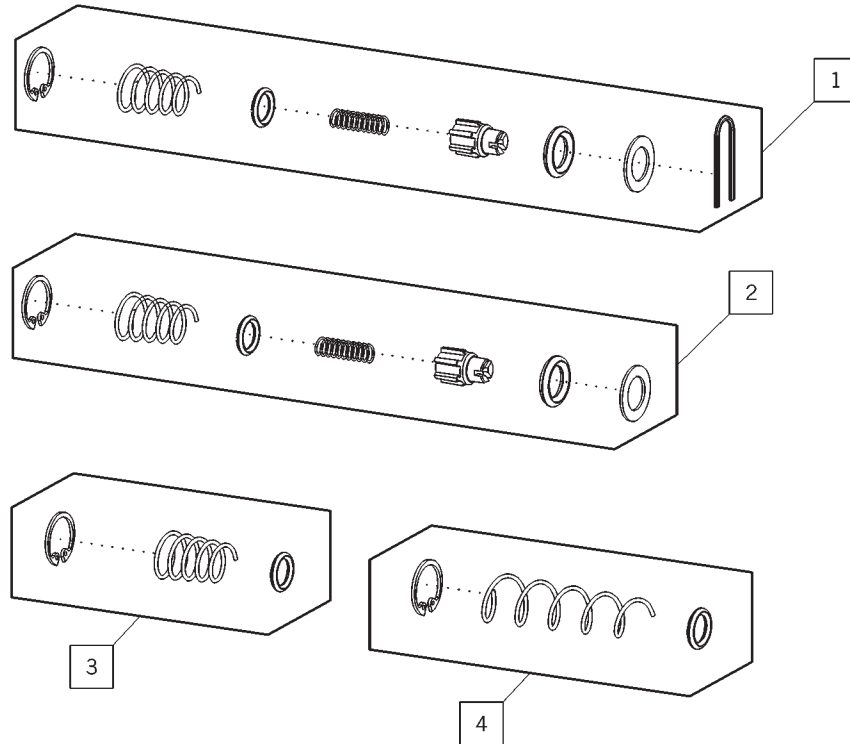

Table 5-22. Replacement Twist-Lock Barrel Assembly Repair Kits

Item Number	Part Number	Quantity	Description
1	6803-7030-121	1	Loaded barrel—Diamond® key style
2	6803-7030-122	1	Loaded barrel—Latch index key style, with Hill-Rom logo
3	6803-7030-123	1	Loaded barrel—Geometric key style (excluding WAGD)
4	6803-7030-130	1	Loaded barrel—Latch index key style, without company logo

## Frontbody Repair Parts Kits

Figure 5-22. Frontbody Repair Parts Kits



m245a040

Table 5-23. Frontbody Repair Parts Kits

Item Number	Part Number	Quantity	Description
1	6803-7030-117	1 pkg. for 10 outlets	Repair kit, frontbody—Diamond® key style
2	6803-7030-118	1 pkg. for 10 outlets	Repair kit, frontbody—Latch index key style
3	6803-7030-119	1 pkg. for 10 outlets	Repair kit, frontbody—Geomoetric key style
4	6803-7030-116	1 pkg. for 10 outlets	Repair kit, frontbody—DISS key style

## Rough-In Assembly Repair Parts Kits

Figure 5-23. Rough-In Assembly Repair Parts Kits

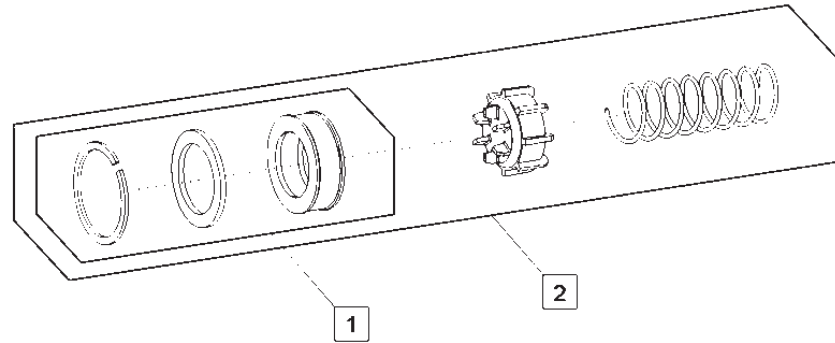

Table 5-24. Rough-In Assembly Repair Parts Kits

Item Number	Part Number	Quantity	Description
1	6803-7030-125	1 pkg. for 10 outlets	Repair kit, rough-in—Vac/WAGD/AGSS (all key styles)
2	6803-7030-124	1 pkg. for 10 outlets	Repair kit, rough-in—Pressure gases (all key styles)

## DiamondCare® Conversion Kits

Figure 5-24. DiamondCare® Conversion Kits

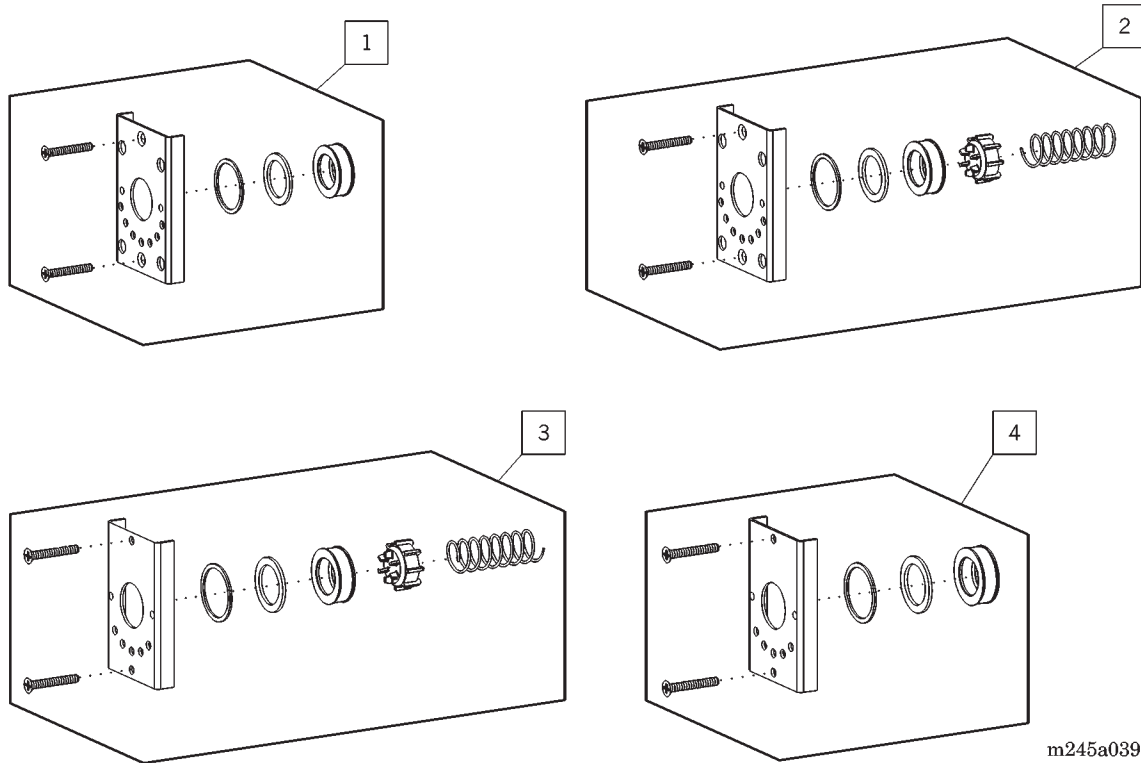

Table 5-25. DiamondCare® Conversion Kits

Item Number	Part Number	Quantity	Description
1	6803-7030-128 ♦	1	Kit, retro—Diamond®/DISS II and III <b>wall vacuum</b> rough-in assemblies
2	6803-7030-126 ♦	1	Kit, retro—Diamond®/DISS II and III <b>wall pressure</b> rough-in assemblies
3	6803-7030-127 ♦	1	Kit, retro—Diamond®/DISS II and III <b>console pressure</b> rough-in assemblies
4	6803-7030-129 ♦	1	Kit, retro—Diamond®/DISS II and III <b>console vacuum</b> rough-in assemblies

♦ Rough-in assembly conversion only. A new DiamondCare®, Diamond®, or DISS frontbody finish assembly must be separately ordered.

# Chapter 6

## General Procedures

### Chapter Contents

Cleaning.....	6-2
Steam Cleaning.....	6-2
Cleaning Hard to Clean Spots .....	6-2
Disinfection .....	6-2
Component Handling.....	6-3
Lubrication Requirements .....	6-3
Service .....	6-4
Repair Policy and Procedure .....	6-5
Repair Kits.....	6-6
General Service Procedures.....	6-7
Tool and Supply Requirements .....	6-8

## Cleaning



**WARNING:**

Follow the product manufacturer's instructions. Failure to do so could result in personal injury or equipment damage.



**CAUTION:**

Do not use harsh cleaners/detergents such as scouring pads and heavy duty grease removers, or solvents such as toluene, xylene, and acetone. Equipment damage could occur.



**CAUTION:**

Do not use oil or grease on or around the outlet. Doing so could result in equipment damage. Use only lubricants approved for oxygen service, such as Krytox® 6PL205.

If there is no visible soilage with possible blood or body fluids, we recommend that you clean the unit with a mild detergent and warm water. If disinfection is desired, you may use a combination cleanser/disinfectant as explained in "Disinfection" below.

### Steam Cleaning

Do not use any steam cleaning device on the DiamondCare® Recessed Wall Outlets. Excessive moisture can damage mechanisms in this unit.

### Cleaning Hard to Clean Spots

To remove difficult spots or stains, we recommend that you use standard household cleansers and a soft-bristled brush. To loosen heavy, dried-on soil, you may first need to saturate the spot.

### Disinfection

Before applying disinfectant chemicals, ensure that they are compatible with ABS and polycarbonate plastics, and die cast zinc. Be aware that as disinfectants dry on a surface, concentrations up to 100% can be achieved.

Quaternary ammonium agents may cause degradation of plastics.

## Component Handling

---



**CAUTION:**

When testing an outlet for correct operation, do not allow the piston in the check valve to "snap" back into position. The shoulder on the piston can break, causing leakage.



**WARNING:**

Particular caution must be taken to provide frequent inspection and service of the air outlets where DiamondCare® outlets are used in an air system supplied by a liquid ring air compressor that uses chlorinated water, and having galvanized piping or a galvanized air receiver. Chemical reactions occurring under those conditions may damage the pistons. Air outlets should be examined at least annually, and pistons that show evidence of deterioration should be replaced. Failure to do so could result in personal injury or equipment damage.

## Lubrication Requirements

---



**WARNING:**

Follow the product manufacturer's instructions. Failure to do so could result in personal injury or equipment damage.



**CAUTION:**

Do not use silicone-based lubricants. Equipment damage could occur.

## Service



**WARNING:**

Only facility-authorized personnel should service the DiamondCare® Recessed Wall Outlets. Service performed by unauthorized personnel could result in personal injury or equipment damage.

For standard guidelines in properly maintaining the gas outlets, refer to CGA Pamphlet E-10 (1999 Edition), *Maintenance of Medical Gas and Vacuum Systems in Health Care Facilities*.

Include the following when servicing the DiamondCare® Recessed Wall Outlets:

- Inspect the finish faceplate and replace if necessary.
- Inspect all labels and replace if necessary.
- Check the general aesthetics of the DiamondCare® Recessed Wall Outlets.

---

## Repair Policy and Procedure



### CAUTION:

No repair should ever be undertaken or attempted by anyone not meeting the qualifications of or complying with the BeaconMedæs repair policy and procedures. Failure to do so could result in equipment damage.

- Do not use malfunctioning equipment.
- To ensure full reliability, have all repairs and service done by an authorized BeaconMedæs service representative. If this cannot be done, replacement and service of those parts listed in this manual can be done by a competent, trained individual having experience in the repair of devices of this nature.
- After any repair, test the equipment to ensure that it is functioning properly and in accordance with the manufacturer's published specifications.
- Replace damaged parts with components manufactured or sold by BeaconMedæs. Then test the unit to make sure that it complies with the manufacturer's published specifications.
- Contact BeaconMedæs at 1-(888) 4-MEDGAS (463-3427) for assistance.
- If you send a damaged assembly to a BeaconMedæs service center, package it securely in the original shipping container, if possible, and ship it prepaid. Enclose a letter with the assembly describing the problem and the repairs felt necessary.
- In cases not covered by the BeaconMedæs Limited Warranty Policy, repairs will be made according to the BeaconMedæs current list price for the replacement part(s), plus a reasonable labor charge.

## Repair Kits

BeaconMedæ provides separate repair kits for these DiamondCare® frontbody and rough-in assemblies:

- Replacement Twist-Lock Barrel Assembly
  - Diamond® Key Style
  - Latch Index Key Style
  - Geometric Key Style (excluding WAGD)
- Frontbody Repair Parts Kit
  - Diamond® Key Style
  - Latch Index Key Style
  - Geometric Key Style
  - DISS Key Style
- Rough-in Assembly Repair Parts Kit
  - Pressurized gases (all key styles)
  - Vacuum, WAGD, and AGSS (all key styles)
- DiamondCare® Conversion Kit
  - Diamond®/DISSII and III wall rough-in assemblies ♦
- Pressure gases
- Vacuum, WAGD, and AGSS
  - Diamond®/DISSII and III console rough-ins assemblies ♦
  - Pressure gases
  - Vacuum, WAGD, and AGSS
- ♦ Rough-in assembly conversion only. A new DiamondCare®, Diamond®, or DISS frontbody finish assembly must be separately ordered.

## 6.1 General Service Procedures



### CAUTION:

Only authorized and trained personnel should perform the service procedures. (The service procedures in Chapter 4 can be followed by individuals who have general knowledge and experience with devices of this nature.) No repairs or service should be attempted by anyone not having such qualifications.



### WARNING:

Where DiamondCare® Recessed Wall Outlets are used in an air system supplied by a liquid ring air compressor that uses chlorinated water, and has galvanized piping or a galvanized air receiver, particular caution must be taken to frequently inspect and maintain of the air outlets. Chemical reactions occurring under those conditions may damage the pistons. Failure to maintain the air outlets could result in personal injury or equipment damaged.

1. Examine air outlets at least annually, and replace pistons that show evidence of deterioration. If deterioration is noted, examine the outlets quarterly.
2. Use only genuine replacement parts manufactured or sold by BeaconMedæx for all outlet repairs.
3. Read completely through each procedure before starting the procedure. Any exceptions may result in failure to properly and safely complete the procedure attempted.



### CAUTION:

When testing an outlet for correct operation, do not allow the piston in the check valve to "snap" back into position. The shoulder on the piston can break, causing leakage.

## **Tool and Supply Requirements**

---

To service the DiamondCare® Recessed Wall Outlets, the following tools are required:

- Retaining ring removal/installation tool (appropriate type/size)
- #2 phillips head screwdriver
- Screwdriver
- Small screwdriver
- Needle nose pliers
- Hand-held power drill

**NOTES:**

---

6



*Corporate Headquarters:*

BeaconMedæS  
1800 Overview Drive  
Rock Hill, SC 29730  
Phone (803) 817-5600  
Fax (803) 817-5750

**For technical support or to  
place an order call:**

1 888 4 MEDGAS  
(1 888 463 3427)

Fax (803) 817 5750

[www.beaconmedaes.com](http://www.beaconmedaes.com)