

Installation, Operation and Maintenance Instructions

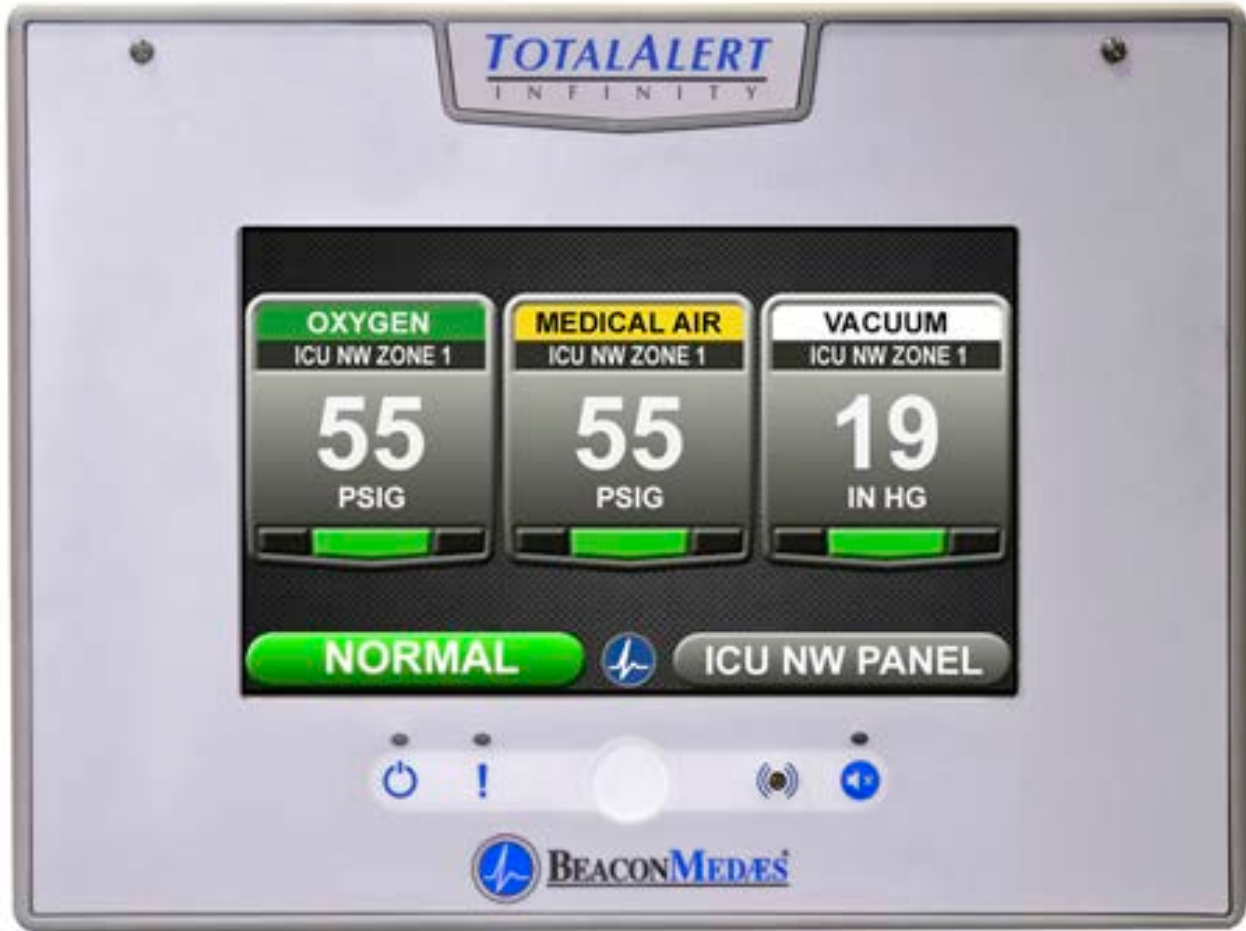

TotalAlert Infinity™ NFPA Medical Gas Notification System

Part number 4107 9016 58

Revision 03

August 31, 2015



Installation, Operation and Maintenance Manual

TotalAlert Infinity™ NFPA Medical Gas Notification System

This unit is purchased from: _____

Date purchased: _____

Model number: _____

Part number: _____

Option(s) included: _____

Any information, service or spare parts requests should be directed to:

BeaconMedæS
1800 Overview Drive
Rock Hill, SC 29730

Telephone: (888) 463-3427
Fax: (803) 817-5750

BeaconMedæS reserves the right to make changes and improvements to update products sold previously without notice or obligation.

Part number 4107 9016 58
Revision 03
August 31, 2015

Table of Contents

1.0 Introduction

- 1.1 Product Identification
- 1.2 User Interface Layout
 - 1.2.1 TotalAlert Infinity™ Features
 - 1.2.2 Master Alarm
 - 1.2.3 Area Alarm
 - 1.2.4 Combination Alarm
 - 1.2.5 Boards
- 1.3 Definition of Statements
- 1.4 Definitions
- 1.5 Alarm Configurations
 - 1.5.1 Master Alarms
 - 1.5.2 Area Alarms
 - 1.5.3 Gas Combination Alarms
- 1.6 TotalAlert Infinity™ Medical Gas Notification System Parent Model Number Chart

2.0 Installation Procedures

- 2.1 Alarm Panel Rough-In Box
- 2.2 Gas Sensor Installation
 - 2.2.1 Locally Installed Sensors
 - 2.2.2 Remotely Installed Sensors in Pipeline
 - 2.2.3 Remotely Installed Sensors in Zone Valve Box
- 2.3 Wiring
 - 2.3.1 General Requirements
 - 2.3.2 Wire Type And Size
 - 2.3.3 Determining Number Of Conductors
 - 2.3.4 Power Supply
 - 2.3.5 B60 Gas Input Board
 - 2.3.6 B1X Signal Input Board
 - 2.3.7 B4X Relay Output Board
 - 2.3.8 B50 4-20mA Combination Board
 - 2.3.9 Alarm Panel “Mirroring”
 - 2.3.10 General Fault Relay
 - 2.3.11 Ethernet
 - 2.3.12 Field Wiring Cable Shield Grounding
 - 2.3.13 BACnet

Table of Contents (continued)

- 2.4 Finish Assembly
 - 2.4.1 Front Panel Mounting
 - 2.4.2 Locally Installed Sensors
 - 2.4.3 Remotely Installed Sensors in Pipeline

3.0 Wiring Schematics

- 3.1 NFPA Master Wiring Diagram
- 3.2 NFPA Area Wiring Diagram
- 3.3 NFPA Combination Wiring Diagram

4.0 Operation

- 4.1 Overview
 - 4.1.1 Main Screen
 - 4.1.2 Gas Badge
 - 4.1.3 Source Signals
 - 4.1.4 TotalAlert Infinity™ Consolidated Badge
 - 4.1.5 Toolbar
 - 4.1.6 Fault Status
 - 4.1.7 Display Screens
- 4.2 Alarm Configuration
- 4.3 Setting Up an Area Alarm
 - 4.3.1 Configuring Gas ID Badges
 - 4.3.2 Initial Setup of an Unconfigured Area Alarm
- 4.4 Setting Up a Master Alarm
 - 4.4.1 Configuring Source Badges
 - 4.4.2 Initial Setup of an Unconfigured Master Alarm
- 4.5 Setting Up a Combination Alarm
 - 4.5.1 Configuring Source Badges
 - 4.5.2 Configuring Gas ID Badges
 - 4.5.3 Initial Setup of an Unconfigured Combination Alarm
 - 4.5.4 Miscellaneous Tab
- 4.6 Customized Instructions Set Up
- 4.7 Additional Components
 - 4.7.1 4-20 mA Devices
 - 4.7.2 Relay Output Board (B4X Board)
 - 4.7.3 Wired Ethernet Setup
 - 4.7.4 BACnet Set-Up
 - 4.7.5 “Mirroring” Two Alarm Panels

TotalAlert Infinity™ NFPA Medical Gas Notification System

4.8 Website

4.8.1 Navigating the Website

4.8.2 Website Set-Up

4.9 Wireless Ethernet Set-Up

5.0 Retrofit

5.1 Retrofit of TotalAlert² Master Alarm Panel (32 points or 64 points)

5.1.1 Remove Components from Existing Alarm

5.1.2 Install New Components

5.2 Retrofit of TotalAlert² Area Alarm Panel (4-gas, 8-gas) and MEGA2 Alarms

5.2.1 Remove Components from Existing Alarm

5.2.2 Install New Power Supply

5.2.3 Install New Components

5.2.4 Install Trim Plate

5.3 Retrofit of TotalAlert¹ Alarm Panels

5.3.1 Remove Components from Existing Alarm

5.3.2 Install Gas-Specific Sensors (Area or Combination alarms only)

5.3.3 Install New Power Supply

5.3.4 Install New Components

5.3.5 Install Trim Plate

5.4 Retrofit of Other Alarm Panels

5.4.1 Remove Components from Existing Alarm

5.4.2 Determine Proper Placement of New Components

5.4.3 Install Gas-Specific Sensors (Area or Combination alarms only)

5.4.4 Install New Power Supply

5.4.5 Install I/O Modules

5.4.6 Install Trim Components

5.4.7 Install Front Panel

6.0 Maintenance

7.0 Troubleshooting

8.0 Master Alarm Signal Input Data

1.0 Introduction

1.1 Product Identification

Each alarm is identified by a Model number, Part number, and Lot Code.

Installation procedures vary depending on the alarm configuration.

The product ID label is located on the inside of the alarm back box (Figure 1).

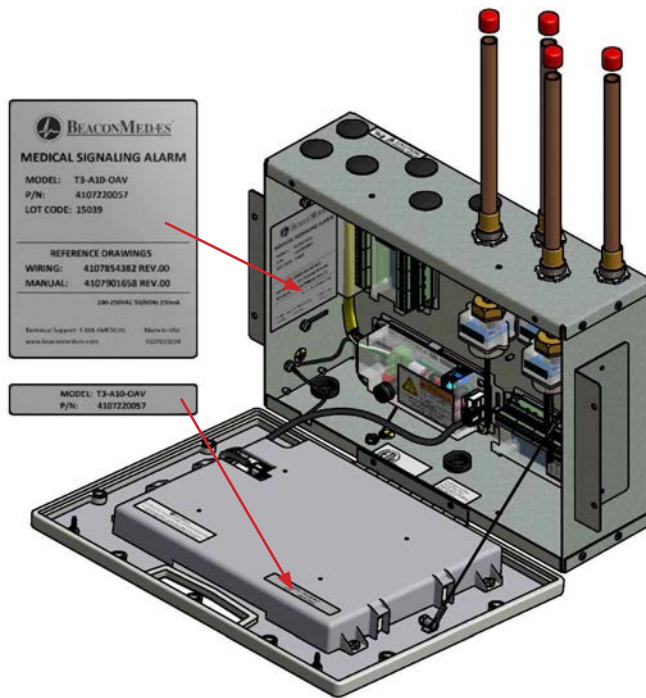

Figure 1: Product Identification Labels

1.2 User Interface Layout

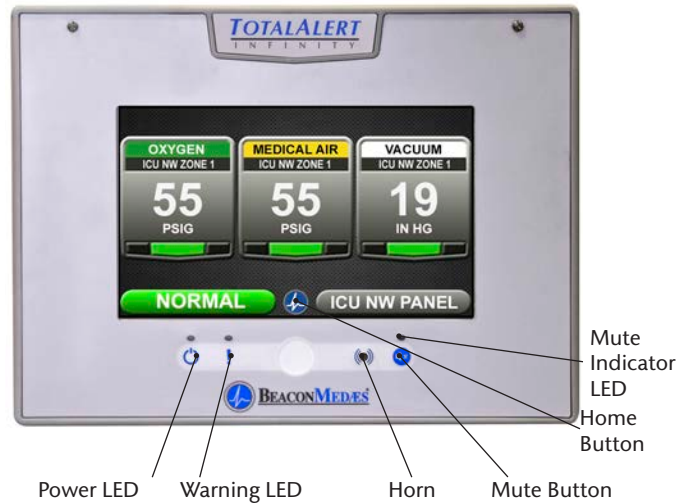

Figure 2: User Interface Layout

1.2.1 TotalAlert Infinity™ Features:

- 10.2" Touch Screen LCD Display.
- User-defined Instructions for Hospital Response Plan
- 10/100base-T Wired Ethernet Connection
- WIFI 802.11 b/g/n interface
- Embedded Web server for viewing alarm information through a computer or tablet
- Electronic Notification of Alarms through e-mail/text messaging
- History Event Log for Documentation
- Electronic User-defined Gas Labels for any mixes
- Electronic User-defined Location Labels
- Ability to “mirror” alarms from other panels using the wired Ethernet interface

1.2.2 Master Alarm

Features:

Monitors up to 60 normally closed dry-contact switch signals wired locally.

- Consolidated view gives easy to read overview of all source equipment status
- Monitors additional source signals from up to 8 remote alarm panels via wired Ethernet connection

1.2.3 Area Alarm

Features:

Monitors up to 8 Digital gas sensors.

- Digital pressure/vacuum read out with Low/Normal/High indicators
- Customizable gas ID labels with user-defined location labels for each monitored gas
- Rough-in box capable of holding 8 locally mounted sensors
- Gas Specific DISS connections for each gas sensor
- Gas Specific Digital ID for each gas sensor

1.2.4 Combination Alarm

Monitors a mix of normally closed dry-contact switch signals, digital gas sensor modules, and 4-20mA transducers.

Features:

- User-defined values for monitoring any 2 or 3 wire 4-20mA transducer

1.2.5 Boards

NOTE:

I	=	4-20mA Inputs
X	=	Source Signal Inputs
Y	=	Dry-Contact Relay Outputs
D	=	Digital Gas Sensor Inputs

B03 Advance Board

Features:

Contains hardware for advanced features of the TotalAlert Infinity™ Alarm.

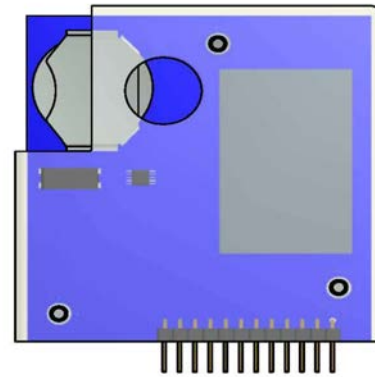

Figure 3: B03 Advanced Board

TotalAlert Infinity™ NFPA Medical Gas Notification System

B05 Power Supply Board

Features:

- Supplies 24VDC to all circuit boards in the alarm.

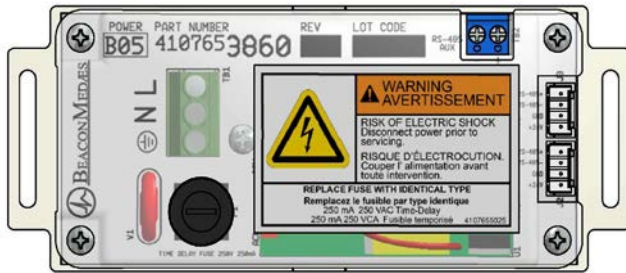

Figure 4: B05 Power Board

B06 Digital Gas Sensor Board

Features:

- Monitors the Pressure/Vacuum from the pipeline, and provides a gas-specific digital signal for the alarm.
- Heartbeat indicator to indicate proper operation.
- Embedded in the gas sensor

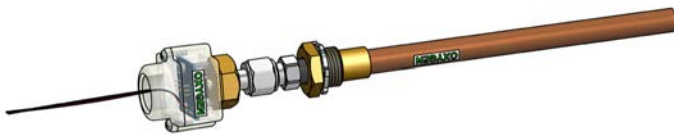

Figure 5: B06 Digital Gas Sensor Board

B10, B11, B12 NFPA Signal Input Board

Features:

- Monitors up to 20 normally closed dry-contact switch signals on each board.
- Heartbeat indicator to signal proper operation.

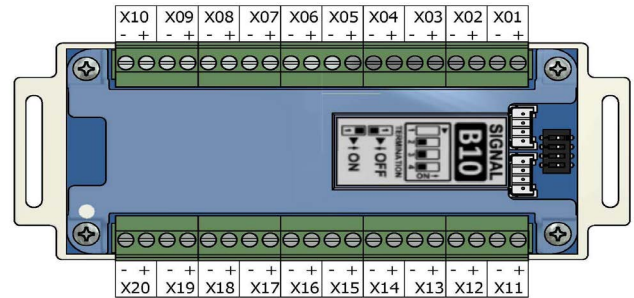

Figure 6: B10, B11, B12 NFPA Signal Input Board

B20 NFPA TA2 Signal Input Board

Features:

- Allows for retrofitting of a TotalAlert² Master alarm with no rewiring necessary.
- Heartbeat indicator to signal proper operation.

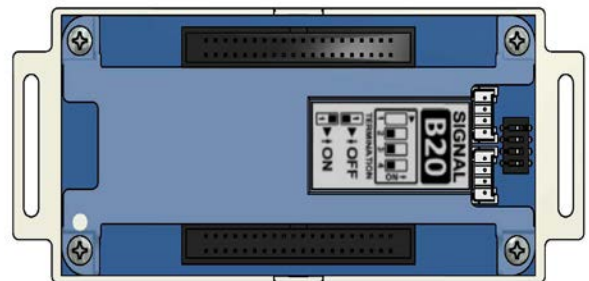

Figure 7: B20 NFPA TotalAlert² Signal Input Board

TotalAlert Infinity™ NFPA Medical Gas Notification System

B40, B41, B42, B43 Relay Output Boards

Features:

- Provides 16 normally closed dry-contact relay outputs for external monitoring.
- Heartbeat indicator to signal proper operation.

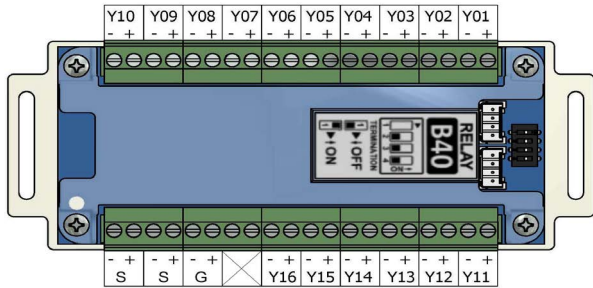

Figure 8: B40, B41, B42, B43 Output Boards

B50 4-20mA Combination Board

Features:

- Monitors up to 4 4-20mA inputs, 7 normally closed dry-contact switch signals, and provides 6 normally closed dry-contact relay outputs for external monitoring.
- Heartbeat indicator signals proper operation.

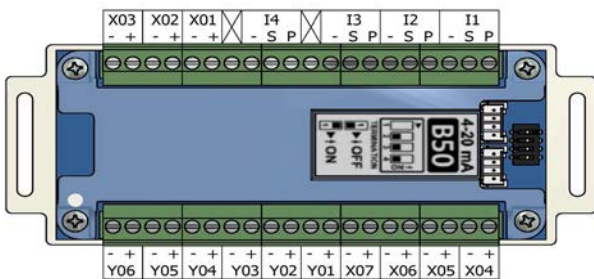

Figure 9: B50 4-20 mA Combination Board

B60 Gas Input Board

Features:

- Monitors up to 8 Digital Gas Sensor Boards. One normally closed dry-contact relay output is available and opens when any fault occurs.
- Heartbeat indicator signals proper operation.

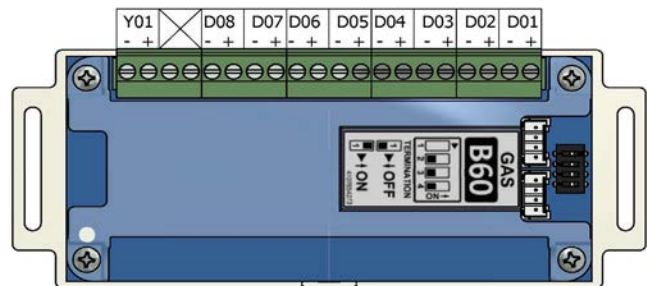

Figure 10: B60 Gas Input Board

B65 Gas Combination Board

Features:

- Monitors up to 3 Digital Gas Sensor Boards and 10 normally closed dry-contact switch signals, and provides 6 normally closed dry-contact relay outputs for external monitoring.
- Heartbeat indicator signals proper operation.

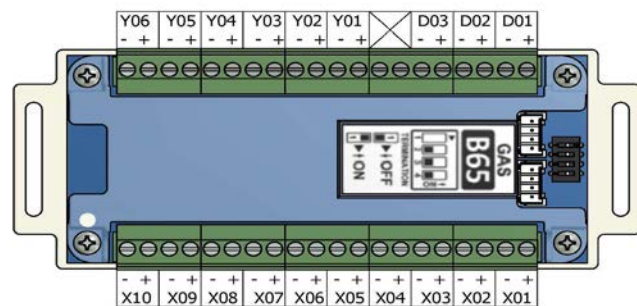

Figure 11: B65 Gas Combination Board

1.3 Definition of Statements

Statements in this manual preceded by the following words are of special significance.



WARNING: Means there is a possibility of injury or death to yourself or others.



CAUTION: Means there is a possibility of damage to unit or other property.



SHOCK HAZARD: Means there is a possibility of electric shock.



ATTENTION: Means precautions for handling electrostatic sensitive devices are to be observed.

NOTE: Indicates points of particular interest for more efficient and convenient operation.

1.4 Definitions

Address Resolution Protocol (ARP)

Protocol used by a device to learn the MAC address of another device so it can send an Ethernet packet.

Area Alarm Panel

Alarm panel that monitors medical gas and vacuum systems serving a specific area.

Combination Alarm Panel

Alarm panel that combines features of a master alarm panel and an area alarm panel.

4-20 mA

Input which monitors a two or three wire 4-20mA transducer.

Crossover Cable

Network cable that swaps transmit and receive pairs so cable can be used to connect two computers or devices without the use of a hub or switch.

Domain Name Server (DNS)

A device that has a list of device names matched to IP addresses. Browsers use this resource to locate the IP address of a named device. NetBIOS name service provides this function on a local network.

Dry-Contact

Electrical contact isolated or unconnected from any electrical source.

Dynamic Host Configuration Protocol (DHCP)

A protocol used by a server to assign IP addresses to devices and computers.

Electromagnetic Compatibility (EMC)

Verification that a product meets required standards for emissions of and immunity from electromagnetic energy in its intended environment.

Ethernet

A standard high-speed network medium specified by IEEE standard 802.3.

TotalAlert Infinity™ NFPA Medical Gas Notification System

Ethernet Switch

A device that connects many Ethernet devices together with optimization. Message destinations are examined and passed only to the correct device.

Firewall

A computer or computer software that prevents unauthorized access to private data from outside computer users.

Gateway

A computer or device that connects two computer networks together (such as a private network and the Internet).

General Fault Relay

Single-pole single-throw dry-contact relay output. Used to activate remote alarm or building management system. Relay will open whenever ANY audible alarm on panel is in progress. General Fault Relay will close only after alarm condition is corrected and alarm panel resumes normal status.

Hyper Text Transfer Protocol (HTTP)

Protocol used to manage the request and transfer of web pages to a computer.

Internet Protocol (IP) Address

Unique number that identifies a device on a network.

LED

Light Emitting Diode

Local Sensors

Pressure / vacuum sensors mounted inside alarm panel back box. Sensor assembly must be piped to medical gas / vacuum pipelines.

Media Access Control (MAC) Address

A unique hardware address of a device on an Ethernet.

Master Alarm Panel

Alarm panel that monitors medical gas and vacuum source equipment and main pipelines.

NetBIOS Name Service

Local method of addressing a device by name. This allows a web browser to reference a device by name instead of an IP address, such as 192.168.2.3.

Remote Sensors

Pressure / vacuum sensors mounted outside of alarm panel back box. Sensor assemblies may be mounted separately or ganged together near pressure / vacuum pipelines. Sensors must then be wired to alarm panel.

Simple Mail Transfer Protocol (SMTP)

Protocol for sending e-mail on a network.

Subnet Mask

A binary number used to separate the network portion from the host portion of a network address.

SMTP Client

Computer or device that uses SMTP to send e-mail by communicating with an SMTP server. The TotalAlert Infinity™ Medical Gas Notification System acts as an SMTP client.

SMTP Server

Computer or device that uses SMTP to receive e-mail from an SMTP client and then transfer it across the internet.

Transmission Control Protocol (TCP)

Protocol used to send data streams between two devices. TCP guarantees reliable and in order data from sender to receiver.

User Datagram Protocol (UDP)

Protocol used to send short messages between computers. UDP does not guarantee reliable transmission (packets may be lost, duplicated or out of order), but is faster and more efficient than TCP.

TotalAlert Infinity™ NFPA Medical Gas Notification System

1.5 Alarm Configurations

All TotalAlert Infinity™ alarm panels are factory pre-configured. Configuration of alarm panel varies dependent upon customer's requirements.

Three types of alarm panels are available.

- Master alarms
- Area alarms
- Combination alarms

1.5.1 Master Alarms

Master alarm panels include the following modular components:

- Signal input boards (B10, B11, B12) that can accept 20 signals per board; maximum of 3 boards.
- Relay boards (B40, B41, B42, B43) that can be used to control 16 dry-contact signals per board; maximum of 4 boards.

Master alarm panels can monitor 20, 40, or 60 switched inputs.

Inputs can be assigned to any gas service indicators.

Model Number Scheme:

____ - _____ - ____ - ____
Series - Configuration - Gas - Retrofit

See Model Number Chart in Section 1.6.

Example:

TotalAlert Infinity™ Master 40X 32Y

Example Model Number: T3-M22



Figure 12: Master Alarm Front Panel

TotalAlert Infinity™ NFPA Medical Gas Notification System

1.5.2 Area Alarms

Area alarm panels include the following modular components:

- Gas Sensor input board (B60) that can be used for up to 8 digital sensors modules
- Digital gas sensor module (B06), can be mounted locally in the rough-in box, remotely on the gas pipeline, or in a compatible BeaconMedæx Zone Valve Box. Maximum of 8 digital gas sensor modules per area alarm panel.

Area alarm panels may be configured for 1 to 8 gas inputs. If alarm is configured with gas inputs, the sensors will be included for connection to pressure/vacuum pipeline.

Sensors may be located inside the alarm rough-in (local sensors) utilizing the DISS inlet tube assemblies provided for brazing to the hospital pipelines.

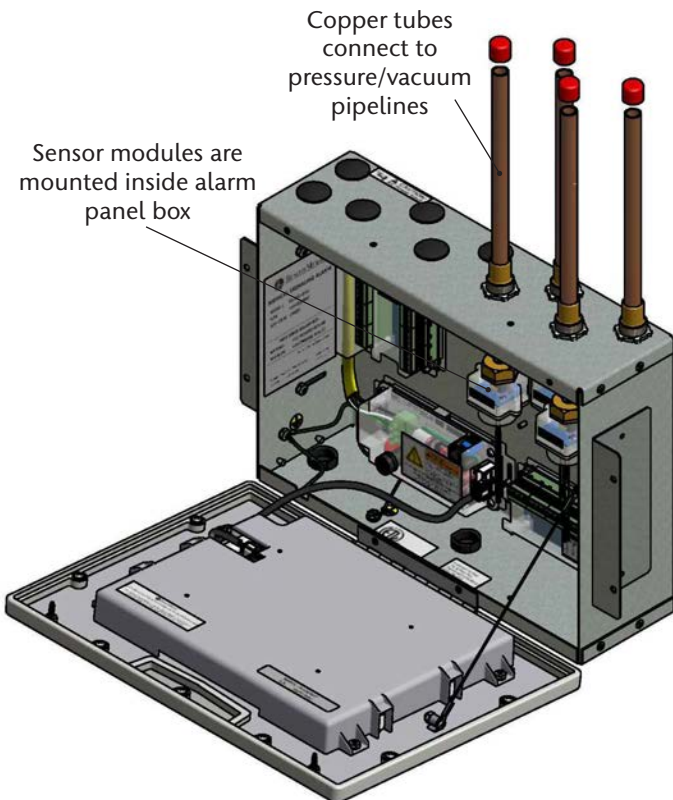

Figure 13: Local Sensors

Sensors may be located outside the alarm rough-in (remote sensors) utilizing the DISS inlet tube assembly or by an 1/4”NPT port.

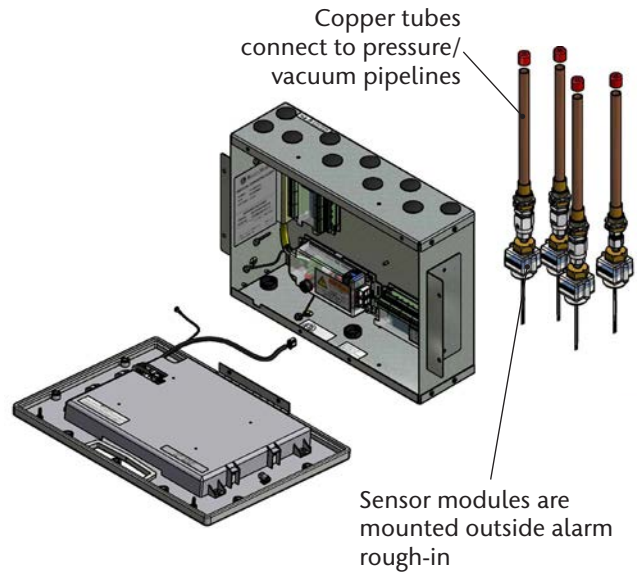

Figure 14: Remote Sensors

Model Number Scheme:

_____ - _____ - ____ - _____

Series - Configuration - Gas - Retrofit

See Model Number Chart in Section 1.6.

Example:

TotalAlert Infinity™ Area Alarm OAV
Example Model Number: T3-A10-OAV



Figure 15: Area Alarm Front Panel

TotalAlert Infinity™ NFPA Medical Gas Notification System

1.5.3 Gas Combination Alarms

Gas Combination alarms include a mix of the following modular components:

- B1X board
- B60 board
- B65 board
- B4X board
- B50 board

Combination alarms can monitor up to 60 locally wired switched inputs.

Inputs can be assigned to any one of 10 gas service indicators.

Optional dry contact relays are available.

Combination alarms can also monitor up to 6 digital gas sensors.

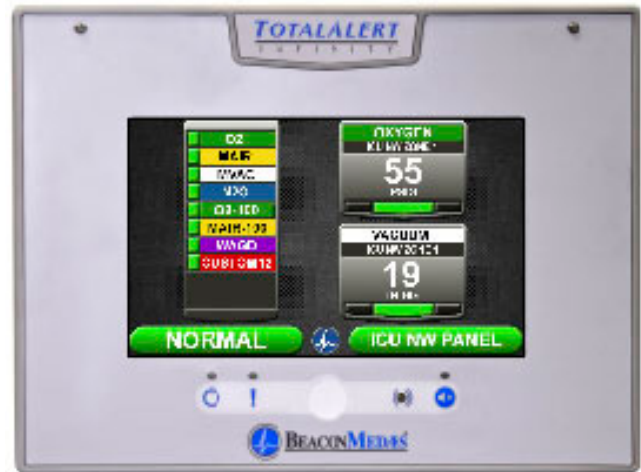

Figure 16: Combination Alarm Front Panel

Model Number Scheme:

_____ - _____ - ____ - _____

Series - Configuration - Gas - Retrofit

See Model Number Chart in Section 1.6.

Example:

TotalAlert Infinity™ Combination

Example Model Number: T3-C21-OAVX

TotalAlert Infinity™ NFPA Medical Gas Notification System

1.6 TotalAlert Infinity™ Medical Gas Notification System Parent Model Number Chart

$$T3 - \frac{\quad}{B} - \frac{\quad}{C}$$

Variable B Alarm Type and Size	
Allowable Value	Description
A10	Area Alarm, Up to 8 Area Gases
M01	Master, 0 Inputs, 16 Relay Outputs
M10	Master, 20 Inputs
M11	Master, 20 Inputs, 16 Relay Outputs
M12	Master, 20 Inputs, 32 Relay Outputs
M13	Master, 20 Inputs, 48 Relay Outputs
M20	Master, 40 Inputs
M21	Master, 40 Inputs, 16 Relay Outputs
M22	Master, 40 Inputs, 32 Relay Outputs
M30	Master, 60 Inputs, 0 Relay Outputs
M31	Master, 60 Inputs, 16 Relay Outputs
C01	Combination, 10 Inputs, 6 Relay Outputs, Up to 3 Area Gases
C10	Combination, 20 Inputs, Display up to 6 Area Gases
C11	Combination, 20 Inputs, 16 Relay Outputs, Display up to 6 Area Gases
C12	Combination, 20 Inputs, 32 Relay Outputs, Display up to 6 Area Gases
C20	Combination, 40 Inputs, Display up to 6 Area Gases
C21	Combination, 40 Inputs, 16 Relay Outputs, Display up to 6 Area Gases
C30	Combination, 60 Inputs, Display up to 6 Area Gases
C40	Combination, 7 Inputs, 6 Relay Outputs, 4 Inputs for 4-20mA devices
C41	Combination, 27 Inputs, 6 Relay Outputs, 4 Inputs for 4-20mA devices
C42	Combination, 47 Inputs, 6 Relay Outputs, 4 Inputs for 4-20mA devices
C43	Combination, 67 Inputs, 6 Relay Outputs, 4 Inputs for 4-20mA devices
C44	Combination, 7 Inputs, 6 Relay Outputs, 4 Inputs for 4-20mA devices, Up to 6 Area Gases (maximum display of 6 gas badges, in combination of 4-20mA and gas sensors)

NOTE: For Area Alarm panels, sensor assemblies are not specific to "Remote" or "Local" installations. It is not necessary to designate the installation type in the model numbering.

Variable C Gas Type (Area and Combination Only)	
Allowable Value	Description
O	Oxygen
X	Nitrous Oxide
A	Medical Air
V	Medical Vacuum
W	WAGD
N	Nitrogen
C	Carbon Dioxide (CO2)
D	Oxygen 100 psig
F	Medical Air 100 psig
G	Carbon Dioxide 100 psig
9	Instrument Air
1	CO2-O2 (CO2 over 7%)
2	O2-CO2 (CO2 not over 7%)
3	HE-O2 (HE over 80%)
4	O2-HE (HE not over 80%)
7	Laboratory Air
8	Laboratory Vacuum
H	Helium
J	Argon
S	Surgical Air
B	AGSS
E	N2O-O2
M	Mixed Gas

Example: TotalAlert Infinity™ Master Alarm with 40 Inputs and 32 Relay Outputs

Example Model Number: [T3-M22](#)

Example: TotalAlert Infinity™ AREA Alarm with 4 gases - Oxygen, Nitrous Oxide, Medical Air, and Vacuum

Example Model Number: [T3-A10-OXAV](#)

Example: Combination Alarm with 10 Inputs, 6 Relay Outputs, and 3 gases - Oxygen, Medical Air, and Medical Vacuum

Example Model Number: [T3-C01-OAV](#)

Example: Combination Alarm with 7 Inputs, 6 Relay Outputs, 4 4-20mA devices, and 2 gases - Oxygen, Medical Air

Example Model Number: [T3-C44-OA](#)

NOTE:

Standard configurations listed above. For special configurations contact BeaconMed-aes Customer Service (888) 463-3427.

2.0 Installation Procedures

2.1 Alarm Panel Rough-In Box

The rough-in box can be installed between 16" on center standard studs. Mounting ears on either side of the rough-in box are provided for attachment to studs, with depth adjustment to accommodate different thicknesses of wall board.

Knock out plugs are provided in the top and bottom of the box for routing of supply power, Ethernet CAT5 cable, gas sensor tubes or other necessary wiring.

DO NOT drill rough-in box.

1. Prepare rough wall opening large enough to accommodate alarm rough-in box.

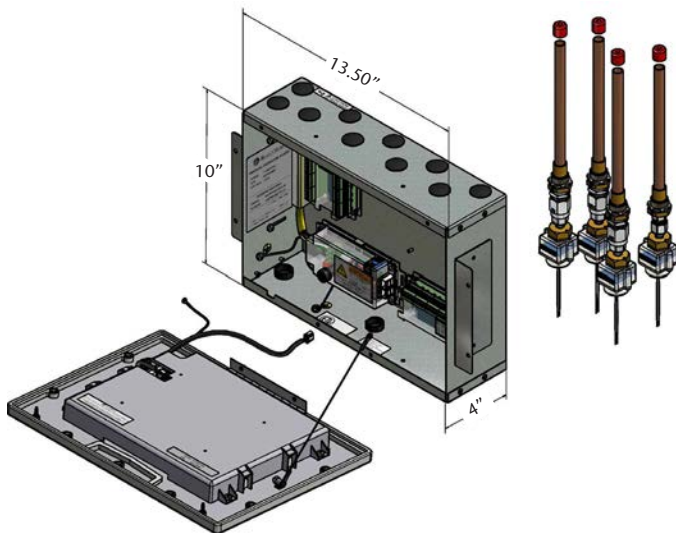

Figure 17: Alarm Panel Rough-In Box Dimensions

Alarm rough-in box must have rigid vertical members for support on both left and right sides. Power to alarm panel shall enter through bottom left or top left conduit hole in rough-in box.

2. Remove cardboard dust cover and DISS tube assemblies (if included) and insert alarm rough-in box into wall opening. Secure with fasteners suitable for vertical supports (Figure 18).
3. Mounting brackets on each side of rough-in box are adjustable and factory preset for 5/8" thick drywall. After drywall installation, front edge of rough-in box should be flush with finished surface of wall. If needed, make any necessary bracket adjustments at this time (Figure 18).
4. Reinstall cardboard dust cover to prevent dust and debris from entering the rough-in box.

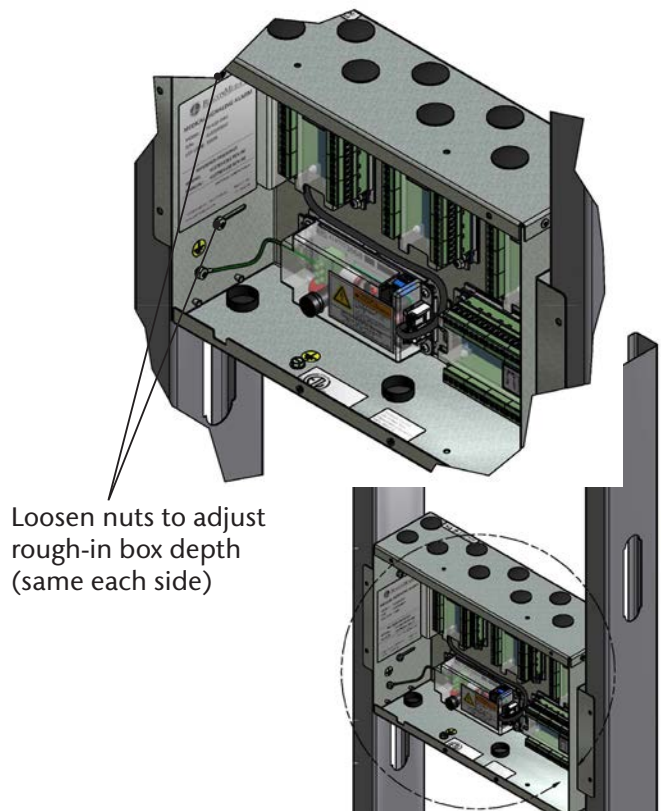

Figure 18: Mounting Bracket Adjustment

2.2 Gas Sensor Installation

2.2.1 Locally Installed Sensors

1. Locate copper adapter tube(s) packaged inside the alarm rough-in box.
2. Install tube(s) into the top of the rough-in box through the holes provided. Notice the Gas ID labels and position appropriately for connection to the hospital piping. **Apply Gas ID label provided with tube adapter to the inside of the rough-in box to identify the ports after walls are closed in.**
3. Braze copper adapter tube(s) to appropriate pressure/vacuum piping system drops (Figure 19). Braze connections per procedures required by NFPA 99 or CAN/CSA-Z7396.1-12. Use appropriate measures to prevent overheating.
4. Install the Gas Specific DISS check valve into the appropriate tube adapter.
5. Perform standing pressure test and cross connection tests as required by NFPA and CSA.

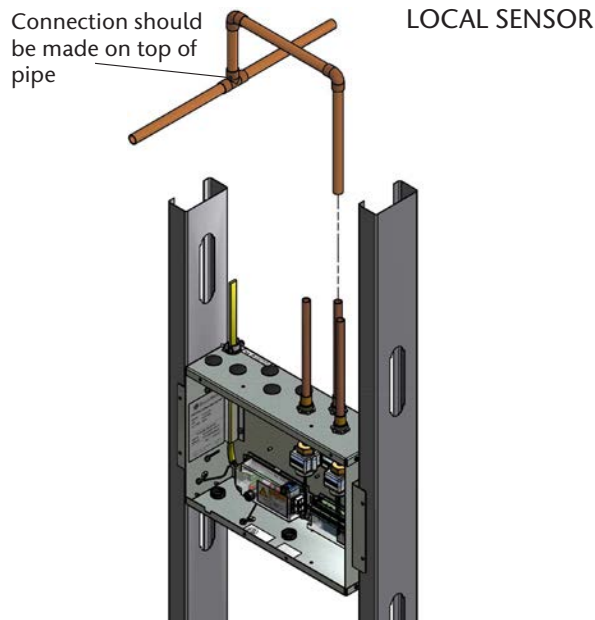

Figure 19: Sensor Pipeline Connection

2.2.2 Remotely Installed Sensors in Pipeline

1. Sensors can be installed onto the hospital pipeline.
2. Braze copper adapter tube(s) to appropriate pressure/vacuum piping system connections (Figure 20).
3. Braze connections per procedures required by NFPA 99 or CAN/CSA-Z7396.1-12
4. Use appropriate measures to prevent overheating.
5. Install the Gas Specific DISS check valve into the appropriate tube adapter.
6. Perform standing pressure test and cross connection tests as required by NFPA and CSA.

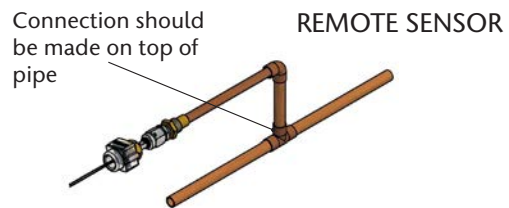

Figure 20: Remote Pipeline Installation

2.2.3 Remotely Installed Sensors in Zone Valve Box

1. Remote sensors can be installed in a compatible BeaconMedæx Zone Valve Box. (NOTE: copper adapter tube not needed for Zone Valve box installation (Figure 21).
2. For Zone Valve Box mounting, an additional Installation Kit is required, part number 4107 4016 25 for each sensor.

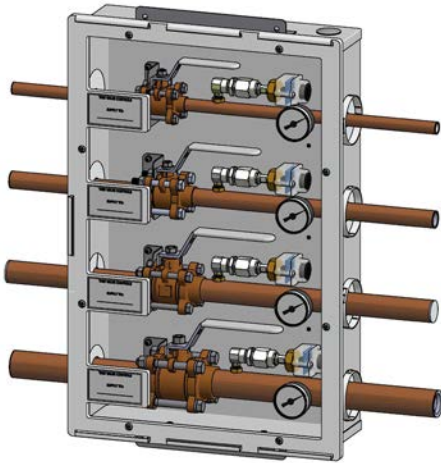

Figure 21: Zone Valve Box Location

2.3 Wiring

2.3.1 General Requirements

1. All alarms are to be powered from life safety branch of emergency power system as required by applicable standards.
2. Protect all wiring from physical damage by raceways or conduit as required by applicable standards.
3. Wire alarm panels directly to switches or sensors as required by applicable standards.
4. Wiring runs should be made with color coded wire. Record color, signal, and source of signal for each wiring lead to aid in connection of alarm finish components.
5. Avoid installing alarm panels near radio transmitters, electrical motors, or switch-gear.

2.3.2 Wire Type and Size

All low voltage wiring must meet the following criteria:

- Copper wire no smaller than 22 AWG, conductor insulation at least 0.010in (0.25mm), jacket insulation at least 0.030in (0.76mm), rated for 300V and 60°C (140°F) minimum.

- Circuit length not to exceed 5000 feet.
- Cable must be twisted-pair shielded type. Multi-pair cables within one common shield are acceptable.

2.3.3 Determining Number of Conductors

The following rules along with references to this manual's schematics clarify wiring requirements.

- **Digital Gas Sensor Modules**

Two conductor cables (must be twisted pair type with shield) are required for each Gas Sensor module to the Gas Input board (B60 or B65).

Refer to **NFPA Area Wiring Diagram (Section 3.2)**

- **Switched signal inputs**

Two conductor cables (must be twisted pair type with shield) are required for each signal between the signal input terminals and the source signal switch.

These signals can originate at source equipment or from pressure switches mounted on main pressure / vacuum pipelines.

When two master alarms are required, the same switch / relay contacts can be wired to both alarm panels. (See CAUTION below).

Both pairs of wires should originate from switch/relay contacts.

Refer to **NFPA Master/Combination Wiring Diagram (Section 3.1/3.3)** for B1X, B50, B65 signal boards.

CAUTION:

Do not connect TotalAlert Infinity™ master/combination alarm to switch/relay contacts connected to any alarm panels other than those listed below:

- TotalAlert Infinity™
- TotalAlert2
- MEGA3
- MEGA2
- MEGA

• Relay outputs

Two conductors are required for each signal between relay output terminals and remote device (such as a building automation system). Refer to the wiring requirements of the connecting device when selecting the appropriate type of conductors to use (i.e. wire gauge, twisted or not, shielded or not.)

Refer to **NFPA Master/Combination Wiring Diagram (Section 3.1/3.3)** for B4X, B50, B65 signal boards.

• Digital display module “mirroring”

Two panels may be connected together so digital display module pressure reading(s) of first panel will be duplicated at second panel.

An eight conductor category 5 CROSS OVER cable is required for connecting alarm panels directly to each other. Otherwise, standard cabling can be used with a facility’s Ethernet hub or switch to set up a connection between panels.

• Ethernet

For each alarm panel to be networked, an eight conductor category 5 network cable is required between each alarm panel and a facility’s Ethernet hub or switch.

2.3.4 Power Supply

A power supply assembly is provided with the alarm panel. The installer must use 18AWG copper supply wiring minimum with an insulation of not less than 1/32 inch (0.8mm) thick. Power supply shall be connected to a building installed circuit breaker. Circuit breaker shall be a maximum of 15 amps and marked as disconnecting means for the alarm panel. It is recommended that the circuit breaker be in close proximity to the alarm panel and properly selected according to local and national regulations.

Holes are provided in the top and bottom of the rough-in box for main power (Figure 22). Wiring is to be installed under the provisions of the National Electric Code, NFPA 70.

If power is entering from the top, it must be routed under the cable raceway.

NO OTHER HOLES SHOULD BE PUNCHED OR USED.

Several additional holes or knockouts are provided on the top panel and bottom for entrance of low voltage field wiring (Figure 22).

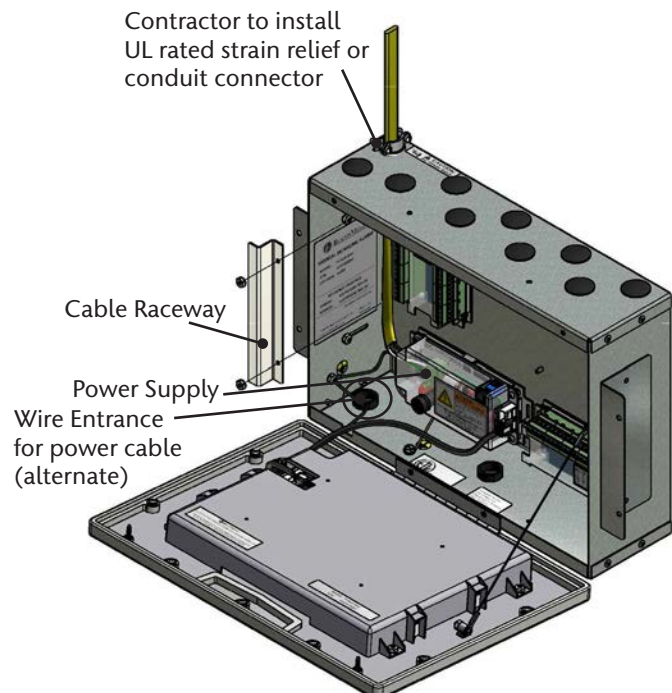

Figure 22: Wire Routing

TotalAlert Infinity™ NFPA Medical Gas Notification System

NOTE:

All wiring shall be protected from physical damage by raceways or conduit in accordance with NFPA 70, National Electric Code.

Alarm panels require 100 to 250 VAC 50/60 Hz 250mA power. **NFPA Area Wiring Diagram (Section 3.2)**

For NFPA 99 compliance, alarm panel must be connected to life safety branch of the emergency electrical system.

1. Remove four screws from plastic power supply shield.
2. Remove plastic shield from power supply.
3. Connect incoming line and neutral wires to the terminal block. Ground wire connects directly to the rough-in box (chassis) at the green screw below the power supply (Figure 23).
4. DO NOT remove or alter the Green factory installed ground wire from the terminal block to chassis.
5. Reinstall plastic power supply shield while making sure all high voltage wires are contained within plastic shield.
6. Secure plastic shield with four screws.

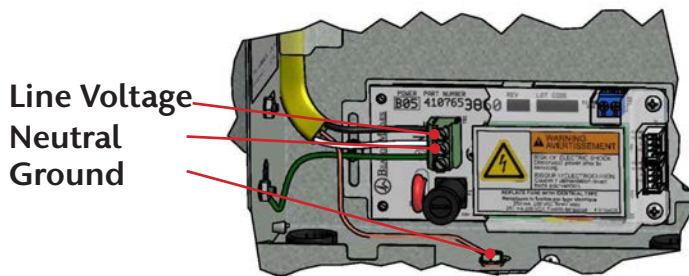

Figure 23: Supply Power Wiring



WARNING:



RISK OF ELECTRICK SHOCK

Disconnect power at the circuit breaker before removing power supply shield.

2.3.5 B60 Gas Input Board

An Area alarm has 8 Gas Inputs. Signals are numbered D01 thru D08. There is a single relay output for general gas fault notification.

1. Identify each pair of twisted gas sensor wires inside the alarm rough-in box (Figure 24).
2. Route each pair of sensor wires as shown (Figure 25) to appropriate terminals.
3. Connect each pair of sensor wires to terminal blocks noting the correct polarity Red(+), Black (-). **NFPA Area Wiring Diagram (Section 3.2)**

NOTE:

If gas sensor wires are landed on the terminal blocks in the same order as defined by the model number of the alarm panel, then initial setup will be easier and gas sensor channels will not need to be reconfigured." Example T3-A10-OAV means "O" Oxygen is defaulted to D01, "A" Medical Air is defaulted to D02, etc. See section 1.6.

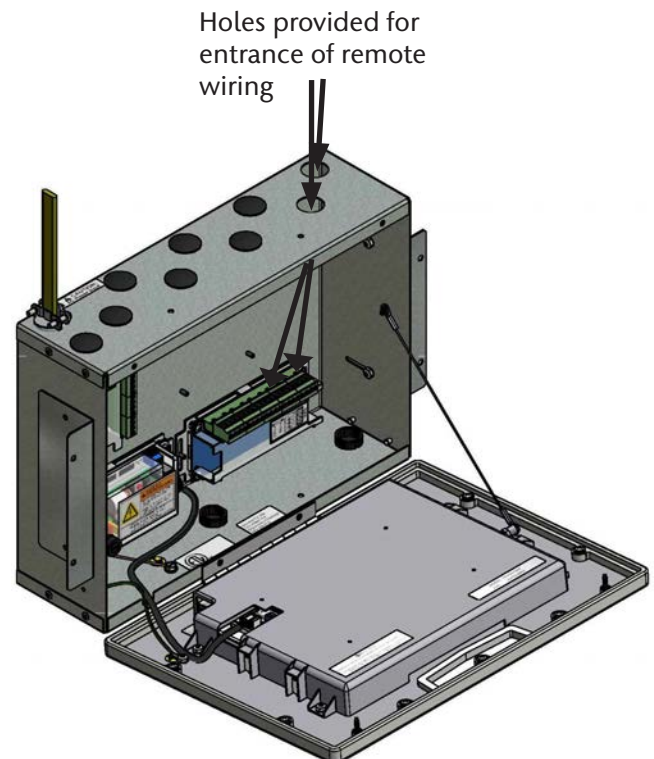

Figure 24: Remote Sensor Wire Routing

TotalAlert Infinity™ NFPA Medical Gas Notification System

CAUTION:

Do not connect TotalAlert Infinity™ master/combination alarm to switch/relay contacts connected to any alarm panels other than those listed below:

- TotalAlert Infinity™
- TotalAlert2
- MEGA3
- MEGA2
- MEGA

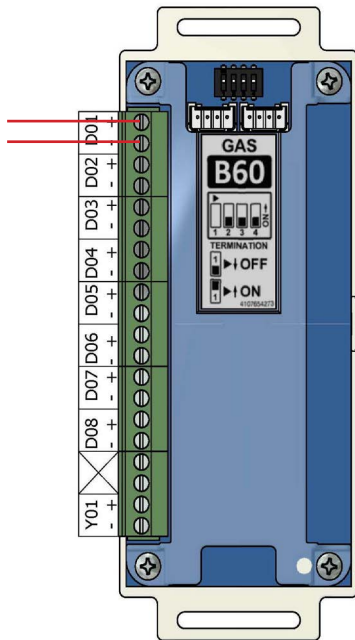

Figure 25: B60 Board Wire Routing

2.3.6 B1X Signal Board

A Master or Combination alarm panel can contain multiple signal input boards; up to a maximum of 3 boards or 60 signal inputs.

Input signals on B10, B11, B12 boards are labeled X01 thru X20.

Identify each twisted pair of field installed signal input signal wires inside the alarm rough-in box.

Route each pair of signal input signal wires as shown in Figure 26 to appropriate terminals on input board(s).

Connect each pair of signal wires to terminal blocks noting the correct polarity (+,-). Refer to **NFPA Master/Combination Wiring Diagram (Section 3.1/3.3)**.

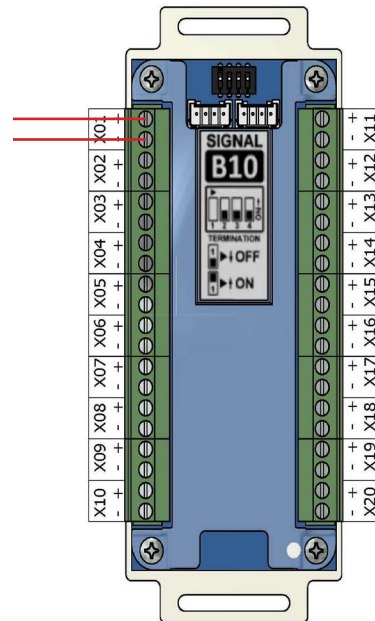

Figure 26: B1X Signal Board Wire Routing

CAUTION:

Source equipment signal wires must be connected to normally-closed, dry contacts. No electrical voltage can be present and contacts must be closed during normal equipment operation. When contacts open, an alarm condition will be activated.

NOTE:

Each pair of terminals labeled on the signal board connector is labeled “+” and “-”. Ensure that when a source equipment dry contact is wired to two master panels, the same side of the dry contact is connected to the same terminal at both panels. For example, if the source equipment’s normally closed contact is wired to the “+” of the first master panel, ensure it is also connected to the “+” terminal of the second master panel.

2.3.7 B4X Relay Output Board

A Master or Combination alarm can contain multiple relay output boards; up to a maximum of 4 boards with 16 relay outputs each. The B4X boards (B40, B41, B42, B43) utilize normally closed dry contact relay outputs. The outputs on the B4X boards are labeled Y01 through Y16.

Identify each pair of field installed relay output signal wires inside the alarm rough-in box. Route each pair of relay output wires as shown in Figure 27 to the appropriate terminals on the relay board. Connect each pair of signal wires to the terminal blocks, noting the correct polarity (+,-). Refer to NFPA Master/Combination Wiring Diagram (Section 3.1/3.3).

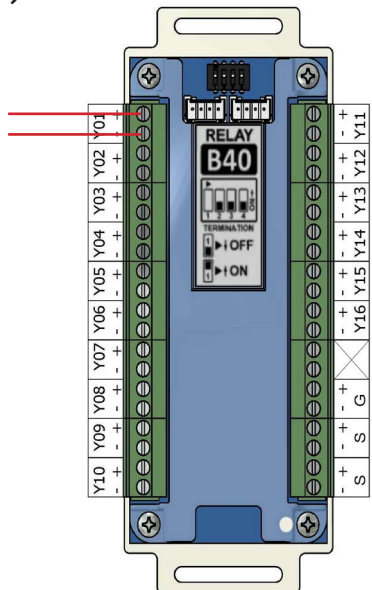

Figure 27: B4X Board Wire Routing

2.3.8 B50 4-20mA Combination Board

A Combination alarm can contain a B50 board that contains four 4-20mA inputs that can be used with a 2 or 3 wire transmitter. The board also contains seven signal inputs, which monitor normally closed signal inputs, and six normally closed dry contact relay outputs. Each alarm panel can have a maximum of one B50 board.

Identify each set of field installed 4-20mA input signal wires (2 or 3 wires per set) inside the alarm rough-in box. Route each set of input wires to the appropriate terminals on the B50 board. Connect each set of signal wires to the terminal blocks, noting the correct polarity (Figure 28).

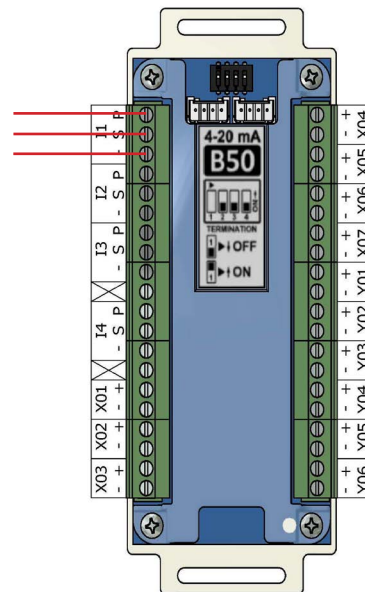

Figure 28: B50 Board Wire Routing

2.3.9 Alarm Panel “Mirroring”

Each alarm panel has an Ethernet port on the back of the front panel assembly. By connecting the alarm to the hospital network, via Ethernet, or directly cabling it to another alarm panel, signals and gas pressures can be pulled from one panel and displayed on another panel.

A category 5 CROSS OVER cable is required for connecting alarm panels directly to each other. Otherwise, standard cabling can be used with a facility’s Ethernet hub or switch to connect panels.

2.3.10 General Fault Relay

The B60 Gas Input board is supplied with an alarm panel general fault output relay.

This relay has a set of dry contacts that is wired normally closed.

The relay will activate when ANY alarm on the ENTIRE alarm panel is activated. Relay will remain activated as long as alarm condition is active, even if audible alarm is silenced by MUTE button.

When alarm condition is corrected, relay will deactivate. Relay contact ratings are 5A @ 30VDC / 3A @ 250VAC. Refer to NFPA Area Wiring Diagram (Section 3.2).

2.3.11 Ethernet

Alarms can be connected to a facility’s network via Ethernet by plugging the network cable to the port provided on the back of the alarm front panel.

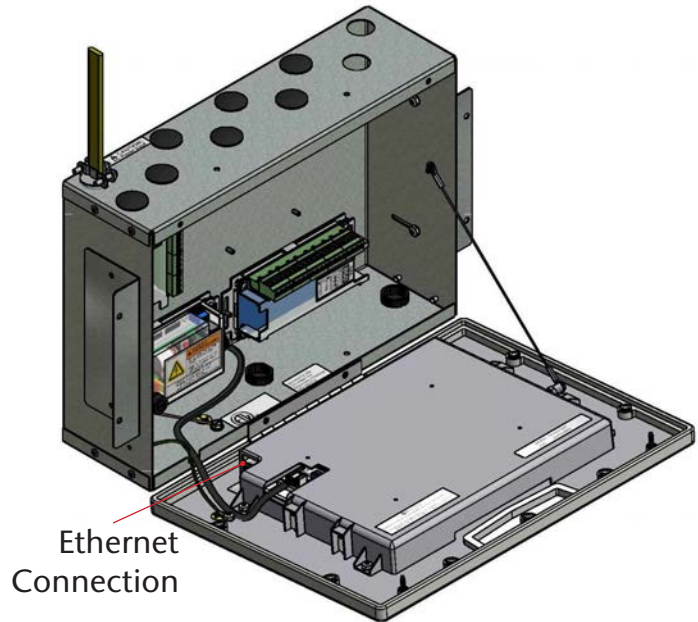

Figure 29: Ethernet Connection

2.3.12 Field Wiring Cable Shield Grounding

All field wiring cable shields must be grounded inside alarm panel back box.

Holes are provided in the top and bottom of the alarm rough-in box for grounding screws (Figure 30).

Shields from several cables may be wrapped together and crimped into one screw (by others).

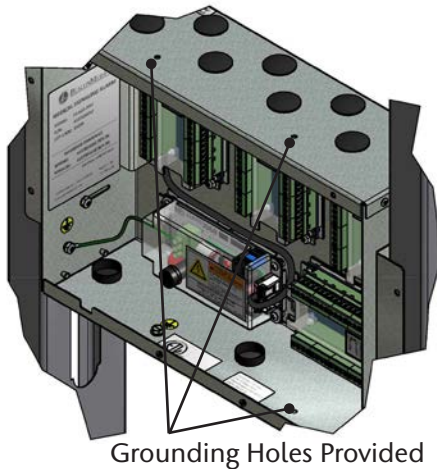

Figure 30: Cable Shield Grounding-Area

CAUTION:

Keep shield wires to ground screw as short as possible so they can not touch front panel circuit boards when front panel is closed.

2.3.13 BACnet

The BeaconMedæ's TotalAlert Infinity™ NFPA control systems utilize the TCP/ IP family of protocols for communication and each alarm has a unique IP address.

Each BACnet enabled TotalAlert Infinity™ alarm conforms to the BACnet protocol.

- **Protocol Implementation Conformance Statement**

Each BACnet enabled TotalAlert Infinity™ alarm has available a Protocol Implementation Conformance Statement (PICS). The PICS is a written document created by BeaconMedæ's that identifies the particular options specified by BACnet that are implemented in the TotalAlert Infinity™ alarm.

- **BACnet Conformance**

BACnet Vendor ID: 543

Alarm Profile: BACnet Smart Sensor (B-SS)
BIBB (BACnet Interoperability Building Blocks)

Supported:

- Read Property - B (DS-RP-B)
- Dynamic Device Binding - B (DM-DDB-B)
- Dynamic Object Binding - B (DM-DOB-B)

Object Type Support: Analog value, Binary value, Device.

Data Line Layer Options: ISO 8802-3 ("Ethernet") LAN

Character Set Support: ISO 10646 (UTF-8) Encoding

2.4 Finish Assembly

2.4.1 Front Panel Mounting



ATTENTION:
Observe Precautions for Handling
ELECTROSTATIC SENSITIVE DEVICES

1. Remove front panel assembly from packaging.
2. Remove front panel mounting screws from alarm panel rough-in box assembly (Figure 31).
3. Remove lanyard mounting nut from alarm panel back box assembly (Figure 31).
4. Attach front panel to alarm panel rough-in box using screws removed in step 2 (Figure 32).
5. Attach lanyard to alarm panel rough-in box using screws removed in step 3 (Figure 32).
6. Remove nut from front panel grounding lug.
7. Install front panel grounding wire using nut removed in step 6.
8. Connect the grey cable on the front panel to the open power/communication port on the power supply.

NOTE:

Harness connector is keyed to prevent incorrect orientation. However, use care to ensure correct pin alignment.

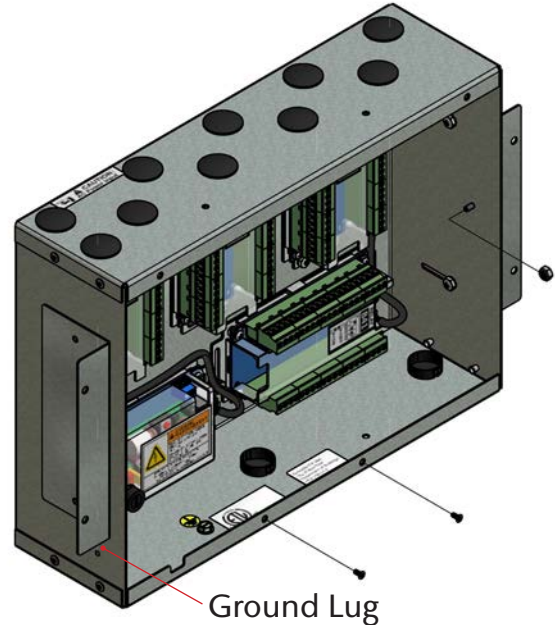

Figure 31: Front Panel Screws

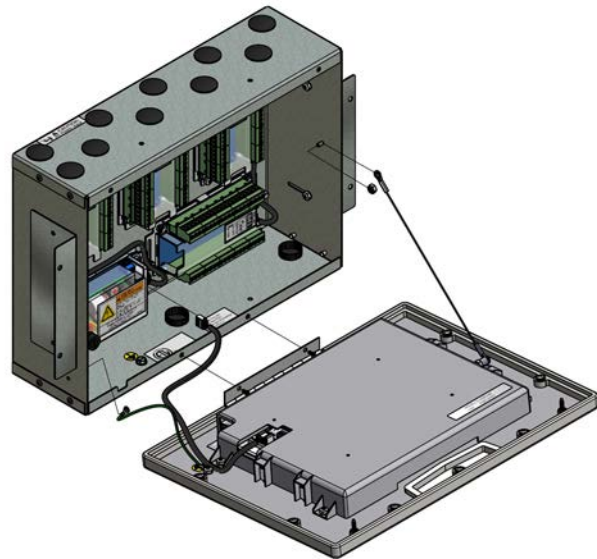

Figure 32: Attach Front Panel and Lanyard

TotalAlert Infinity™ NFPA Medical Gas Notification System

2.4.2 Locally Installed Sensors

1. Remove sensor module from shipping carton.
2. Connect sensor with DISS fitting to the appropriate DISS check at the top of the rough-in box. Verify Gas ID labels match between the sensor and piping to ensure no cross connections occur. Repeat this process for all sensors within alarm panel.
3. Connect wires into input terminals of B60 board (see section 2.3.5).

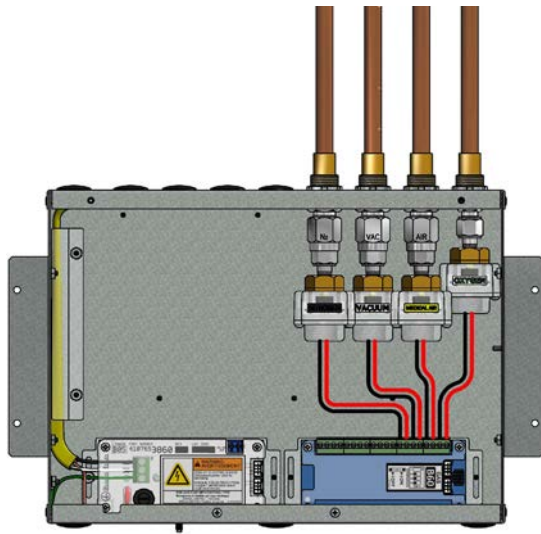

Figure 33: Local Sensor Mounting

NOTE:

If gas sensor wires are landed on the terminal blocks in the same order as defined by the model number of the alarm panel, then initial setup will be easier and gas sensor channels will not need to be reconfigured.” Example T3-A10-OAV means “O” Oxygen is defaulted to D01, “A” Medical Air is defaulted to D02, etc. See Section 1.6.

2.4.3 Remotely Installed Sensors in Pipeline

1. Remove sensor from shipping carton.
2. Connect sensor with DISS fitting to the appropriate DISS Check on the hospital pipeline or BeaconMedæx Zone Valve box. Verify Gas ID labels match between the sensor and piping to ensure no cross connections occur.
3. Wire nut pigtail to field installed wiring. Note polarity of wiring and corresponding field wiring color or number for later (see section 2.3.5).

NOTE:

Do not ground shield drain wire at sensor.

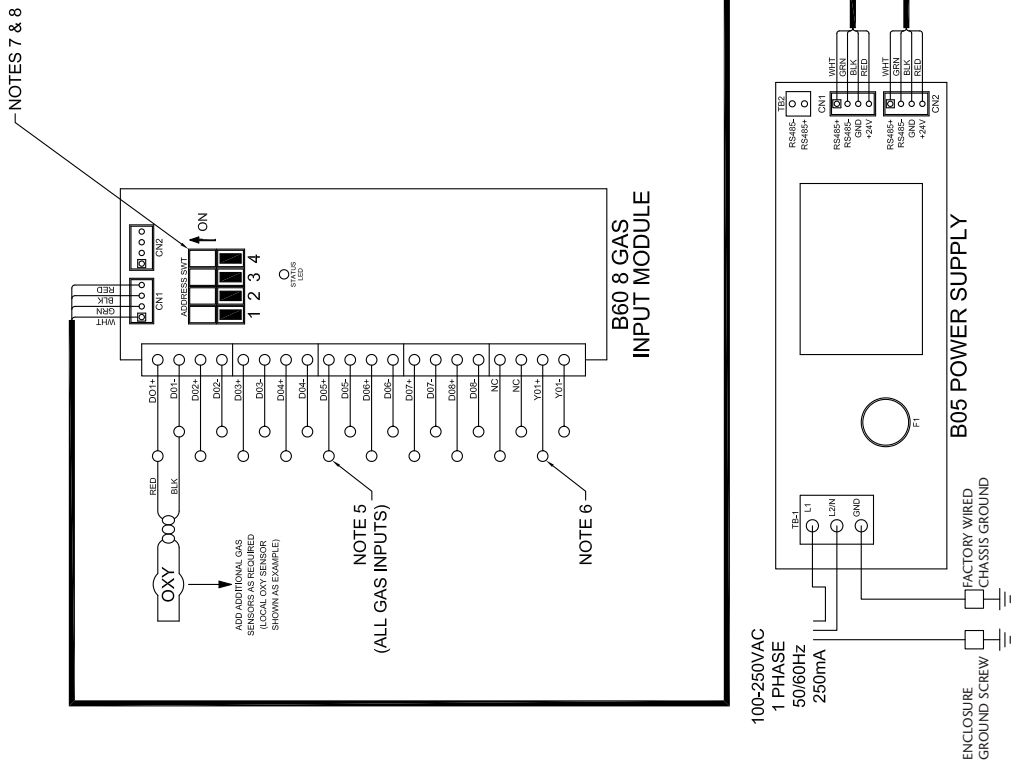

Figure 34: Remote Sensor Module Connection

TotalAlert Infinity™ NFPA Medical Gas Notification System

3.2 NFPA Area Wiring Diagram

- Notes:
1. MAIN DISCONNECT PROVIDED BY OTHERS
 2. FIELD POWER WIRING TO BE COPPER RATED FOR 75°C MINIMUM
 3. FIELD SIGNAL WIRING TO BE MINIMUM .22AWG
 3. MULTI-CONDUCTOR CABLE MUST BE TWISTED PAIR TYPE WITH SHIELD
 3. TOTAL CIRCUIT LENGTH NOT TO EXCEED 10,000' & MAX. 1K OHM RESISTANCE
 4. --- INDICATES FIELD WIRING OUTSIDE OF BOX.
 5. SIGNAL INPUTS FROM GAS SENSOR MODULES
 6. RELAY OUTPUT CONTACT RATED 3A / 30VDC MAX.
 7. SEE MODULE LABEL TO SET MODULE ADDRESS (POSITIONS 2,3, & 4). VERIFY USING TABLE 1.
 8. SET ADDRESS SWT POSITION 1 TO "ON" FOR LAST MODULE IN CHAIN ONLY.



MODULE ADDRESS SWITCH SETTINGS

B60 MODULE SWT			
1	2	3	4
NOT	off	off	off
B60	∞	off	off

TABLE 1

Figure 36: Wiring Diagram for TotalAlert Infinity™ Area Alarm

TotalAlert Infinity™ NFPA Medical Gas Notification System

3.3 NFPA Combination Wiring Diagram

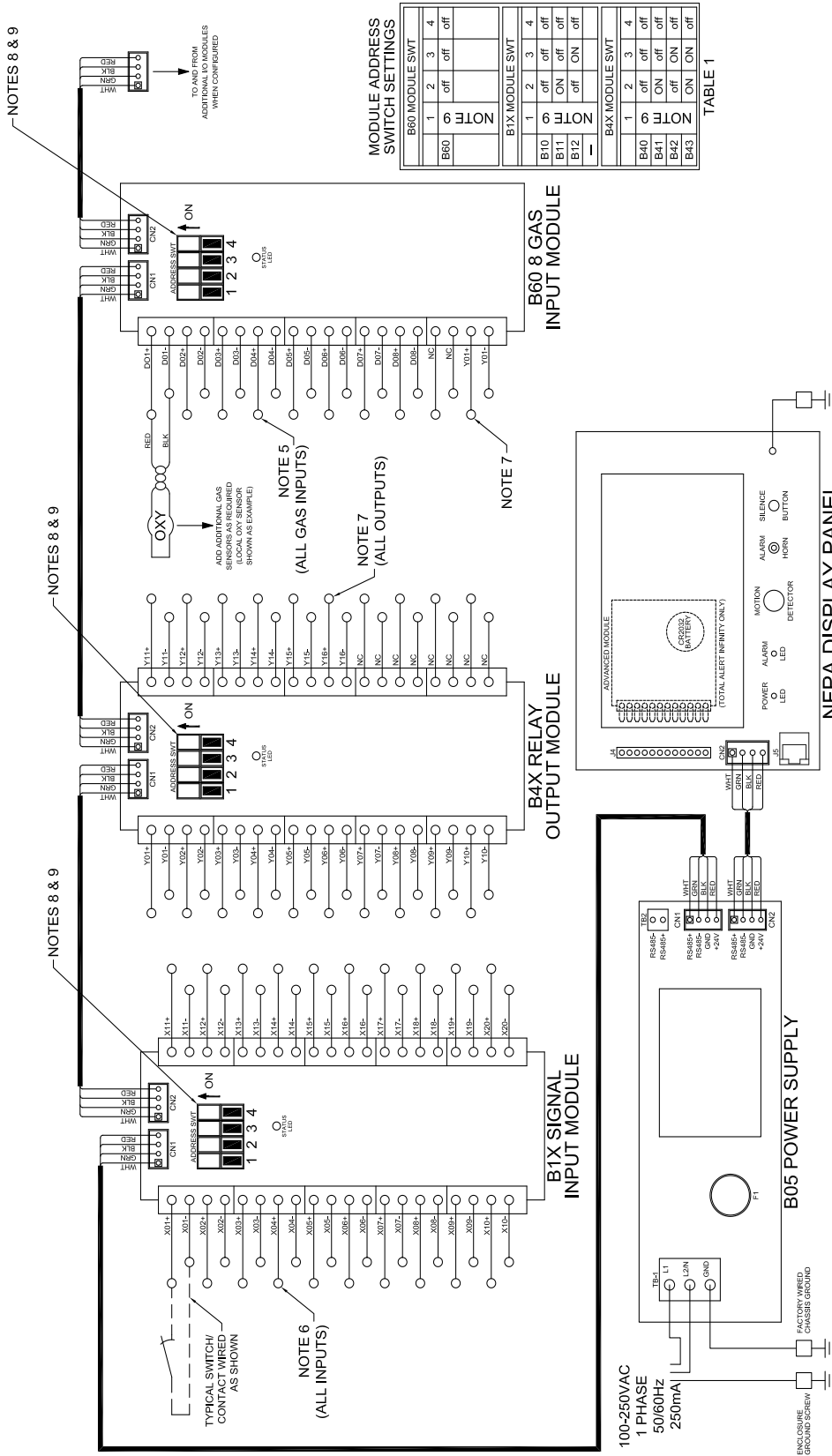

Figure 37: Wiring Diagram for TotalAlert Infinity™ Combination Alarm

4.0 Operation

4.1 Overview

The TotalAlert Infinity™ Medical Gas Notification System is a touchscreen gas pressure and system monitoring alarm created for ease of use.

For convenience, it is shipped from the factory as a configured unit.



Figure 38: User Interface

4.1.1 Main Screen

The first screen that users see on a configured unit is the MAIN screen. The MAIN screen is the main view for the alarm and shows the pressure status of all of the gases or source signals the alarm is monitoring.

NOTE:

The main screen will appear different depending on whether the alarm panel is configured as an area, master or combination.

An area alarm main screen will show gas pressure badges, a master alarm main screen will show source badges, and a combination alarm main screen will show both gas badges and source badges.

4.1.2 Gas Badge

Every gas monitored by the alarm will have a gas badge which will show the following information:

- Gas being monitored
- Location where gas is being used
- Gas pressure value
- Gas pressure status (Low, Normal, or High)



Figure 39: Gas Badge

4.1.3 Source Signals

Every source signal monitored by the alarm will display the following information once configured:

- Equipment being monitored
- Location of the source equipment
- Signal being monitored
- Source signal status Red (open - in alarm) or Green (closed - normal)

Each source badge can show the status of up to 8 signals.



Figure 40: Source Badge

4.1.4 TotalAlert Infinity™ Consolidated Badge

Features:

- A Combination alarm contains up to 10 Gas Service Indicators on the main screen.
- Gas Service Indicators can represent up to 20 Source Badges of the same gas service.
- Up to 12 Consolidated Master Badges can be assigned on a Master Alarm main screen.
- Consolidated Master Badge contains a single Gas Service Indicator for normal (green) or abnormal (red) condition.



Figure 41: TotalAlert Infinity™ Combination Consolidated Badge



Figure 42: Master Alarm Consolidated Badge

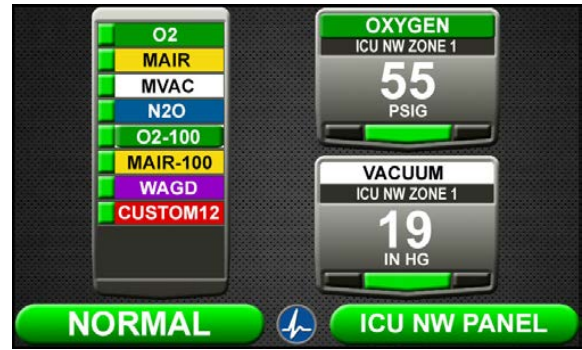

Figure 43: Combination Alarm Main Screen

4.1.5 Toolbar

Running from left to right across the bottom of the MAIN screen is the toolbar. The Normal toolbar is available when the alarm is operating in normal status and shows:



Figure 44: Normal Toolbar

To switch to the Icon toolbar, touch the HOME button.



Figure 45: Icon Toolbar

Icons on the toolbar:

1. Home button. This icon button toggles to the MAIN screen.
2. Alarm button. This icon button toggles to the ACTIVE ALARM screen.
3. Configuration button. This icon button toggles to the CONFIGURATION screen.
4. Information button. This icon button toggles to the INFORMATION screen.
5. History button. This icon button toggles to the HISTORY screen.

The button that corresponds to the screen currently in use will be blue.

4.1.6 Fault Status

If a gas sensor is measuring above or below the alarm level, the high or low pressure indicator on the gas badge will flash for the gas pressure out of range.

If a gas sensor becomes disconnected or shorted, both high and low indicators for that gas will flash and an error code and message will be displayed.

If a configured source signal becomes an open circuit, the source badge and the signal status will change from green to blinking red.

The Icon toolbar will appear, and the Alarm button will be flashing red. By default the screen will change to the Active Alarm Screen.



Figure 46: Fault Status

NOTE:

The Normal toolbar will automatically reappear when all faults are resolved.

Users can touch any flashing red light to go to the ACTIVE ALARM screen.

TotalAlert Infinity™ NFPA Medical Gas Notification System

4.1.7 Display Screens

Active Alarm Screen

The ACTIVE ALARM screen provides detailed information about pressures or signals that are in alarm condition. If an active alarm instruction has been set up, users will also see an instruction on how to respond to the alarm (see section 4.6 - Customized Instructions Set Up).

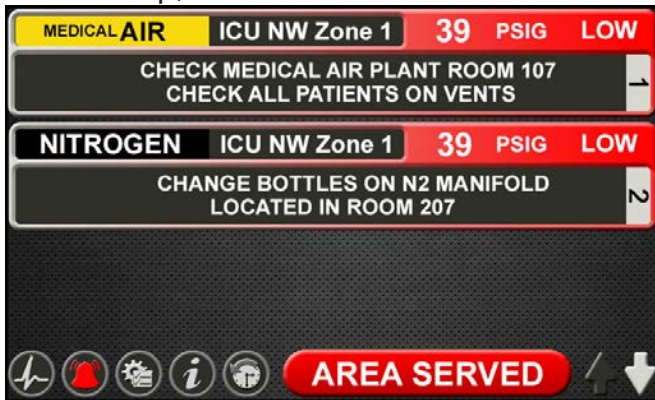

Figure 47: Active Alarm Screen

Configuration Screen

The CONFIGURATION screen is used to configure the alarm. The configuration screen is only accessible with a password. It is divided into three parts.

The top left section is the Display section. It contains a small representative view of the MAIN screen and buttons for configuring the MAIN screen.

The top right section is the Settings section. Tabs not accessible are grayed out.

The bottom section is the Icon toolbar.



Figure 48: Configuration Screen

Information Screen

The INFORMATION screen provides pertinent information about the alarm—including high and low alarm values and firmware details—in one central place.

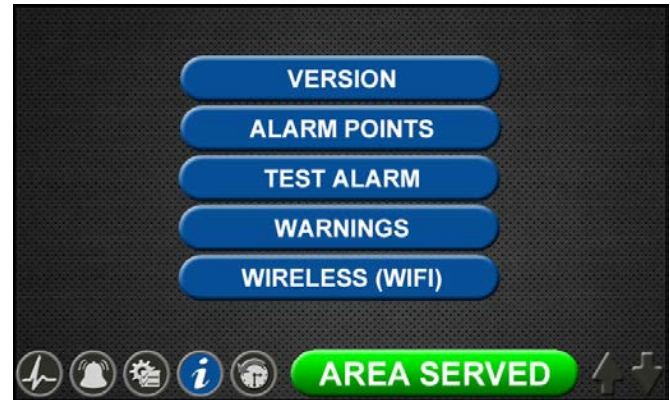

Figure 49: Information Screen

NOTE:

The Wireless (WIFI) tab is only present on the information screen if the default setting has been changed on the WIFI setting screen to allow WIFI control (See Section 4.8).

Version Tab

Touch the VERSION tab to view details about the:

- Series, code, and style of the alarm
- Firmware version for the main display board and additional boards



Figure 50: Version Tab

TotalAlert Infinity™ NFPA Medical Gas Notification System

NOTE:

The version screens automatically scroll. Touch the blinking up or down arrow in the lower right to stop the automatic scroll and start the manual scroll.

Touch the X button in the upper right to close and return to the INFORMATION screen.

Alarm Points Tab

Touch the ALARM POINTS tab for a quick view of the alarm points—the low and high set points—for each gas badge (area alarm) or source signal configuration (master alarm).

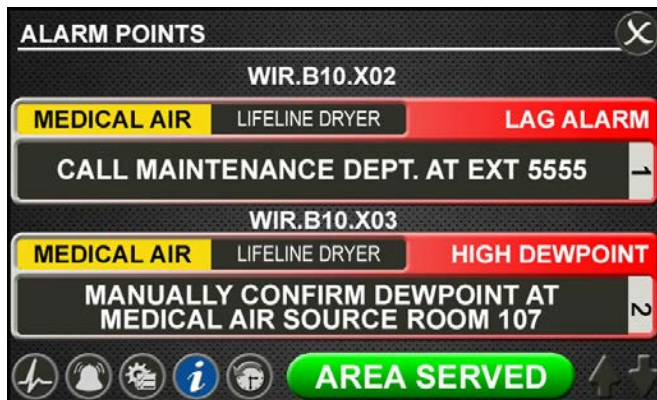

Figure 51: Alarm Points Tab

This screen provides a complete view of the configuration and is a fast way to check items such as:

- Location where the pressure sensors and source signals are physically wired.
- Gases Monitored
- Areas Monitored
- Low and high pressure set points for area signals
- Source Signals Monitored

Touch the X button in the upper right to close and return to the INFORMATION screen.

Test Alarm Tab

Touch the TEST ALARM tab to run a quick test of the hardware.

The audible alarm will sound for one-to-two seconds to test that the horn is working properly.

The LEDs on the front of the alarm will illuminate as well to show that they are still functioning.

Warnings Tab

Touch the WARNINGS tab to view any possible active warnings that would include lost network communication with manually enrolled devices, lost connection to a connected/initialized board, or when a master signal input is wired, but not assigned/programmed to an alarm signal.

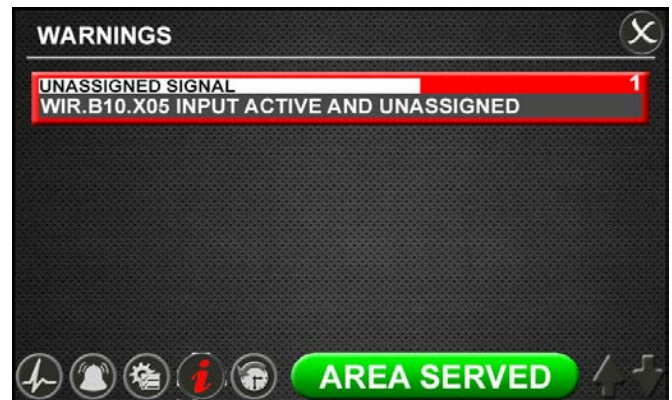

Figure 52: Warnings Tab

WIFI Tab

Touch the Wireless Ethernet (WIFI) tab to view WIFI Status (On or Off), SSID identification, and IP Address. WIFI Status can be turned On or Off by touching the designated tabs.



Figure 53: WIFI Tab

History Screen

To view up to 100 alarm events on screen, touch the history button located on the icon toolbar. User can easily scroll to view the events by touching up/down arrows in the bottom right corner of the screen.

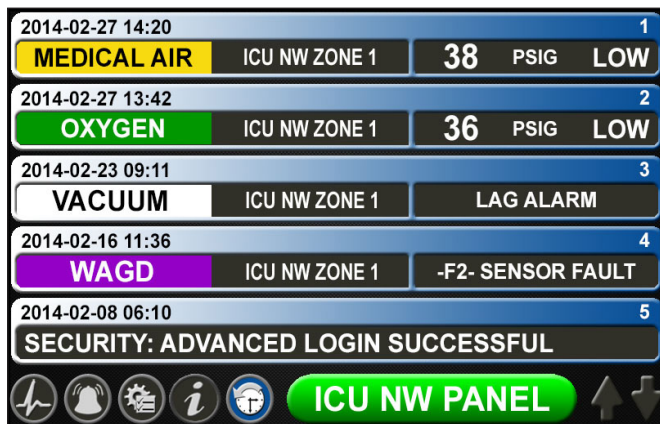

Figure 54: History Screen

4.2 Alarm Configuration

To set up or change the configuration of an alarm, start on the CONFIGURATION screen. Users are always prompted to enter the password when accessing this screen.



Figure 55: Password entry on Configuration screen

Type the default password (121212), and touch the Enter button. You will be prompted to change the password if you have not done so previously.

The CONFIGURATION screen displays.

Normal Status Message/Panel ID Description

The TotalAlert Infinity™ alarm allows for customization of certain labels and messages.

Normal Status Message

To change the message that is communicated when the alarm is operating in normal status:

1. Touch the [A] button that is located to the left of the numeric display (Figure 56).



Figure 56: Configuration Screen



Figure 57: Normal Status Message screen

2. Touch the Erase button on the keyboard to delete the existing message.
3. Enter the new word or message.
4. Touch the Save button.

Panel ID Description

To change the description of the location of the alarm panel:

1. Touch the [B] button that is located to the right of the numeric display (Figure 56).
2. Touch the Erase button on the keyboard to delete the existing description.
3. Enter the new description.
4. Touch the Save button.



Figure 58: Panel ID Description screen

4.3 Setting Up an Area Alarm



Figure 59: Area Alarm User Interface

4.3.1 Configuring Gas Badges

The TotalAlert Infinity™ area alarm is designed to allow configuration of eight gas badges using the B60 board.

To configure the first badge to custom settings, touch the [1] button in the numeric display of the configuration screen (Figure 56).

TotalAlert Infinity™ NFPA Medical Gas Notification System

Eight tabs are used for configuration (Figure 60). Tabs are listed in alphabetical order.

A = [GAS INPUT]	To change which wired input should be shown on the badge
B = GAS DESC	To change color codes based on standard and country
C = [GAS NAME]	To label the gas
D = AREA MONITORED	To edit the location label for the specific gas
E = [UNITS OF MEASURE]	To change the displayed unit of measure for the pressure/vacuum
F = LOW ALARM SETTINGS	To adjust the value that should indicate that the pressure is low
G = HIGH ALARM SETTINGS	To adjust the value that should indicate that the pressure is high
H = ZERO OFFSET	To make small adjustments to the displayed pressure based on user preference

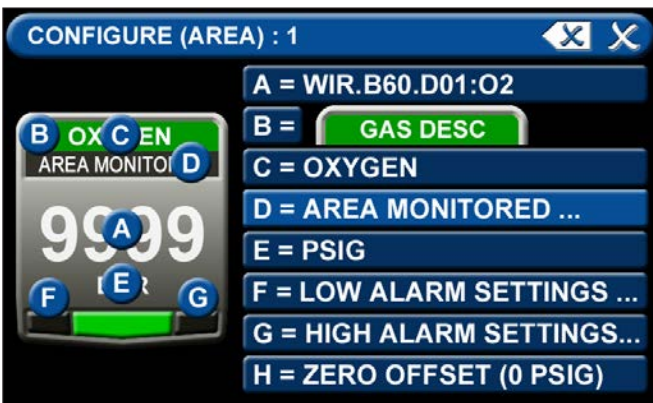

Figure 60: Configuring Gas Badges

A = [Gas Input] Tab

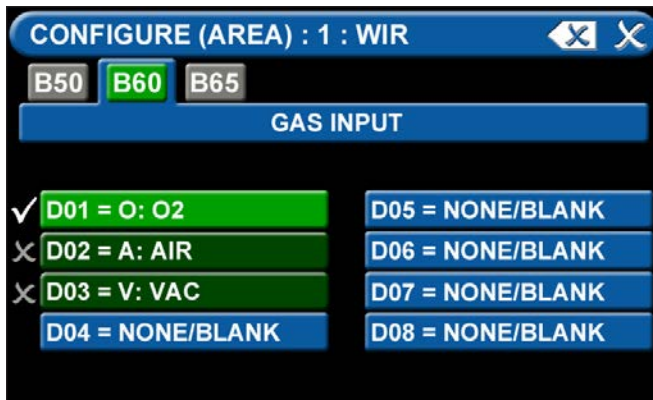

Figure 61: Gas Input Tab

To change which wired sensor should be displayed on that badge:

1. Touch the tab for the appropriate wired gas sensor.
2. Touch the Save button to close the screen.

B = Gas Desc Tab

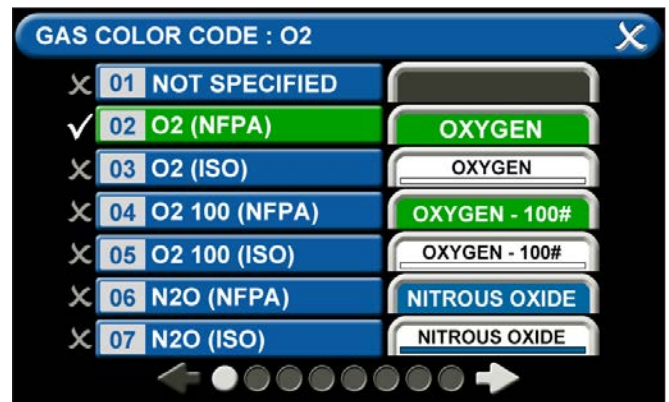

Figure 62: Gas Desc Tab

To change color codes based on your standard and country:

1. Scroll through the codes using the right and left arrows at the bottom of the screen.
2. Touch the tab for the appropriate code.
3. Touch the Save button when you see a check beside your selection.

NOTE:

If the alarm default is correct, touch the X button in the upper right to close the screen.

TotalAlert Infinity™ NFPA Medical Gas Notification System

C = [Gas Name] Tab



Figure 63: Gas Name Tab

- Touch the Erase button on the keyboard to delete the gas name.
- Enter the new gas name. Touch the [<ÁÑ] to toggle to symbols and extended Latin Characters. Touch the [1AZ] key to toggle back to letters and numbers.
- Touch the Save button

D = Area Monitored Tab



Figure 64: Area Monitored Tab

To add locations to be monitored:

1. Touch an unused location tab.
2. Using the keyboard, enter the name of the location that you would like to monitor (e.g., ROOM 1). Enter multiple locations as needed (e.g., Room 1, Room 5).
3. A check appears when the location is selected, the save button has to be pressed if the selection is new.

To edit the location information, touch the Pencil button.

E = [Units of Measure] Tab



Figure 65: Units of Measure Tab

To change the unit of measure:

1. Touch the tab for the appropriate unit of measure.
2. Touch the Save button to close the screen.

F = Low Alarm Settings Tab

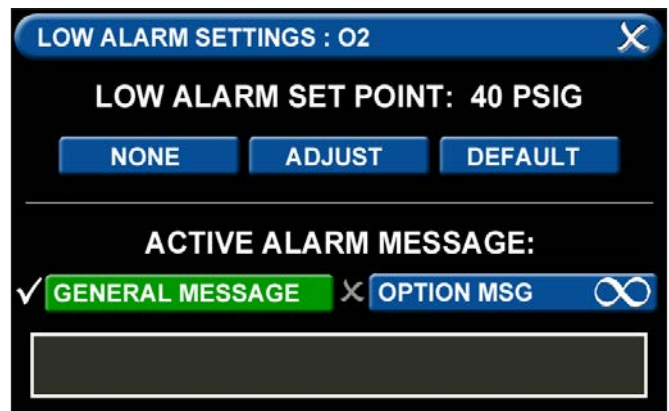

Figure 66: Low Alarm Settings Tab

You can remove the low alarm set point or customize the low alarm set point.

To remove the low alarm set point:

1. Touch the NONE tab.
2. Touch the check on the CONFIRM SETTINGS CHANGE screen.

To customize the low alarm set point:

1. Touch the ADJUST tab.
2. Enter the new set point.
3. Touch the Save button.

Active Alarm Instruction:

To set facility instructions for active alarms, touch either the GENERAL MESSAGE or OPTION MSG tab. The alarm defaults to GENERAL MESSAGE. See Section 4.6 for how to set up custom instructions.

G = High Alarm Settings Tab

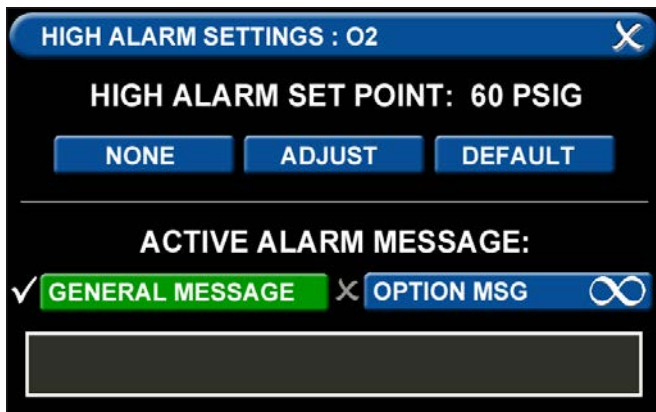

Figure 67: High Alarm Settings Tab

You can remove the high alarm set point or customize the high alarm set point.

To remove the high alarm set point:

1. Touch the NONE tab.
2. Touch the check on the CONFIRM SETTINGS CHANGE screen.

To customize the high alarm set point:

1. Touch the ADJUST tab.
2. Enter the new set point.
3. Touch the Save button.

H = Zero Offset Tab



Figure 68: Zero Offset Tab

In some cases, facility dial gauges may show slightly different readings than the TotalAlert Infinity™ alarm (e.g., 46 PSI versus 44 PSI). To match the TotalAlert Infinity™ alarm exactly to a facility dial gauge:

1. Select the offset amount.
2. Touch the Save button to close the screen.

Configuring Additional Gas Badges

Configure additional gas badges by touching the number on the main configuration screen that corresponds with the gas badge and repeating the steps listed above.

4.3.2 Initial Setup of an Unconfigured Area Alarm

The SETUP INFORMATION screen is the first screen that users will see on an unconfigured alarm. (The MAIN screen is the first screen that users will see on a configured alarm.)

Password Setup - Unconfigured Alarm

- Touch the Configuration button.



Configuration Button

Figure 69: Setup Information Screen

Entering the Password

The ENTER SECURITY PASSWORD screen appears.



Figure 70: Entering the Security Password

- Enter the security password. (The default password is **121212**.)
- Touch the Enter button.
- Touch Continue to advance to the CONFIGURATION screen.

Note:

If you would like to change the password, touch Change Password. Enter a 4-10 digit password, and touch the Enter button. Confirm the new password. Touch the X button in the upper right to close the SECURITY PASSWORD screen.



Figure 71: Changing the Security Password

- The CONFIGURATION screen will display as unconfigured and ready for setup.



Figure 72: Unconfigured Configuration Screen

TotalAlert Infinity™ NFPA Medical Gas Notification System

Primary Settings Tab

The PRIMARY SETTINGS tab allows you to select the alarm type, initialize boards, and select gas inputs.

- Touch the PRIMARY SETTINGS tab



Alarm Type Tab

The ALARM TYPE screen defines which type of alarm will be displayed and drives later setup functions.

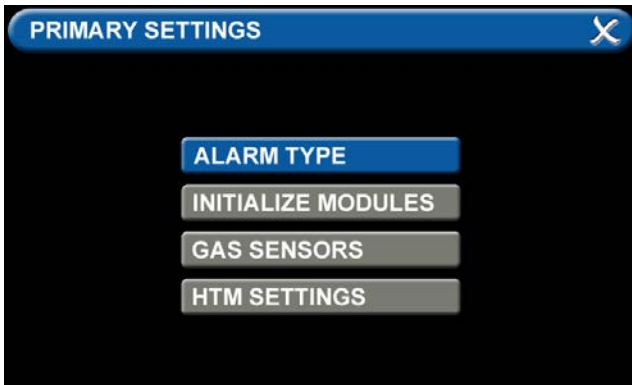

Figure 73: Alarm Type Tab

- Touch the ALARM TYPE tab.
- Choose a code style based on code requirements.

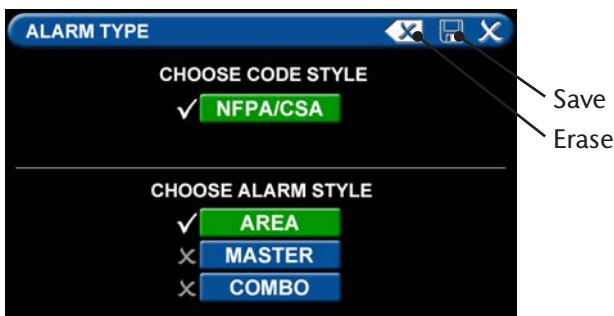

Figure 74: Choosing Code and Alarm Styles

- Touch the AREA tab
- Touch the Save button when you see checks beside your selections to save the settings and return to the PRIMARY SETTINGS screen.

Note: To clear your selections, touch the Erase button.

Initialize Modules Tab

The PRIMARY SETTINGS screen will now display with ALARM TYPE checked, INITIALIZE MODULES active, and the other tabs grayed out.

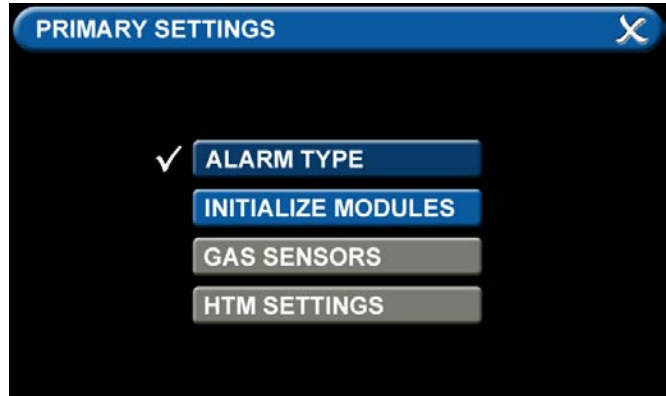

Figure 75: Initialize Modules Tab

- Touch the INITIALIZE MODULES tab.

The INITIALIZE MODULES screen is used to set up the boards that are installed. The boards function as the input/output hardware of the alarm.

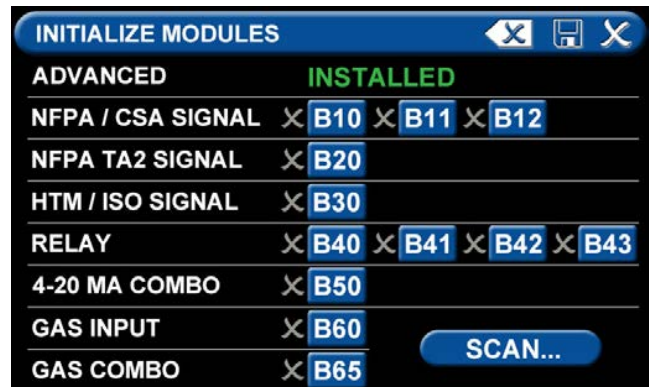

Figure 76: Initialize Modules Screen

At this point, you have two options:

1. Either touch the Scan button to prompt the alarm to auto fill the screen for you.
- OR
2. Complete the screen by selecting the boards installed in the alarm.

TotalAlert Infinity™ NFPA Medical Gas Notification System

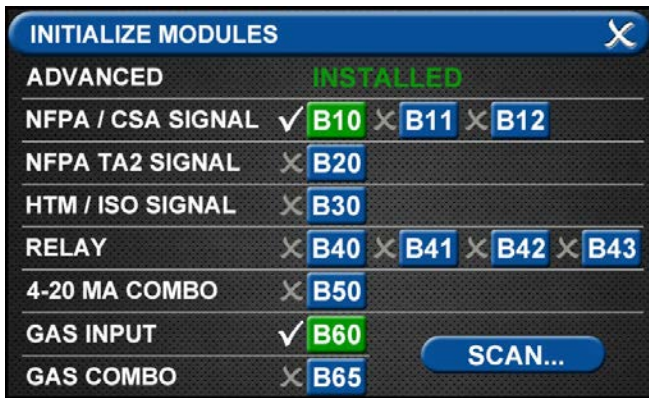

Figure 77: B60 board selected

Note:

THE GAS INPUT / B60 board must be selected during the configuration of an area alarm.

- Touch the Save button when you see checks beside your selections.

Gas Sensors Tab

The PRIMARY SETTINGS screen will now display with ALARM TYPE and INITIALIZE MODULES checked, GAS SENSORS active, and the last tab grayed out.

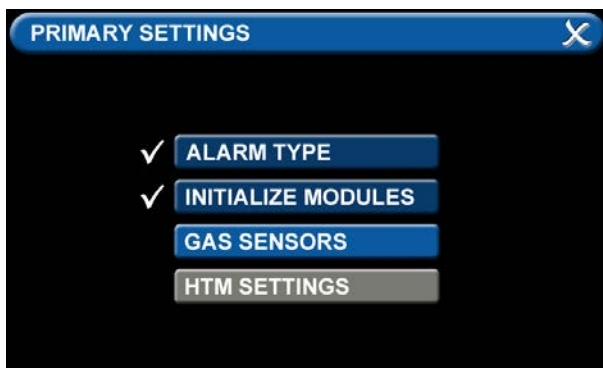

Figure 78: Gas Sensors Tab

- Touch the GAS SENSORS tab.

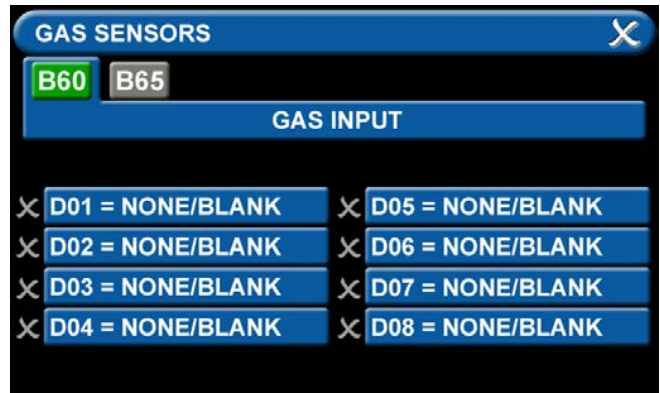

Figure 79: Gas Input Screen

Users may select up to eight different gases on the GAS INPUT screen. These gases correspond to the digital gas sensors wired into the GAS INPUT / B60 board (see section 2.4.2).

- To select the first gas, touch the D01 = NONE/BLANK tab.



Figure 80: Gas Sensors Screen

TotalAlert Infinity™ NFPA Medical Gas Notification System

- Touch the right and left arrows at the bottom of the screen to scroll through additional gas choices, including options to create custom mixes. Select the gas that is wired into the D01 input on the GAS INPUT / B60 board.



Figure 81: Gas Choices

- Touch the Save button when you see a check beside your selection.
- (If an alarm sounds, press the Mute button on the panel under the screen and continue with setup.)
- Repeat to add additional gases.
- Touch the X button in the upper right to close the GAS SENSORS screen and return to the PRIMARY SETTINGS screen. The alarm will retain your information.
- Touch the X button in the upper right to close the PRIMARY SETTINGS screen. The alarm will retain your information.

TotalAlert Infinity™ NFPA Medical Gas Notification System

4.4 Setting Up a Master Alarm

The master alarm monitors whether source equipment is working properly. Two independent hard wired alarms are required per facility to meet the 24-hour monitoring requirement in the NFPA 99 standard.

The information for the signals connected in the field needs to be entered into the alarm using the touch screen interface.



Figure 82: Master Alarm User Interface

To set up or change the configuration of an alarm, follow the steps outlined under Alarm Type Tab.

4.4.1 Configuring Source Badges

The TotalAlert Infinity™ master alarm is designed to allow the setup and monitoring of 12 source badges. Forty source locations with up to 8 source signal inputs for each location can be configured (maximum of 20 locations per gas type).



Figure 83: Configuration Screen

Note:

Maximum wired input signals allowed is 60.

To configure alarm points in the first badge, touch the [1] button in the numeric display (Figure 83).

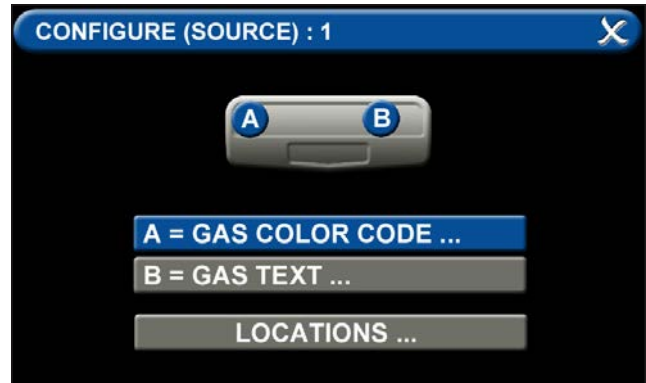

Figure 84: Configuration Source Screen

A = Gas Color Code Tab

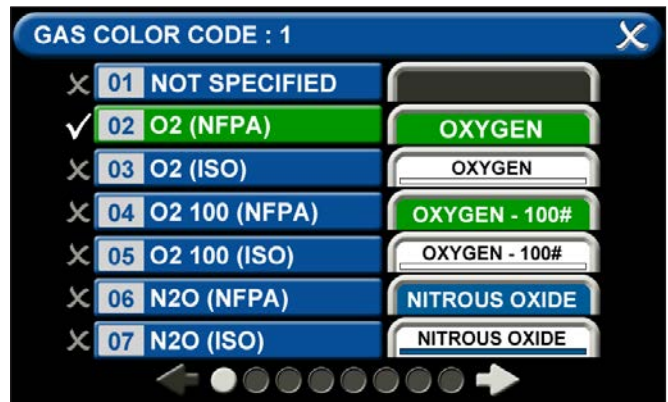

Figure 85: Gas Color Code Tab

To select the color code for the appropriate gas based on your standard and country:

1. Touch the A = GAS COLOR CODE tab (Figure 84).
2. Scroll through the gas types using the right and left arrows at the bottom of the screen.
3. Touch the tab for the appropriate code, or select a “custom” tab to create a unique source badge.
4. Touch the Save button when you see a check beside your selection.

B = [Gas Text] Tab



Figure 86: Gas Text Tab

To change the name of the gas:

1. Touch the B = [GAS TEXT] tab (Figure 84).
2. Touch the Erase button on the keyboard to delete the gas name.
3. Enter the new gas name. Touch the [<ÁÑ] to toggle to symbols. Touch the [1AZ] key to toggle back to letters and numbers.
4. Touch the Save button.

- **Locations Tab**

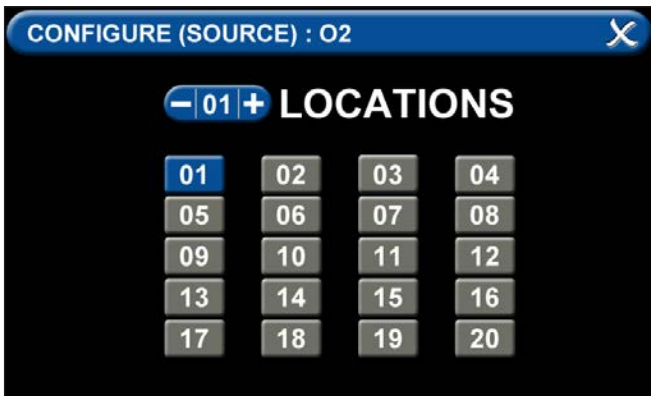

Figure 87: Locations Tab

To select the number of locations to be monitored for this particular gas:

1. Touch the LOCATIONS tab on the configuration screen (Figure 84).
2. Using the [+] and [-] buttons to increase and decrease the number of locations.
3. Touch the 01 button to go the CONFIGURE (SOURCE) screen to configure the first location (Figure 88).

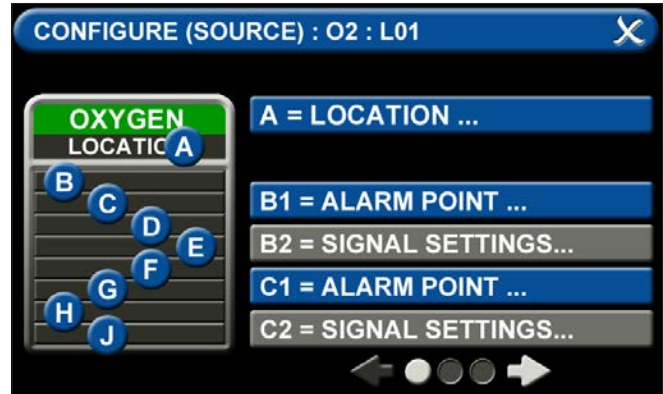

Figure 88: Configure Source Badges

Touch the A = [Location] Tab



Figure 89: Location Tab Screen

On the SOURCE LOCATION screen:

Touch the 01 tab.

1. Using the keyboard, enter the name of the location for the source equipment being monitored (e.g., ROOM 1). Enter multiple locations as needed (e.g., Manifold Room, Roof Top, Source Room).
2. Touch the Save button. A check appears when the location is saved. Note: To edit the location, touch the Pencil button.
3. Touch the X button to close and return to the CONFIGURE (SOURCE) screen.

TotalAlert Infinity™ NFPA Medical Gas Notification System

Each source badge has room for eight source signal inputs (B-J) (Figure 88). Two tabs are used for the detailed configuration of each source signal input. The two tabs for each source signal input are paired and named alphabetically (e.g., B1 and B2 / C1 and C2 / D1 and D2 / etc.).

Users can scroll to the first tab for each source signal input by using the right and left arrows at the bottom of the screen. To jump quickly to the second and third screens, simply touch a letter button on the grid on the left that appears on that screen (e.g., the D button jumps to the second screen and the G button jumps to the third screen).

The first tab for each source signal input is highlighted and the second grayed out to ensure that users complete the setup in the correct order. The second tab in each pair will become available to you as you advance through setup.

B1 = Alarm Point Tab

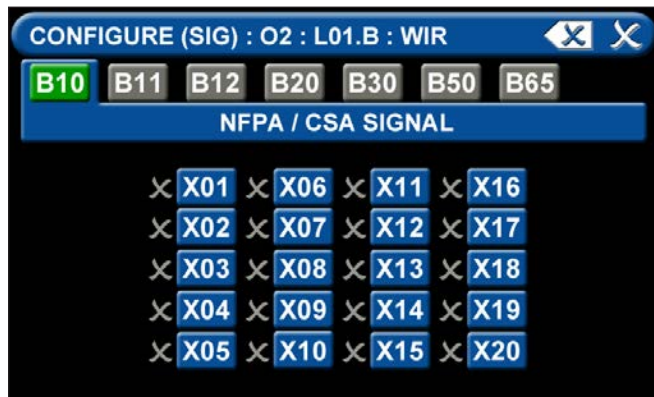

Figure 90: Alarm Points Tab

To identify the location where the wires are landed:

1. Touch the tab for the appropriate board and terminal block. Ex: B10 Board, X01 Terminal Block
2. Touch the Save button when you see a check beside your selection to go automatically to the SIGNAL SETTINGS screen.

B2 = Signal Settings Tab

Signal Text

- Touch the NONE/BLANK tab

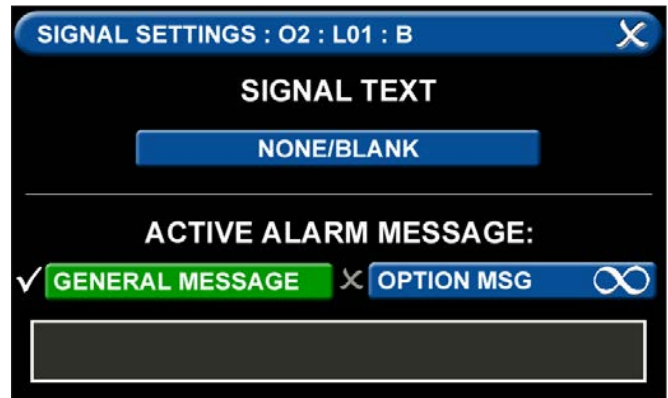

Figure 91: Signal Text

To select source signal input text:

- Scroll through the options using the right and left arrows at the bottom of the screen.
- Touch the tab for the appropriate option, or select a blank to create a custom alarm.
- Touch the Save button when you see a check beside your selection to close and return to the SIGNAL SETTINGS screen.
- Touch the X button in the upper right to close and return to the CONFIGURE (SOURCE) screen.

Active Alarm Instruction:

To set facility instructions for active alarms, touch either the GENERAL MESSAGE or OPTION MSG tab. The alarm defaults to GENERAL MESSAGE. See Section 4.6 for how to set up custom instructions.

Configuring Additional Source Badges

Configure alarm points on additional source badges by touching the number on the numeric display that corresponds with the source badge and repeating the steps listed above.

4.4.2 Initial Setup of an Unconfigured Master Alarm

The SETUP INFORMATION screen is the first screen that users will see on an unconfigured alarm.

(The MAIN screen is the first screen that users will see on a configured alarm).

- Touch the Configuration button.



Configuration Button

Figure 92: Setup Information Screen

Entering the Password

The ENTER SECURITY PASSWORD screen appears.



Figure 93: Entering the Security Password

- Enter the security password. (The default password is 121212.)
- Touch the Enter button.
- Touch Continue to advance to the CONFIGURATION screen.

Note:

If you would like to change the password, touch Change Password. Enter a 4-10 digit password, and touch the Enter button. Confirm the new password. Touch the X button in the upper right to close the SECURITY PASSWORD screen.

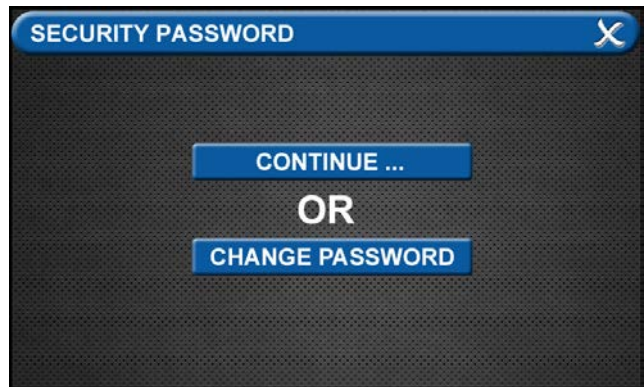

Figure 94: Changing the Security Password

- The CONFIGURATION screen will display as unconfigured and ready for setup

Primary Settings Tab

The PRIMARY SETTINGS tab allows you to select the alarm type and initialize boards.



- Touch the PRIMARY SETTINGS tab.

TotalAlert Infinity™ NFPA Medical Gas Notification System

Alarm Type Tab

The ALARM TYPE screen defines which type of alarm will be displayed and drives later setup functions.

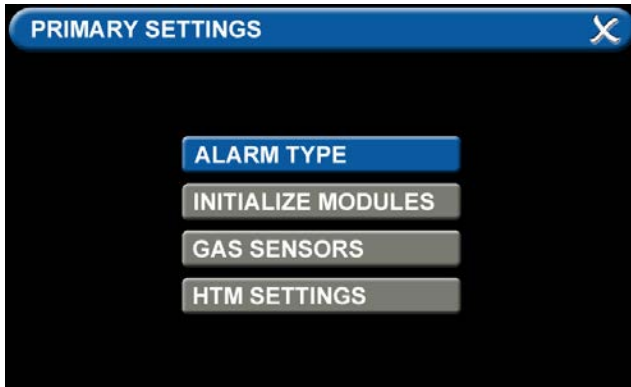

Figure 95: Alarm Type Tab

- Touch the ALARM TYPE tab.
- Choose a code style based on code requirements.
- Touch the MASTER tab.

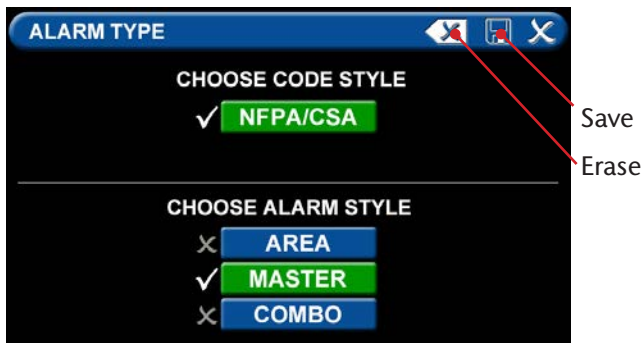

Figure 96: Choosing Code and Alarm Styles

- Touch the Save button when you see checks beside your selections to close the screen and return to the PRIMARY SETTINGS screen.

Note: To clear your selections, touch the Erase button.

Initialize Modules Tab

The PRIMARY SETTINGS screen will now display with ALARM TYPE checked and INITIALIZE MODULES active.

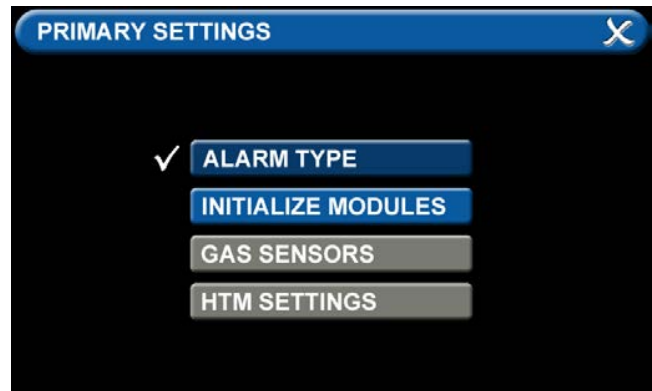

Figure 97: Initialize Modules Screen

- Touch the INITIALIZE MODULES tab.

The INITIALIZE MODULES screen is used to set up the boards that are installed. The boards function as the input/output hardware of the alarm.

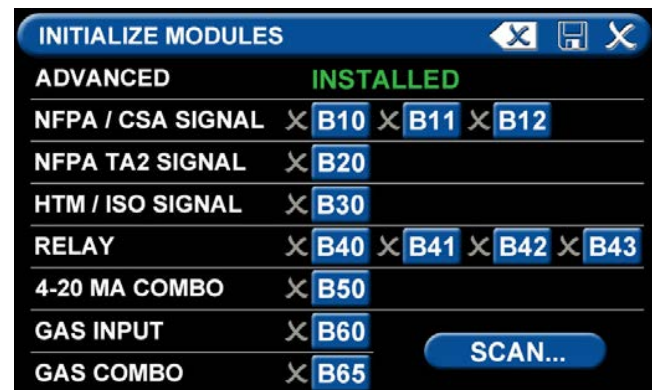

Figure 98: Initialize Modules Screen

At this point, you have two options:

1. Either touch the Scan button to prompt the alarm to autofill the screen for you.

OR

2. Complete the screen by selecting the boards installed in the alarm.

Touch the Save button when you see checks beside your selections.

The PRIMARY SETTINGS screen will now display with ALARM TYPE and INITIALIZE MODULES highlighted and checked and the other tabs grayed out.

- Touch the X button in the upper right to close and return to the CONFIGURATION screen.

NOTE:

See the end of this section for information on the Miscellaneous Tab. See section 4.6 for information on the Active Alarm Opt Tab.

4.5 Setting up a Combination Alarm



Figure 99: Combination Alarm User Interface

The TotalAlert Infinity™ combination alarm combines the functionality of an area alarm and a master alarm. It monitors two things:

- Gases and their pressures.
- Source equipment.

Two independent hard wired alarms monitoring source equipment are required per facility to meet the 24-hour monitoring requirement in the NFPA 99 standard.

4.5.1 Configuring Source Badges

The TotalAlert Infinity™ combination alarm is designed to allow the configuration of ten source badges. Twenty locations with up to eight source signals each can be tied to each source badge.

To configure alarm points in a master badge, touch the [1] button on the configuration screen (Figure 101).



Figure 100: Combination Alarm Screen

- **Configure (Source) Screen**

Ten gases (A-K) can be tied to master badges. Three tabs are used for the configuration of each source badge (Figure 102).

1 = GAS COLOR CODE	To change color codes based on standard and country
2 = GAS TEXT	To label the gas
3 = LOCATIONS	To add a location for the source signal



Figure 101: Configure Source Screen

TotalAlert Infinity™ NFPA Medical Gas Notification System

The three tabs for each source badge are grouped together and named alphabetically (e.g., A1, A2, A3, / B1, B2, B3, B4 / C1, C2, C3, C4 / etc.).

Users can scroll to the first tab for each source badge by using the right and left arrows at the bottom of the screen. Or, to jump quickly to the first tab, simply touch the letter button on the grid on the left that corresponds to the source badge (A-K) (Figure 102).

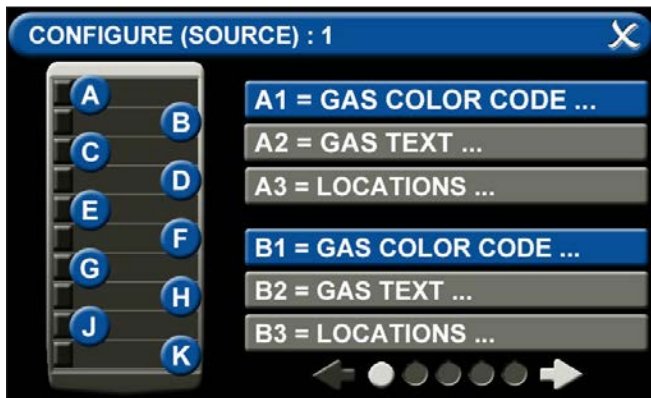

Figure 102: Configure Source Badges

The first tab under each source badge is highlighted and the remainder grayed out to ensure that users complete the setup in the correct order. The other tabs will become available to you as you advance through setup.

A1 = Gas Color Code Tab

To select the color code for the appropriate gas based on your standard and country:

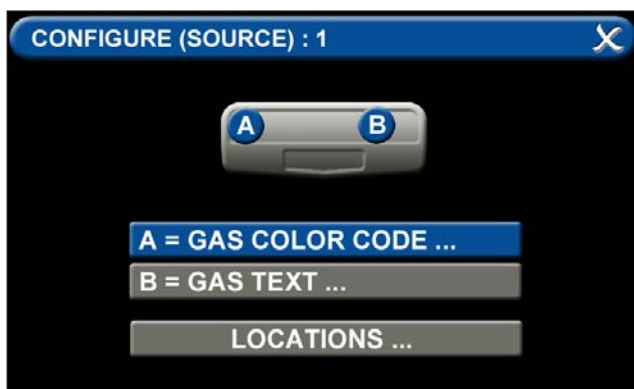

Figure 103: Configuration Screen

1. Touch the A = GAS COLOR CODE tab.

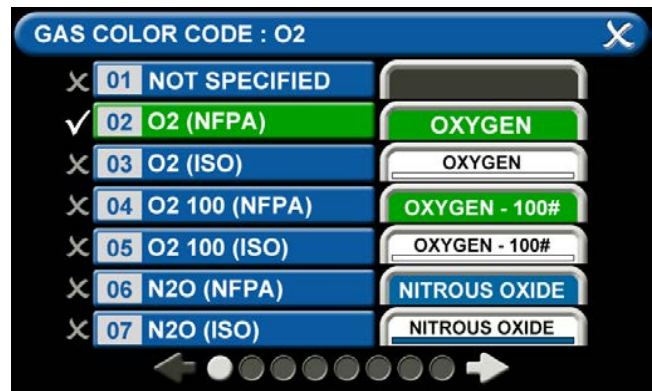

Figure 104: Gas Color Code Screen

2. Scroll through the gas types using the right and left arrows at the bottom of the screen.
3. Touch the tab for the appropriate code, or select a “custom” tab to create a unique source badge.
4. Touch the Save button when you see a check beside your selection.

A2 = [Gas Text] Tab

To change the name of the gas:



Figure 105: Gas Text Screen

1. Touch the A2 = [GAS TEXT] tab.
2. Touch the Erase button on the keyboard to delete the gas name.
3. Enter the new gas name. Touch the [<AÑ] to toggle to symbols. Touch the [1AZ] key to toggle back to letters and numbers.
4. Touch the Save button.

TotalAlert Infinity™ NFPA Medical Gas Notification System

A3 = Locations Tab

To select the number of locations to be monitored for this particular gas:

1. Touch the LOCATIONS tab.
2. Use the [+] and [-] buttons to increase and decrease the number of locations.
3. Touch the 01 button to go automatically to the CONFIGURE (SOURCE) : O2 screen

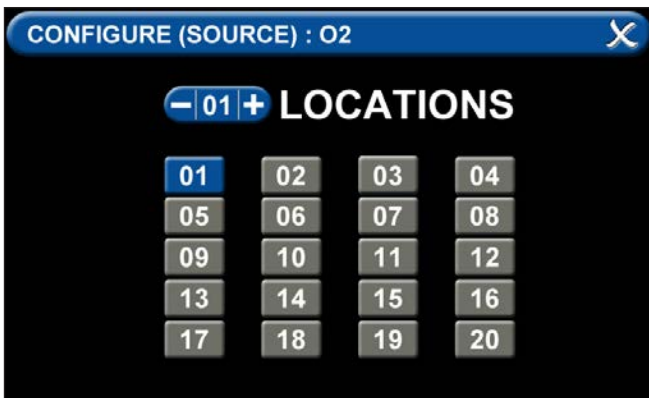

Figure 106: Locations Tab

- **Configure (Source): O2 Screen**

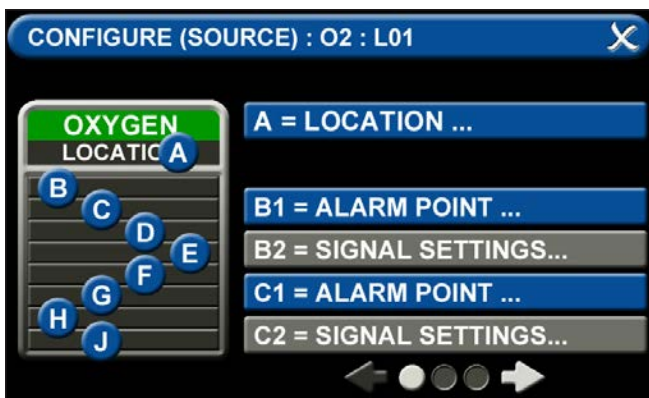

Figure 107: Configure Source Screen

A = [Location] Tab

To name the location, touch the A = [LOCATION] button.



Figure 108: [Location] Tab

On the SOURCE LOCATION screen:

1. Touch the 01 tab.
2. Using the keyboard, enter the name of the location for the source equipment being monitored (e.g., ROOM 1). Enter multiple locations as needed (e.g., Manifold Room, Roof Top, Source Room).
3. Touch the Save button. A check appears when the location is saved. Note: To edit the location, touch the Pencil button.
4. Touch the X button to close and return to the CONFIGURE (SOURCE) screen.

TotalAlert Infinity™ NFPA Medical Gas Notification System

Eight source signal inputs (B-J) can be tied to each location. Two tabs are used for the detailed configuration of each source signal input. The two tabs for each source signal input are paired and named alphabetically (e.g., B1 and B2 / C1 and C2 / D1 and D2 / etc.) (Figure 107).

Users can scroll to the first tab for each source signal input by using the right and left arrows at the bottom of the screen. To jump quickly to the second and third screens, simply touch a letter button on the grid on the left that appears on that screen (e.g., the D button jumps to the second screen and the G button jumps to the third screen).

The first tab for each source signal input is highlighted and the second grayed out to ensure that users complete the setup in the correct order. The second tab in each pair will become available to you as you advance through setup.

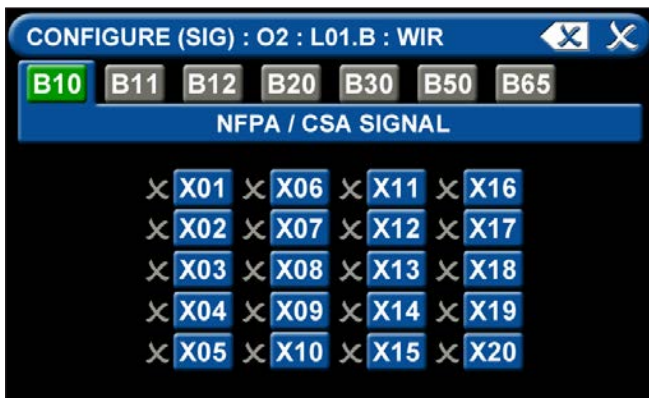

Figure 109: Alarm Point Tab

B1 = Alarm Point Tab

To identify the location where the wires are landed:

1. Touch the B1 tab
2. Touch the tab for the appropriate board and terminal block.
3. Touch the Save button when you see a check beside your selection to go automatically to the SIGNAL SETTINGS screen.

B2 = Signal Settings Tab

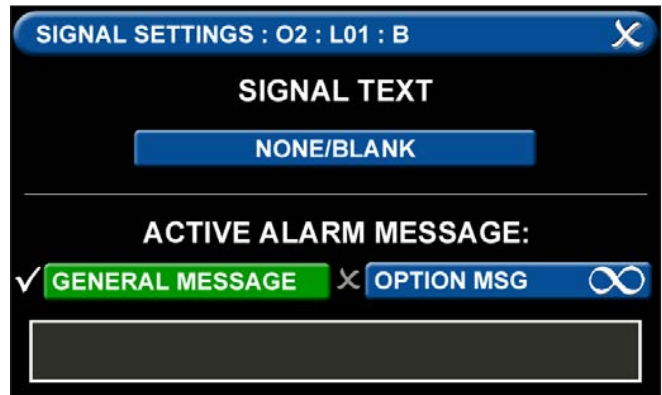

Figure 110: Signal Settings tab

- **Signal Text**

Touch the NONE/BLANK tab.



Figure 111: Signal Text Tab

To select source signal input text:

- Scroll through the options using the right and left arrows at the bottom of the screen.
- Touch the tab for the appropriate option, or select a blank to create a custom alarm.
- Touch the Save button when you see a check beside your selection to save the selection and return to the SIGNAL SETTINGS screen.

Active Alarm Instruction:

To set facility instructions for active alarms, touch either the GENERAL MESSAGE or OPTION MSG tab. The alarm defaults to GENERAL MESSAGE. See Section 4.6 for how to set up custom instructions.

4.5.2 Configuring Gas ID Badges

The TotalAlert Infinity™ combination alarm is designed to allow configuration of up to six area badges using the B60 board or up to three area badges using the B65 board.



Figure 112: Configuring Area Badges

To configure the first badge to custom settings, touch the [2] button in the numeric display.



Figure 113: Configuring Area Badges

TotalAlert Infinity™ NFPA Medical Gas Notification System

Eight tabs are used for configuration (Figure 113). Tabs are listed in alphabetical order.

A = [GAS INPUT]	To change which wired input should be shown on the badge
B = GAS DESC	To change color codes based on standard and country
C = [GAS NAME]	To label the gas
D = AREA MONITORED	To edit the location label for a specific gas
E = [UNITS OF MEASURE]	To change the displayed unit of measure for the pressure/vacuum
F = LOW ALARM SETTINGS	To adjust the value that indicates that the pressure is low
G = HIGH ALARM SETTINGS	To adjust the value that indicates that the pressure is high
H = ZERO OFFSET	To make small adjustments to the displayed pressure based on user preference

A = [Gas Input] Tab

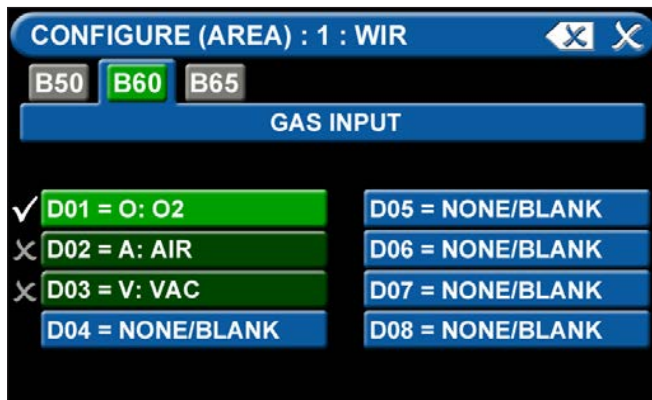

Figure 114: [Gas Input] Tab

To change which wired sensor should be displayed on that badge:

1. Touch the tab for the appropriate wired gas sensor.
2. Touch the Save button to close the screen

B = Gas Desc Tab

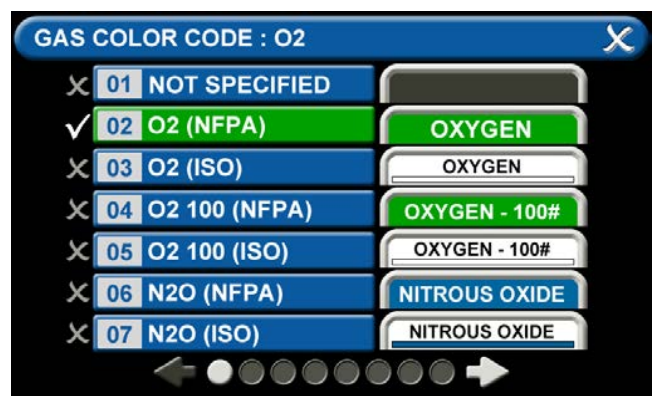

Figure 115: Gas Color Code Screen

To change color codes based on your standard and country:

1. Scroll through the codes using the right and left arrows at the bottom of the screen.
2. Touch the tab for the appropriate code.
3. Touch the Save button when you see a check beside your selection.

Note: If the alarm default is correct, touch the X button in the upper right to close the screen.

C = [Gas Name] Tab



Figure 116: Gas Text Screen

1. Touch the Erase button on the keyboard to delete the gas name.
2. Enter the new gas name. Touch the [<ÁÑ] to toggle to symbols. Touch the [1AZ] key to toggle back to letters and numbers.
3. Touch the Save button.

D = Area Monitored Tab



Figure 117: Area Monitored

To add locations to be monitored:

1. Touch an unused location tab.
2. Using the keyboard, enter the name of the location that you would like to monitor (e.g., ROOM 1). Enter multiple locations as needed (e.g., Room 1, Room 2, Room 5).
3. Touch the Save button. A check appears when the location is saved.

Note: To edit the location information, touch the Pencil button.

E = [Units Of Measure] Tab



Figure 118: [Units of Measure] Tab

To change the unit of measure:

1. Touch the tab for the appropriate unit of measure.
2. Touch the Save button to close the screen

F = Low Alarm Settings Tab

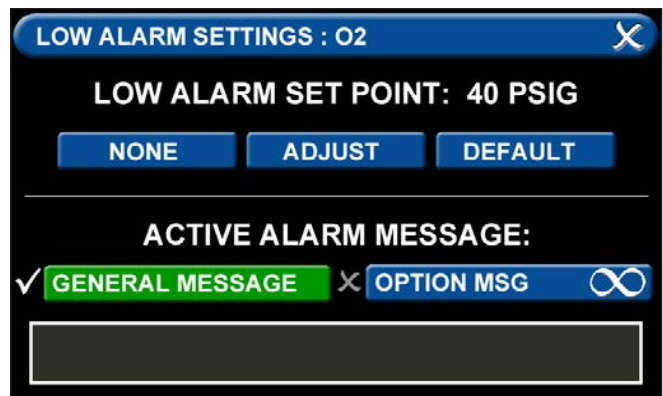

Figure 119: Low Alarm Settings Tab

• Low Alarm Set Point

You can remove the low alarm set point or customize the low alarm set point.

To remove the low alarm set point:

1. Touch the NONE tab.
2. Touch the check on the CONFIRM SETTINGS CHANGE screen.

To customize the low alarm set point:

1. Touch the ADJUST tab.
2. Enter the new set point.
3. Touch the Save button.

Active Alarm Instruction:

To set facility instructions for active alarms, touch either the GENERAL MESSAGE or OPTION MSG tab. The alarm defaults to GENERAL MESSAGE. See Section 4.6 for how to set up custom instructions.

G = High Alarm Settings Tab

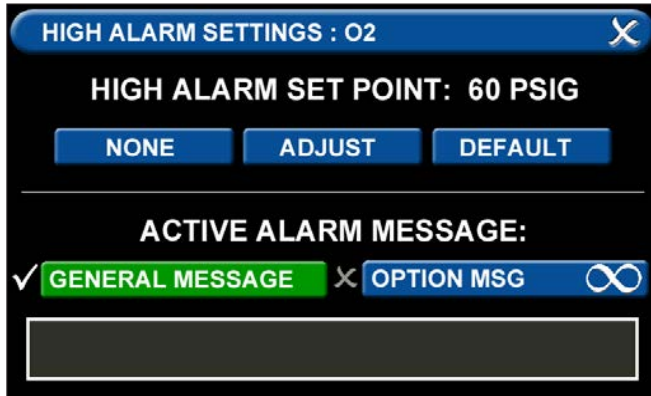

Figure 120: High Alarm Settings Tab

You can remove the high alarm set point or customize the high alarm set point.

To remove the high alarm set point:

1. Touch the NONE tab.
2. Touch the check on the CONFIRM SETTINGS CHANGE screen.

To customize the high alarm set point:

1. Touch the ADJUST tab.
2. Enter the new set point.
3. Touch the Save button.

H = Zero Offset Tab



Figure 121: Zero Offset Tab

In some cases, facility dial gauges may show slightly different readings than the TotalAlert alarm (e.g., 46 PSI versus 44 PSI). To match the TotalAlert alarm exactly to a facility dial gauge:

1. Select the offset amount.
2. Touch the Save button to close the screen.

Configuring Additional Area Badges

Configure additional area badges by touching the number on the numeric display that corresponds with the area badge and repeating the steps listed above.

4.5.3 Initial Setup of an Unconfigured Combination Alarm

The SETUP INFORMATION screen is the first screen that users will see on an unconfigured alarm.

(The MAIN screen is the first screen that users will see on a configured alarm).

- Touch the Configuration button.



Configuration Button

Figure 122: Setup Information Screen

Entering the Password

The ENTER SECURITY PASSWORD screen appears.



Figure 123: Entering the Security Password

Enter the security password. (The default password is **121212**.)

- Touch the Enter button.
- Touch Continue to advance to the CONFIGURATION screen.

NOTE:

If you would like to change the password, touch Change Password. Enter a 4-10 digit password, and touch the Enter button. Confirm the new password. Touch the X button in the upper right to close the SECURITY PASSWORD screen.

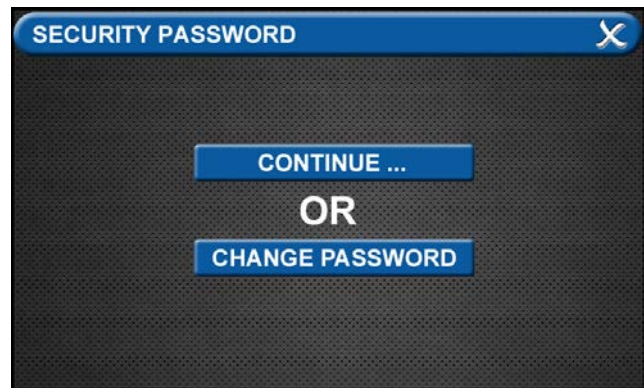

Figure 124: Changing the Security Password

- The CONFIGURATION screen will display as unconfigured and ready for setup.

Primary Settings Tab

The PRIMARY SETTINGS tab allows you to select the alarm type and initialize boards.



- Touch the PRIMARY SETTINGS tab.

TotalAlert Infinity™ NFPA Medical Gas Notification System

- **Alarm Type Tab**

The ALARM TYPE screen defines which type of alarm will be displayed and drives later setup functions.

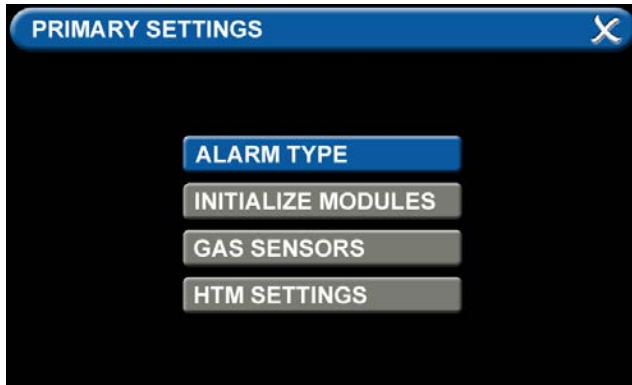

Figure 125: Alarm Type Tab

- Touch the ALARM TYPE tab.
- Choose a code style based on code requirements.
- Touch the COMBO tab.

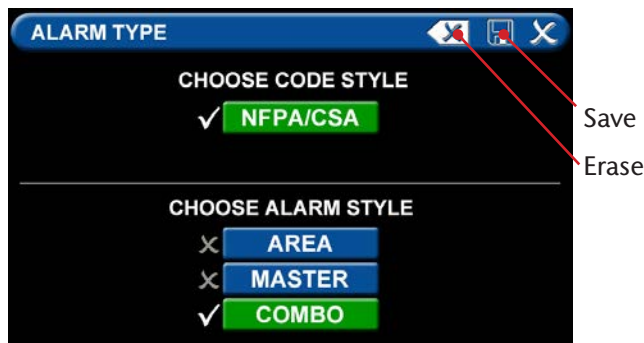

Figure 126: Choosing Code and Alarm Styles

- Once the desired tabs are selected, touch the Save button to save the selection and go back to the PRIMARY SETTINGS screen.

Note: To clear your selections, touch the Erase button.

- **Initialize Modules Tab**

The PRIMARY SETTINGS screen will now display with ALARM TYPE checked and INITIALIZE MODULES active.

- Touch the INITIALIZE MODULES tab.

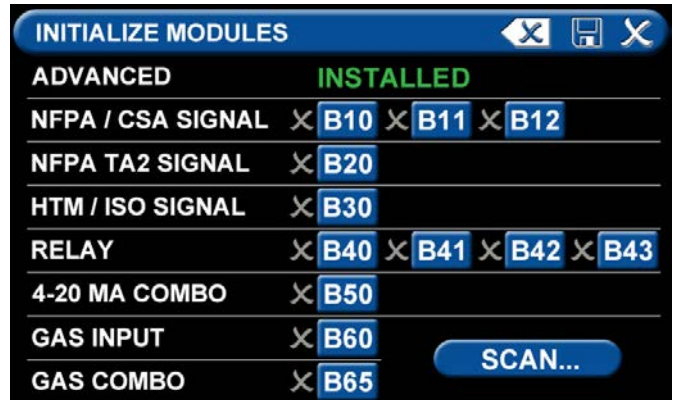

Figure 127: Initialize Modules Screen

The INITIALIZE MODULES screen is used to set up the boards that are installed. The boards function as the input/output hardware of the alarm.

At this point, you have two options:

1. Either touch the Scan button to prompt the alarm to autofill the screen for you.

OR

2. Complete the screen by selecting the boards installed in the alarm.

Touch the Save button when you see checks beside your selections.

Notes:

1. Select the NFPA/CSA SIGNAL / B1x board during the configuration of a combination alarm.
2. Select Gas Input / B60 or Gas Combination / B65 depending on hardware installed in the alarm.

Gas Sensors Tab

The PRIMARY SETTINGS screen will now display with ALARM TYPE and INITIALIZE MODULES checked, GAS SENSORS active, and the last tab grayed out.

- Touch the GAS SENSORS tab

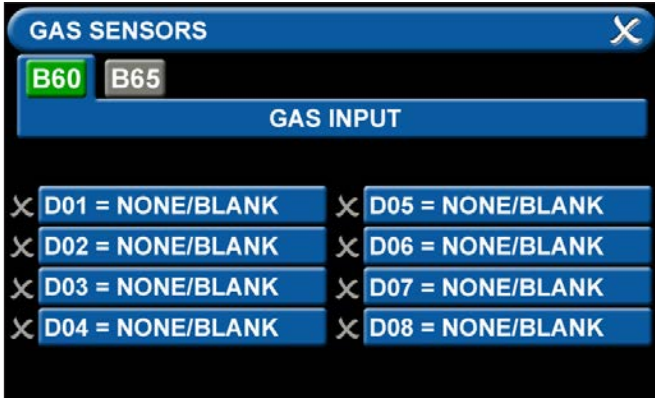

Figure 128: B60 Gas Input Screen

B60 Board

Users may select up to six different gases on the GAS INPUT screen. These gases correspond to the pressure sensors wired into the GAS INPUT / B60 board or the Gas Combination / B65 board.

Note: This setup accommodates:

- One master badge (with 10 source badges) and two area badges = three total badges
- One master badge (with 10 source badges) and four area badges = five total badges
- One master badge (with 10 source badges) and six area badges = seven total badges



Figure 129: Gas Choices

To select the first gas, touch the D01=NONE/BLANK tab.

- Touch the right and left arrows at the bottom of the screen to scroll through additional gas choices. Select the gas that is wired into the D01 input on the GAS INPUT / B60 board.
- Touch the Save button when you see a check beside your selection. (If an alarm sounds, press the Mute button on the panel under the screen and continue with setup.)
- Repeat to add additional gases.
- Touch the X button in the upper right to close the GAS SENSORS screen and return to the PRIMARY SETTINGS screen. The alarm will retain your information.

B65 Board

The GAS SENSORS screen defaults to the B60 board, so users will see a MODULE NOT INITIALIZED message.

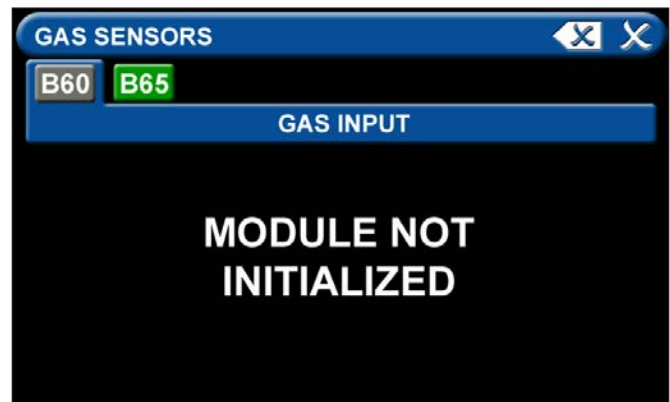

Figure 130: B60 Module not initialized

- Touch the B65 tab to go to the GAS COMBINATION screen.

TotalAlert Infinity™ NFPA Medical Gas Notification System



Figure 131: B65 Board

- Users may select up to three different gases on the GAS COMBINATION screen. These gases correspond to the pressure sensors wired into the GAS COMBINATION / B65 board.

Note: This setup accommodates:

- One master badge (with 10 source badges) and two area badges = three total badges
- One master badge (with 10 source badges) and four area badges (only three can be configured) = five total badges
- One master badge (with 10 source badges) and six area badges (only three can be configured) = seven total badges



Figure 132: B65 Gas Combination Screen

To select the first gas, touch the D01=NONE/BLANK tab.



Figure 133: Gas Choices

- Use the right and left arrows at the bottom of the screen to scroll through additional gas choices. Select the gas that is wired into the D01 input on the GAS COMBINATION / B65 board.
- Touch the Save button when you see a check beside your selection. (If an alarm sounds, press the Mute button on the panel under the screen and continue with setup.)
- The GAS COMBINATION screen will now display with the D01=[X] checked
- Repeat the above steps to select up to two additional gases.

NOTE:

See the end of this section for information on the Miscellaneous Tab. See section 4.6 for information on the Active Alarm Opt Tab.

4.5.4 Miscellaneous Tab

Users can customize certain aspects of the TotalAlert Infinity™ Alarm’s appearance and functionality. Two aspects of functionality that can be adjusted are the WIFI settings and the date and time settings.

- Touch the MISCELLANEOUS tab.



Figure 134: Miscellaneous Screen

- **Wireless Ethernet Settings Tab**

The WIRELESS ETHERNET SETTINGS screen allows for customization of the WIFI settings. All of the tabs on this screen are set to default status.

- Touch the WIRELESS ETHERNET tab.
- To turn the WIFI on, touch the WIFI STATUS / ON tab.
- To change the WIFI password—STRONGLY RECOMMENDED—touch the WIFI PWD tab. Using the keyboard, enter a new password. Touch the Save button to close and return to the WIFI SETTINGS screen.
- To add the WIFI settings to the INFORMATION screen, touch the ALLOW WIFI CONTROL / ON tab. Touch the Save button.
- The INFORMATION screen will now display a WIFI tab.

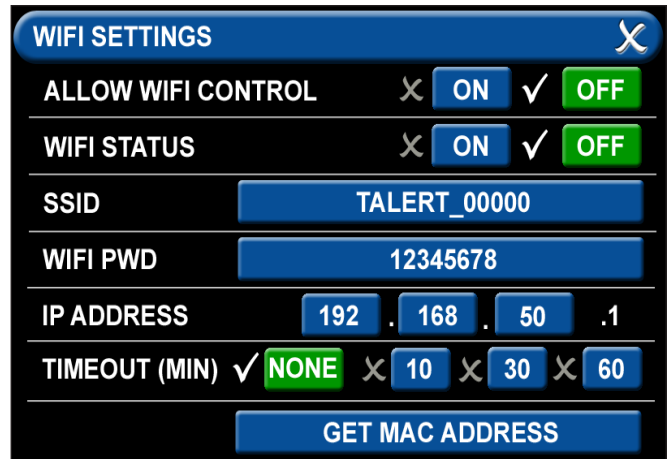

Figure 135: WIFI Settings Screen

The WIFI screen shows:

- WIFI status
- SSID
- IP address

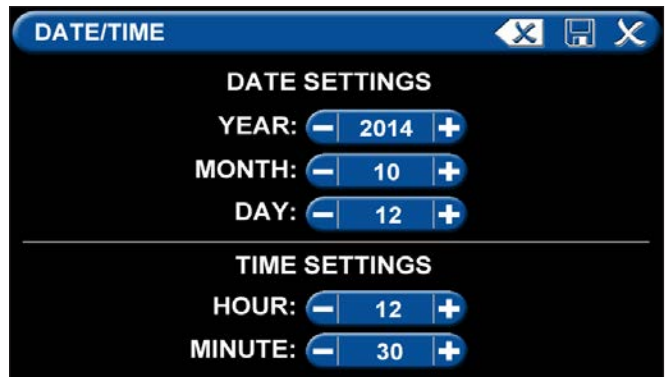

Figure 136: Date/Time Settings Screen

- **Date/Time Settings Tab**

For DATE SETTINGS, use the plus and minus signs to adjust the:

- Year
- Month
- Day

For TIME SETTINGS, use the plus and minus signs to adjust the 24-hour clock:

- Hour
- Minute

4.6 Customized Instructions Set Up

Active Alarm Opt Tab

The ACTIVE ALARM OPT tab allows users to customize their Active Alarm options in two ways: by adding alarm instructions and by changing the alarm default screen.

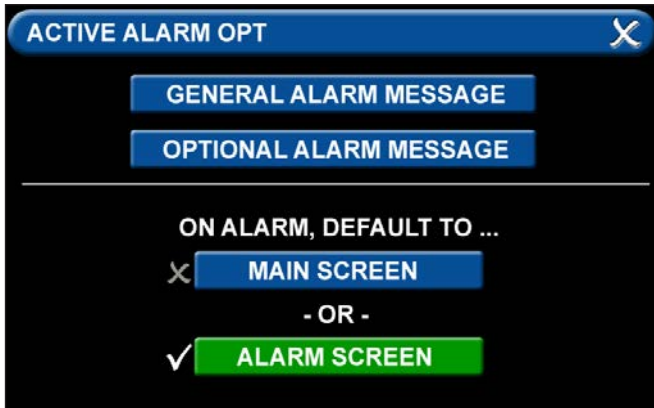

Figure 137: Active Alarm Opt Tab

- **Adding Custom Alarm Instructions**

Users can add instructions—both general instructions and specific instructions—to facility personnel for when the alarm goes into fault status.

To add general instructions:

- Touch the GENERAL ALARM MESSAGE tab
- Enter the instruction.



Figure 138: General Alarm Message Tab

Keyboard tips:

- Touch the [<ÁÑ] to toggle to symbols. Touch the [1AZ] key to toggle back to letters and numbers.
- As text is entered, the letters will decrease in size. This feature helps to accommodate a longer message.
- To add a second line of text, use the Enter button.
- Touch the Save button to close and return to the ACTIVE ALARM OPT screen

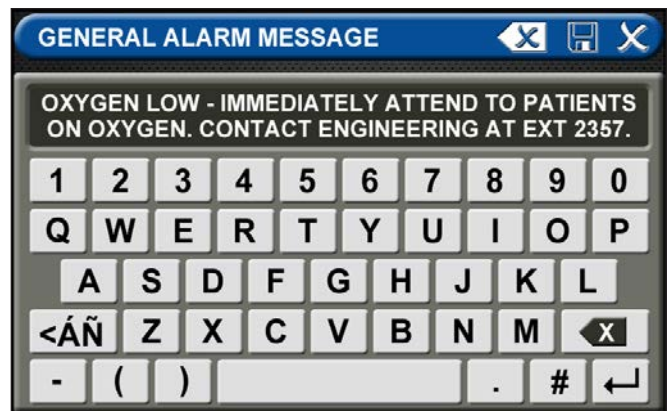

Figure 139: General Alarm Message Screen

To add specific instructions:

- Touch the OPTIONAL ALARM MESSAGE tab.

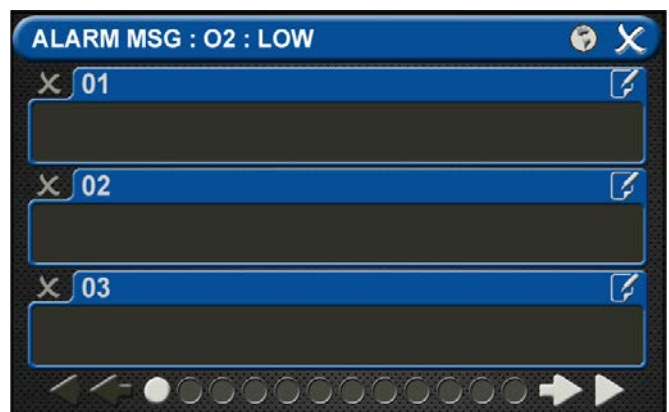

Figure 140: Alarm Messages Screen

TotalAlert Infinity™ NFPA Medical Gas Notification System

- Touch the 01 tab. Enter the instruction. Touch the [<ÁÑ] to toggle to symbols. Touch the [1AZ] key to toggle back to letters and numbers.

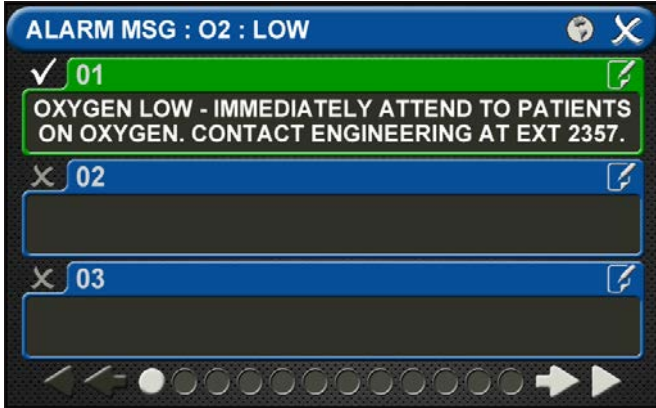

Figure 141: Optional Alarm Message

- Touch the Save button to close.
- Repeat to add additional instructions.
- Touch the X button to close and return to the ALARM MESSAGES screen.
- Touch the X button to close and return to the ACTIVE ALARM OPT screen.
- To tie an optional alarm message, or specific instruction, to a set point, go to the LOW ALARM SETTINGS screen or the HIGH ALARM SETTINGS screen for that gas
- Touch the OPTION MSG tab

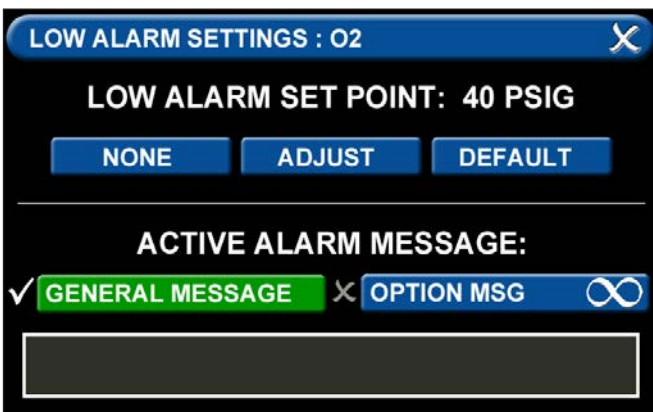

Figure 142: Low Alarm Settings

- Touch the X button to the left of the appropriate instruction tab. When your selection appears checked and highlighted, touch the Save button.
- This specific instruction (rather than the general instructions) will now display on the ACTIVE ALARM screen when the alarm is in fault status. It will also display on the ALARM POINTS screen.

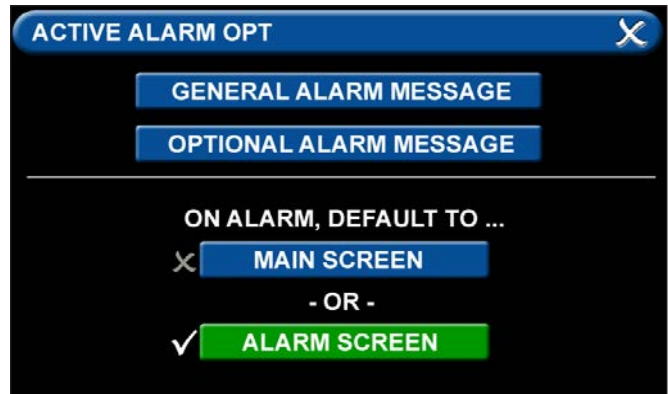

Figure 143: Alarm Message: High

- **Changing the Alarm Default Screen**
- The TotalAlert Infinity™ Area Alarm switches to the ACTIVE ALARM screen if the alarm goes into fault status.
- To configure the alarm so that the MAIN screen appears in the event of a fault, touch the MAIN screen tab.
- If the alarm is already displaying the MAIN screen when it goes into fault status, the toolbar will switch from Normal to Icon and the high or low pressure indicator on the gas badge will flash for the gas pressure out of range.

4.7 Additional Components

4.7.1 4-20 mA Devices

To configure a 4-20mA device for monitoring, start on the CONFIGURATION screen. Users are always prompted to enter the password when accessing this screen.

Type the password, and touch the Enter button.

The CONFIGURATION screen displays.



Figure 144: Configuration screen

The TotalAlert Infinity™ alarm is designed to allow configuration of four gas badges using the B50 board to monitor 4-20mA devices. The alarm must be set as an Area panel or Combination panel. See Alarm Type Tab in Section 4.3.2.

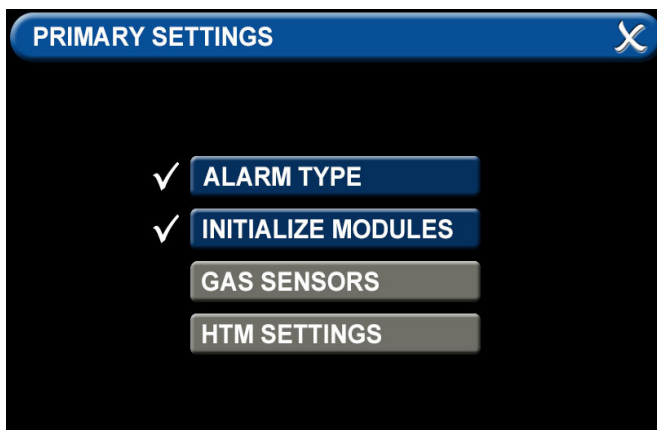

Figure 145: Primary Settings screen

After configuring the Alarm Type, the B50 board must be initialized. Select “Initialize Modules” on the Primary Settings Screen. Press the “Scan” button to make sure the B50 board is set up, as it should turn green. Once the B50 board is green, press the “Save” icon to exit the screen. Exit the “Primary Settings” screen.

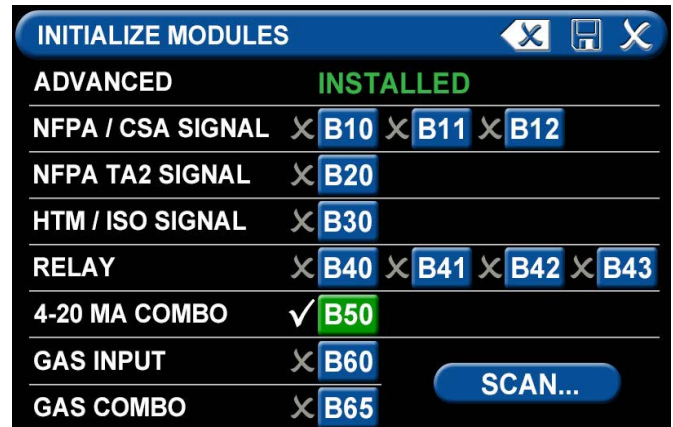

Figure 146: initialize Modules screen

To configure the first badge to custom settings, touch the corresponding number button in the numeric display that represents the badge to be configured. If a badge needs to be added, press the “+” for additional badges.

Eight tabs are used for configuration of a custom badge. Tabs are listed in alphabetical order.

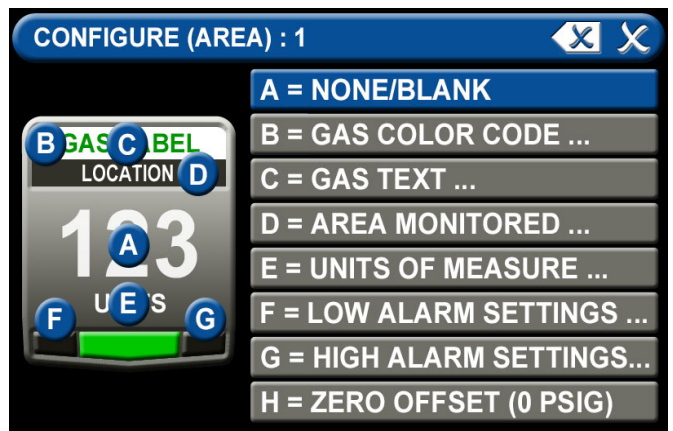

Figure 147: Configure Area screen

TotalAlert Infinity™ NFPA Medical Gas Notification System

A = [Gas Input] Tab

The B50 should be green and there should be 4 choices (I01, I02, I03, I04). Select the wired input to be displayed on that badge.

Touch the tab for the appropriate wired gas sensor.



Figure 148: B50 Tab, 4-20 mA

Touch the Save button to close the screen.

B = Gas Desc Tab

To assign a color code for the device:

1. Scroll through the codes using the right and left arrows at the bottom of the screen. Custom colors are located on pages 7-8.
2. Touch the tab for the appropriate code.
3. Touch the Save button when you see a check beside your selection.



Figure 149: Gas Color Code Tab

C = [Gas Name] Tab

Use the keyboard to assign a device name.

Type in the name of the device to be monitored. Touch the [<ÁÑ] to toggle to symbols and extended Latin Characters. Touch the [1AZ] key to toggle back to letters and numbers.

Touch the Save button when complete.



Figure 150: Gas Text Keyboard

D = Area Monitored Tab

To add locations to be monitored:

1. Touch an unused location tab.
2. Using the keyboard, enter the name of the location that you would like to monitor (e.g., ROOM 1). Enter multiple locations as needed (e.g., Room 1, Room 2, Room 5).
3. A check appears when the location is selected, the save button has to be pressed if the selection is new.

To edit the location information, touch the Pencil button.



Figure 151: Source Location

E = [Units of Measure] Tab

To set up the 4-20mA device:

1. Touch the tab for “4MA=” to set the low measurement point of the device (zero for example) and press the save button to exit.
2. Touch the tab for “20MA=” to set the high measurement point of the device (100 for example) and press the save button to exit.
3. Touch the tab for “Units=” to set the method of measurement (percent for example), type in the measurement type and press the save button to exit.
4. Touch the X button in the upper right to close the screen.

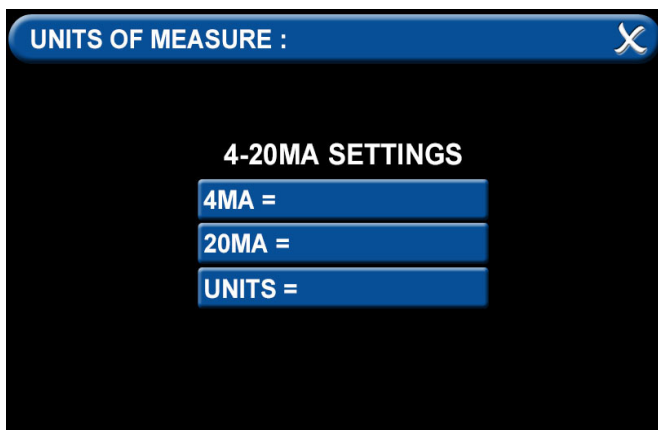

Figure 152: Units of Measure Tab

F = Low Alarm Settings Tab

You can remove the low alarm set point or customize the low alarm set point.

To remove the low alarm set point:

1. Touch the NONE tab.
2. Touch the check on the CONFIRM SETTINGS CHANGE screen.

To customize the low alarm set point:

1. Touch the ADJUST tab.
2. Enter the new set point.
3. Touch the Save button.

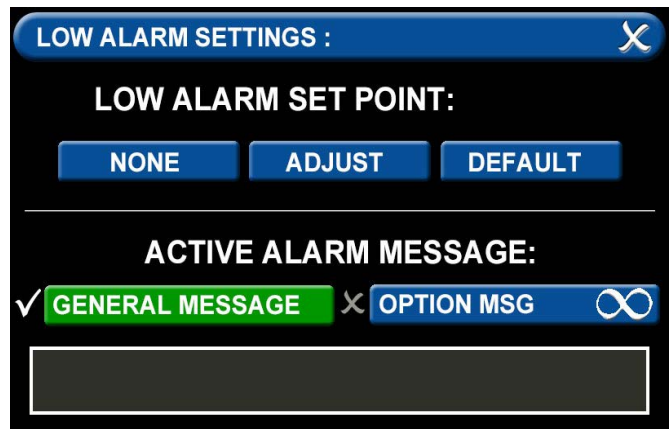

Figure 153: Low Alarm Settings

G = High Alarm Settings Tab

You can remove the high alarm set point or customize the high alarm set point.

To remove the high alarm set point:

1. Touch the NONE tab.
2. Touch the check on the CONFIRM SETTINGS CHANGE screen.

To customize the high alarm set point:

1. Touch the ADJUST tab.
2. Enter the new set point.
3. Touch the Save button.

TotalAlert Infinity™ NFPA Medical Gas Notification System

Active Alarm

To setup active alarm General Message:

1. Touch the General Message tab to activate general message.
2. Touch the gray text box at bottom of screen to type in general message.
3. Using the keyboard, enter the message that you would like to be active when in alarm mode and save.

To setup active alarm Option Message:

1. Touch the Optional Message tab to activate optional message.
2. Touch the 01 tab.
3. Using the keyboard, enter the optional message that you would like to be active when in alarm mode and save.

Configuring Additional 4-20mA Devices

Configure additional 4-20mA devices by touching the number on the numeric display that corresponds with the gas badge and repeating the steps listed above.

4.7.2 Relay Output Board (B4X Board)

To configure a Relay Output, start on the CONFIGURATION screen. Users are always prompted to enter the password when accessing this screen.

Type the password, and touch the Enter button.

The CONFIGURATION screen displays.



Figure 154: Configuration Screen

The B40 (or B41, B42, B43) board must be initialized. Touch Primary Settings from the right side menu, then select “Initialize Modules”. Press the “Scan” button to make sure the B40 board is set up, as it should turn green. Once the B40 board is green, press the “Save” icon to exit the screen. Exit the “Primary Settings” screen.



Figure 155: Initialize Modules Screen

The next step is to select the “Relay Outputs” from the menu on the Configuration Screen. The B40 board should be highlighted in Green (or other Relay Output board installed in the rough-in box).

Select the signal that corresponds to the output wires on the relay board (Y01 for example).



Figure 156: Relay Outputs Screen

After selecting the signal, you will need to assign it to an alarm signal to send. Select “Wired” on the Relay Output screen if the signal to be relayed is wired into the rough-in box.

TotalAlert Infinity™ NFPA Medical Gas Notification System

Select the corresponding “Ethernet” if an Ethernet signal has been set up. (See Mirroring in Section 4.6.4.

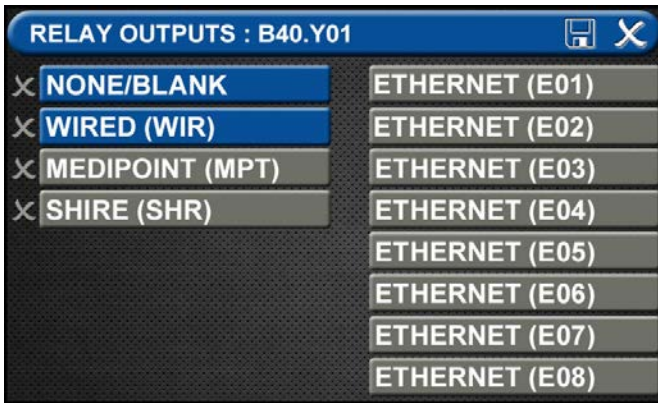

Figure 157: Relay Output Signal

There are four choices for the relay output signal.

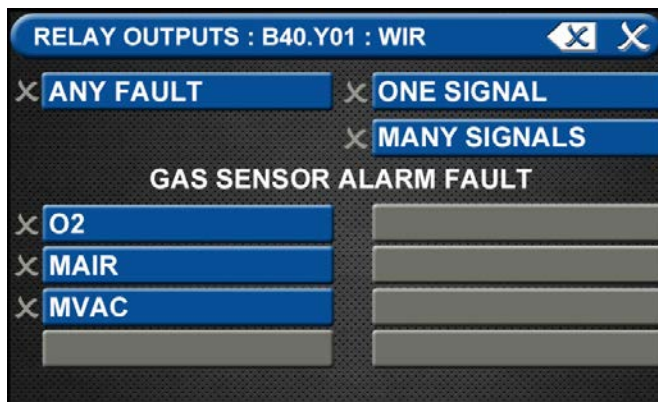

Figure 158: Relay Output Signals Screen

1. A single “Any Fault” which will report a general alarm fault if any of the alarm signals on the alarm go into alarm condition. To select “Any Fault”, press the blue “Any Fault” to change it to green with the check mark. Then press Save to return to Relay Outputs and set up additional outputs.
2. “One Signal” reports a single signal through the relay output. When pressing “One Signal”, the next step is to assign the signal to be transmitted. On the Relay Output screen, select the Input Signal to be transmitted (X01 from the B10 board for example). Press Save to return to the Relay Outputs screen.



Figure 159: Relay Output One Signal

3. “Many Signals” allows the user to group multiple signals on a single relay output. If any of the signals goes into alarm condition, the relay output will report an alarm condition. Press “Many Signals” to move to the Relay Output screen and select from 1 to 10 signals to group together. Select the number 01 to start, then select the first signal to be grouped by pressing the corresponding number on the Relay Output (such as X01 from the B10 board). Press Save to return to the Many Signal Relay Output screen. Next select 02 to capture the second signal to be monitored. Repeat up to a grouping of 10 signals.



Figure 160: Relay Output Many Signals

4. “Gas Sensor Alarm Fault” allows the user to report a fault condition based on a gas sensor through the relay output. When choosing Gas Sensor Alarm Fault, select the gas sensor to be monitored from the list. Press Save to return to the Relay Outputs screen.

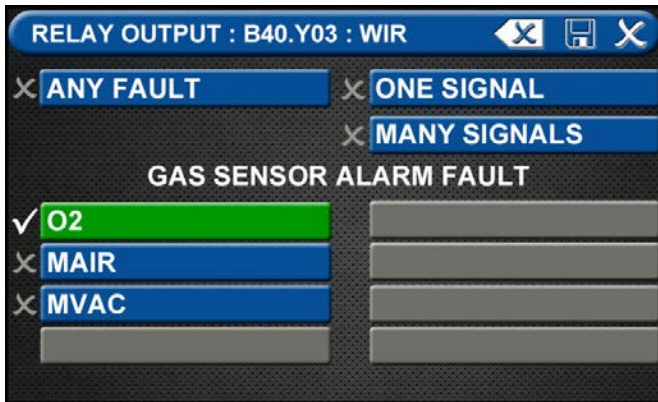

Figure 161: Gas Sensor Alarm Fault

4.7.3 Wired Ethernet Setup

The TotalAlert Infinity™ Notification System allows for networking via standard Ethernet. Any alarm panel can be remotely observed on the network using a standard web browser.

IP Address using DHCP method: Upon power-up of the system, the device will search for a DHCP server. If a DHCP server is found, IP Address, subnet mask and gateway are automatically obtained. If not found, the device will check for a DHCP server every 30 seconds. When found, the IP Address, subnet mask and gateway are automatically obtained.

IP Address using Static method: Upon power up of the system, the device will immediately begin using the fixed IP configuration.

CAUTION:

Only facility information systems personnel should set up the network interface. If the set up is done improperly, equipment may not perform properly.

CAUTION:

The information systems personnel should be notified before changing any of the network settings. Changing the settings could keep the equipment from working properly.

Wired Ethernet Settings

On the Miscellaneous screen, touch the WIRED ETHERNET tab (Figure 162).



Figure 162: Miscellaneous Screen

The WIRED ETHERNET screen allows for customization of the Ethernet settings. All of the tabs on this screen are set to default status.

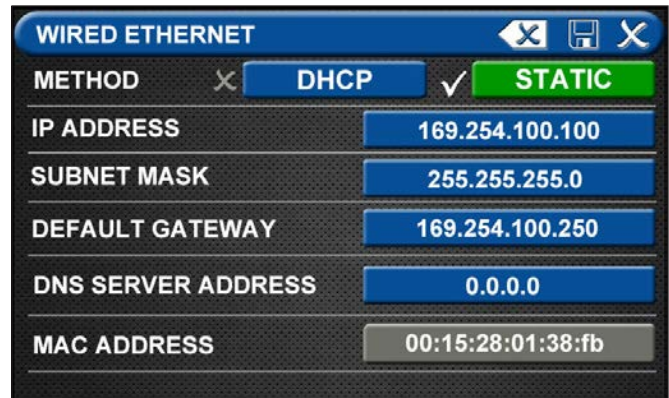

Figure 163: Wired Ethernet Screen

- The alarm IP Address defaults to Static method. To select the DHCP method, touch the DHCP tab.
- To change the IP Address, touch the IP Address tab. Using the keyboard, enter a new IP address.
- To change the Subnet Mask, touch the Subnet Mask tab. Using the keyboard, enter a new Subnet Mask address.
- To change the Default Gateway, touch the Default Gateway tab. Using the keyboard, enter a new Default Gateway.
- To change the DSN Server Address, touch the DSN Server Address tab. Using the keyboard, enter a new DSN Server Address.

4.7.4 BACnet Set-Up

The TotalAlert Infinity™ alarms employ the TCP/IP family of protocols for communication and each device has a unique IP address. The alarm utilizes a built-in Ethernet connection for BACnet transmission of signals to a Building Automation System. The TotalAlert Infinity™ alarm panel conforms to the BACnet protocol and includes a Protocol Implementation Conformance Statement (PICS).

- Touch the MISCELLANEOUS tab located on the configuration screen.



Figure 164: Configuration Screen

- Touch the BACNET tab to access the BACNET control screen.



Figure 165: Miscellaneous Screen

- To allow BACnet communication, touch the BACnet ON tab.
- To add the name, touch the DEVICE NAME tab and enter the name through the on screen keyboard.

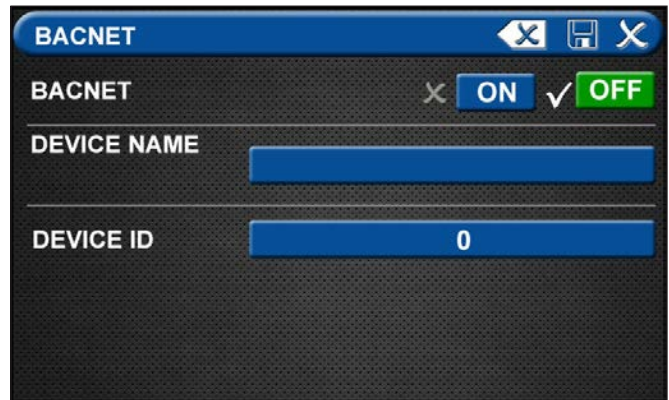

Figure 166: BACnet Screen

- Save the BACnet device name by touching the save button located in the top right corner of the screen.



Figure 167: BACnet Device Name

- To add the ID, touch the DEVICE ID tab and enter the ID number provided by the Building Management System administrator.



Figure 168: BACnet Device ID

- Save settings.
- Touch the X in the top right corner to exit out of the BACnet setup screen.

TotalAlert Infinity™ NFPA Medical Gas Notification System

4.7.5 “Mirroring” Two Alarm Panels

Each alarm panel has an Ethernet port on the back of the front panel assembly. By connecting the alarm to the hospital network, via Ethernet, or directly cabling it to another alarm panel, signals and gas pressures can be pulled from one panel and displayed on another panel

An category 5 CROSS OVER cable is required for connecting alarm panels directly to each other. Otherwise, standard cabling can be used with a facility’s Ethernet hub or switch to connect panels.

Setup of alarm to be “mirrored”

Start on the Configuration screen.

- Enter Security Password



Figure 169: Security Password

- Touch the MISCELLANEOUS tab located on the setup screen

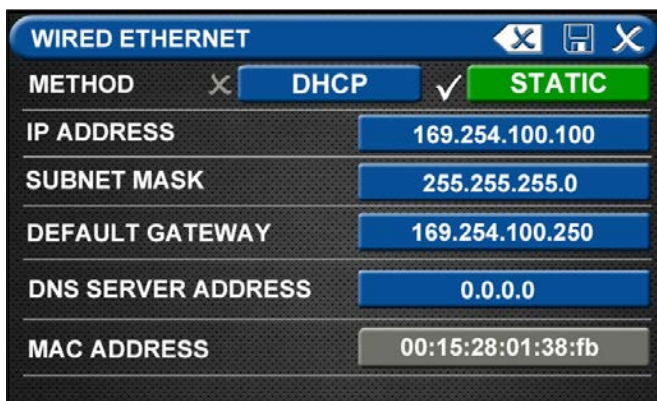

Figure 170: Wired Ethernet Control Screen

- Touch Wired Ethernet tab to access the Wired Ethernet control screen (Section 4.7.3).
- Configuration of the Wired Ethernet settings to be performed by facility’s IT specialist. Settings for the IP Address, Subnet Mask, Default Gateway, and DNS Server Address to conform to facility’s network.
- Touch the Save button to close and return to the MISCELLANEOUS Screen.
- Exit the MISCELLANEOUS screen and return to the Configuration screen.



Figure 171: Configuration Screen

- Touch the REMOTE SIGNALS tab.

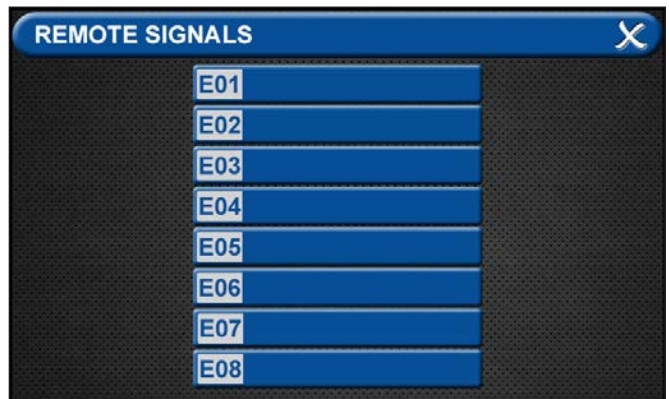

Figure 172: Remote Signals Screen

Each alarm panel can mirror signals and pressures from up to 8 remote alarm panels.

- Touch the E01 tab.
- Enter the Remote Ethernet IP address of the alarm panel to be mirrored.
- Touch the save button.

TotalAlert Infinity™ NFPA Medical Gas Notification System

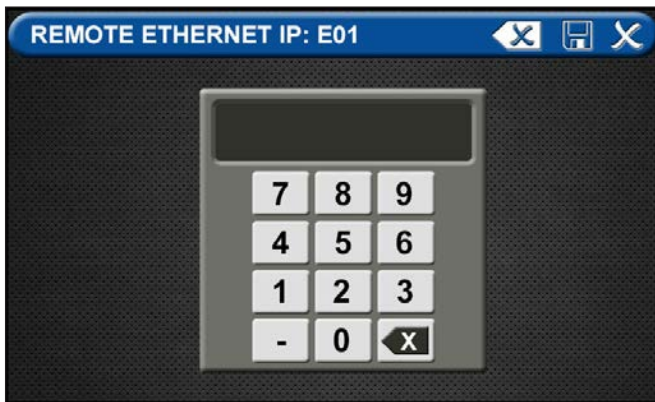

Figure 173: Remote Ethernet IP Address

On the alarm panel that will display the mirrored signal or pressure:

Gas Badge

- Go to Configuration screen



Figure 174: Configuration Screen

- Add new badge to be mirrored by touching the [+] key.
- Touch the badge number to be configured.
- On the CONFIGURE (AREA) screen, touch A=None/Blank tab to set up badge.

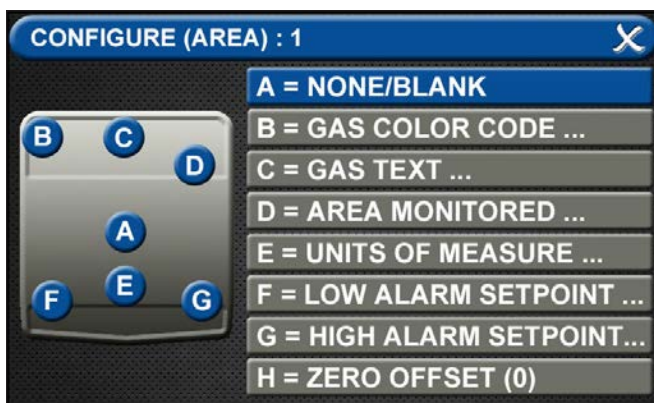

Figure 175: Configure Area Screen

- Touch the ETHERNET tab that corresponds to the alarm panel providing the gas pressure to be mirrored.

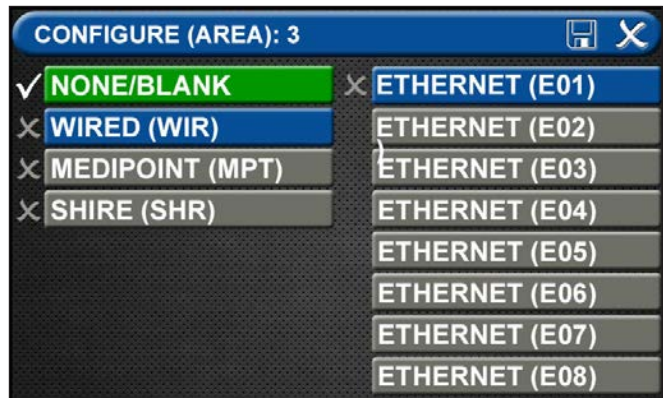

Figure 176: Ethernet Screen

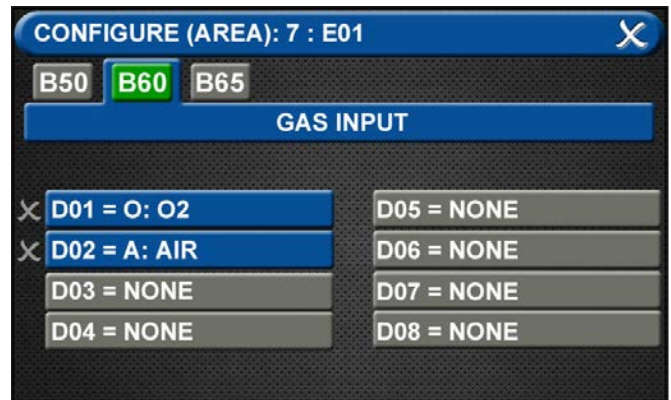

Figure 177: Configure Area Screen

- At the CONFIGURE (AREA) screen (B60 Gas Input), touch the gas to be mirrored.
- Touch the save button.
- Follow the steps for configuring gas badges listed in Section 4.3.

TotalAlert Infinity™ NFPA Medical Gas Notification System

Master Signals

- Go to the Configuration screen



Figure 178: Configuration Screen

- Choose the consolidated gas badge that represents the source gas to be mirrored.
- Touch the LOCATIONS tab for the gas that will be mirrored.

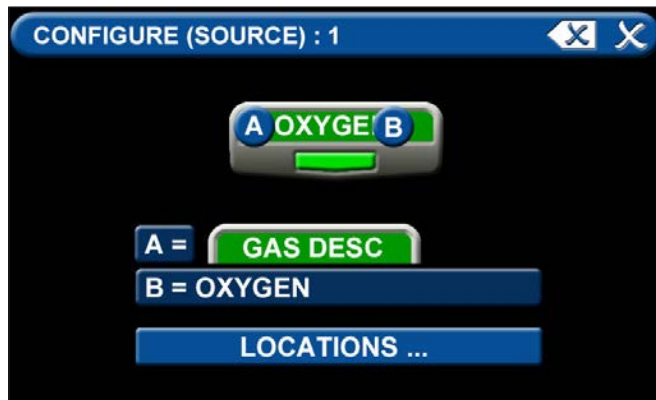

Figure 179: Configure Source Locations

- Add a new location by touching the [+] tab.

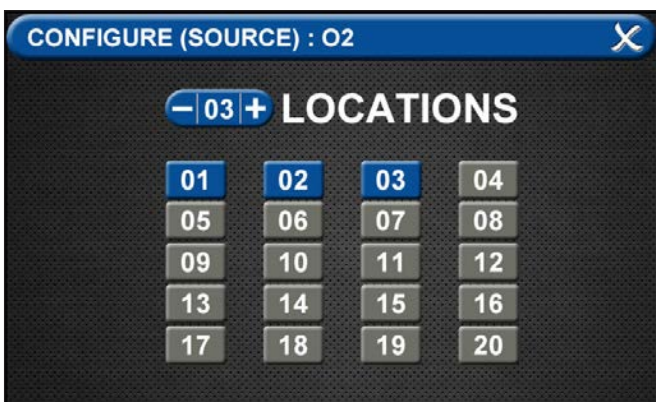

Figure 180: Locations Screen

- Touch the new location tab to return to the configure source screen.
- To add another location, touch the LOCATION tab and choose an existing location or type in a new source location (Figure 181).
- Touch the save button.
- To set an alarm point, touch the ALARM POINT tab (Figure 181).

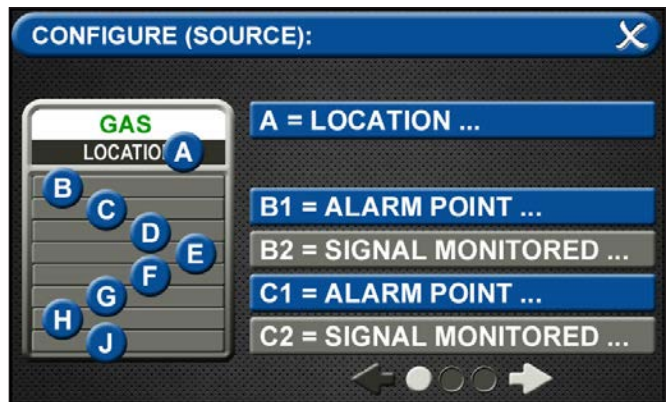

Figure 181: Configure Source Screen

- Touch the ETHERNET tab that corresponds to the alarm panel providing the source signal to be mirrored (Figure 182).

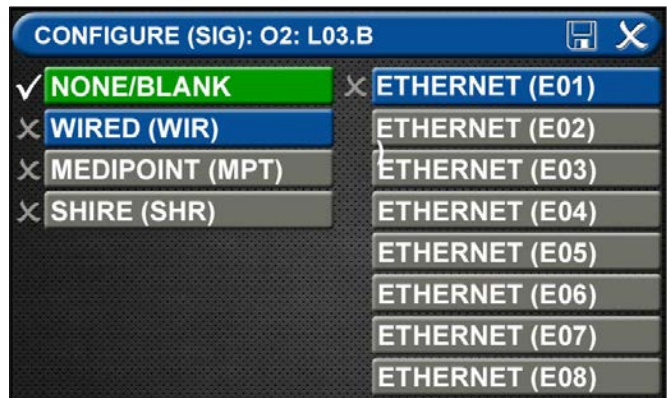

Figure 182: Ethernet Screen

TotalAlert Infinity™ NFPA Medical Gas Notification System

- From the Configure Sig screen, touch the tab that represents the wire landing location for the signal on the originating panel.
- Touch the tab for the appropriate board and terminal block.

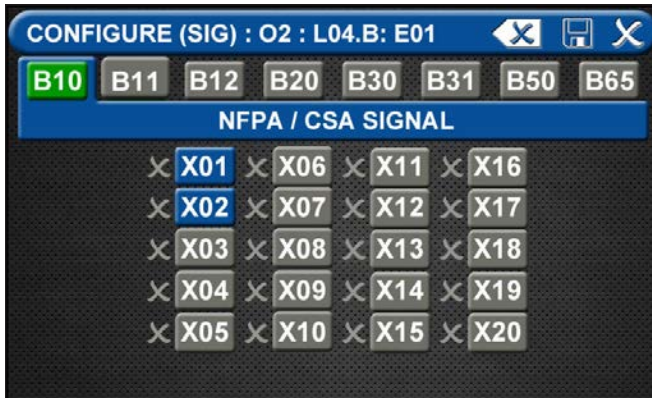

Figure 183: Configure Sig Screen

- Touch the Save button when you see a check beside your selection. This should go automatically to the SIGNAL SETTINGS screen.
- Touch the NONE/BLANK tab.

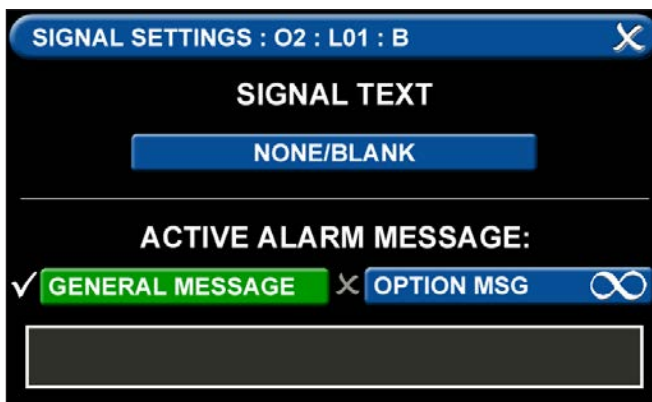

Figure 184: Signal Settings Screen

- To select source signal input text:
- Scroll through the options using the right and left arrows at the bottom of the screen.
 - Touch the tab for the appropriate option.
 - Touch the Save button when you see a check beside your selection to close and return to the SIGNAL SETTINGS screen.
 - Touch the X button in the upper right to close and return to the CONFIGURE (SOURCE) screen.

4.8 Website

4.8.1 Navigating the Website

Accessing the Web Page

1. Start a web browser such as Microsoft Internet Explorer.
2. Enter the Device's IP address in the browser's address bar:
Example: http://10.10.5.10
3. After you enter the device name or IP address, the alarm's home page will be displayed.

NOTE:

To learn the IP address, touch the MISCELLANEOUS tab on the configuration screen then touch the WIRED ETHERNET tab.

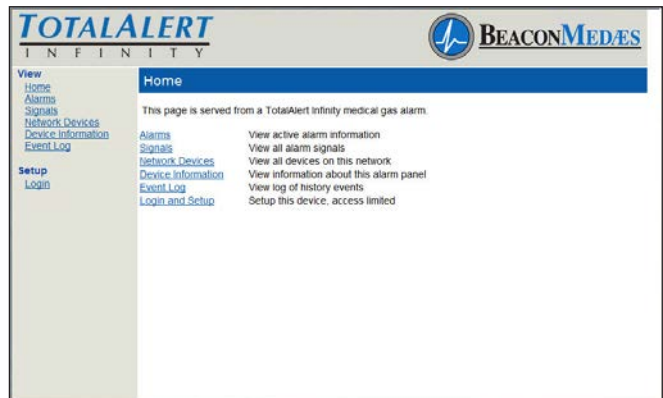

Figure 185: Typical Alarm Panel Home Page

TotalAlert Infinity™ NFPA Medical Gas Notification System

Alarms

1. Click Alarms to view current alarms (Figure 186).
2. Click Refresh to view the most recent information.

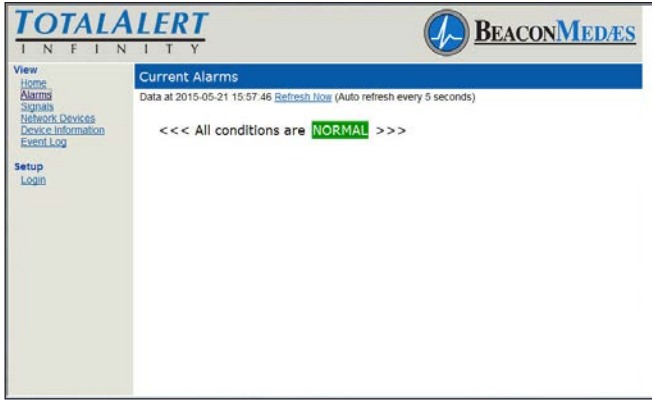

Figure 186: Alarms Page

NOTE:

The Alarms page provides a snapshot of the current alarm conditions. If a new alarm occurs, the page is not updated until the page is reloaded by Autorefresh or by clicking on Alarms or Refresh links.

Signals

1. Click Signals to view all local signals monitored by this alarm panel (Figure 187).
2. Click Refresh to view the most recent information

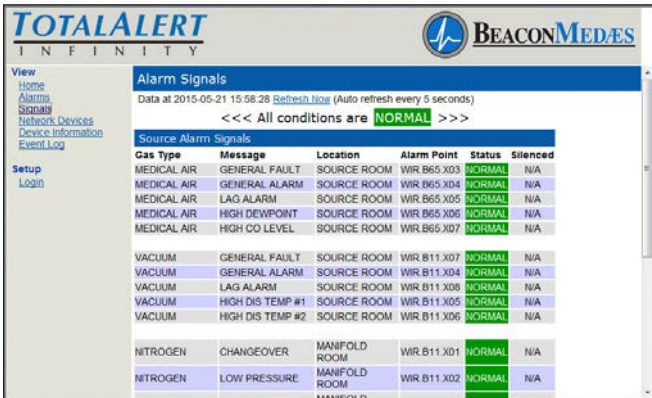

Figure 187: Alarm Signals Page

NOTE:

The Signals page provides a snapshot of the current alarm conditions. If a new alarm occurs, the page is not updated until the page is reloaded by Autorefresh or by clicking on Signals or Refresh links.

Network Devices

1. To view all devices on the network, click Network Devices (Figure 188).
2. Click Refresh to view the most recent information.
3. Click the Device link to jump to the home page of the listed alarm.
4. Click the Details tab to show detailed information about the device.

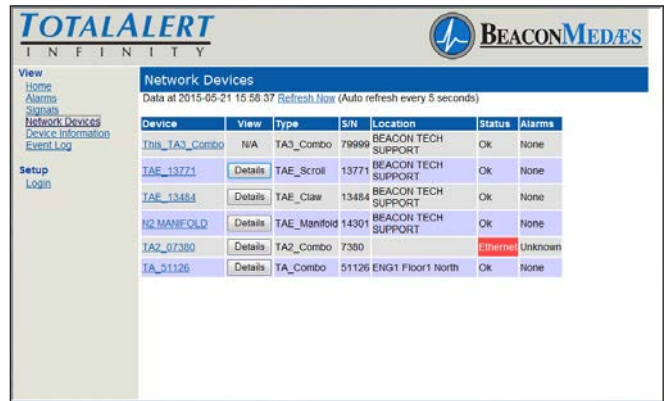

Figure 188: Network Devices Page

NOTE:

The Network Devices page provides a snapshot of the current alarm network. If a device is added to the network the page is not updated until the page is reloaded by Autorefresh or by clicking on Network Devices or Refresh links.

TotalAlert Infinity™ NFPA Medical Gas Notification System

Device Information

1. Click Device Information to view the Device Information page (Figure 188).

Event Log

1. Click Event Log to view the Event Log page (Figure 189).
2. Click Refresh to view the most recent information.
3. To create a downloadable text file, click the Create a Downloadable text file link.
4. Right click the link to save the event log to a file.

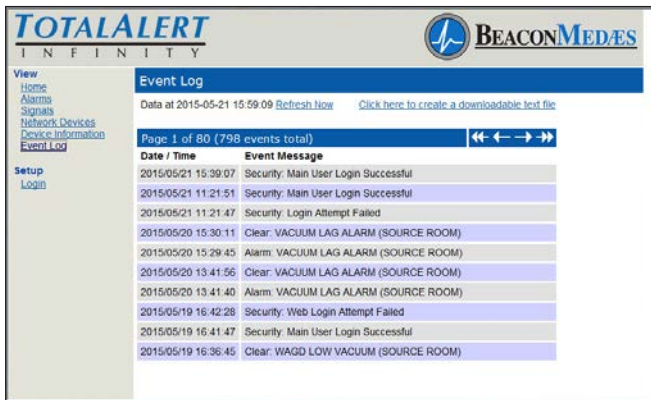

Date / Time	Event Message
2015/05/21 15:39:07	Security: Main User Login Successful
2015/05/21 11:21:51	Security: Main User Login Successful
2015/05/21 11:21:47	Security: Login Attempt Failed
2015/05/20 15:30:11	Clear: VACUUM LAG ALARM (SOURCE ROOM)
2015/05/20 15:29:45	Alarm: VACUUM LAG ALARM (SOURCE ROOM)
2015/05/20 13:41:55	Clear: VACUUM LAG ALARM (SOURCE ROOM)
2015/05/20 13:41:40	Alarm: VACUUM LAG ALARM (SOURCE ROOM)
2015/05/19 16:42:28	Security: Web Login Attempt Failed
2015/05/19 16:41:47	Security: Main User Login Successful
2015/05/19 16:36:45	Clear: WAGD LOW VACUUM (SOURCE ROOM)

Figure 189: Event Log

NOTE:

The Event Log page provides a snapshot of the event log. If a new event occurs the page is not updated until the page is reloaded by Autorefresh or by clicking on Event Log or Refresh links. **Maximum number of logged events is 1000.**

4.8.2 Website Set-Up

Accessing the Web Page

1. Start a web browser such as Microsoft Internet Explorer.
2. Enter the Device's IP address in the browser's address bar:
Example: `http://10.10.5.10`

NOTE:

To learn the IP address, touch the MISCELLANEOUS tab on the configuration screen then touch the WIRED ETHERNET tab.

3. After you enter the device name or IP address, the alarm's home page will be displayed (Figure 190).

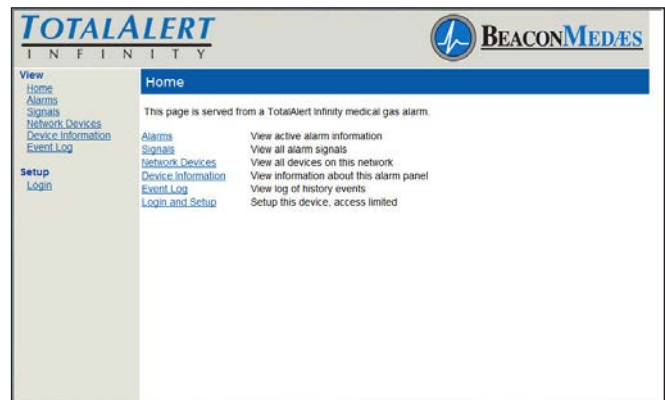

View	Home
Home	This page is served from a TotalAlert Infinity medical gas alarm.
Alarms	View active alarm information
Signals	View all alarm signals
Network Devices	View all devices on this network
Device Information	View information about this alarm panel
Event Log	View log of history events
Setup	Setup this device, access limited
Login	

Figure 190: Typical Alarm Panel Home Page

Login to Setup Pages

1. Click Login and Setup.
2. The web browser will request a username and password (Figure 191). The factory defaults are:
Username: TotalAlert
Password: 121212

NOTE:

If the on-screen password has been changed from the default password, use the newly assigned password.

TotalAlert Infinity™ NFPA Medical Gas Notification System

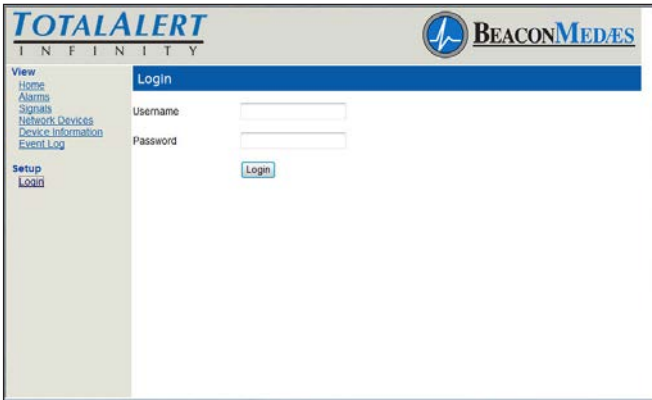

Figure 191: Login Dialog

3. The left sidebar will now contain the setup links (Figure 192).

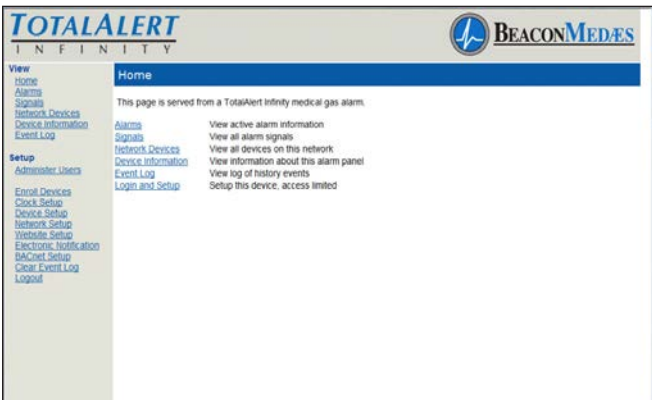

Figure 192: Logged In

NOTE:

Logging in applies only to the computer on which the login occurs. If more than one PC is being used to access the alarm web pages, each one must be logged in individually. The computer stays logged in until the user closes the browser.

Administer Users

Each TotalAlert Infinity™ panel allows for three total Administer Users

1. Click on Administer Users to access the Administer Users Setup page (Figure 193)
2. Enter the User Name and Password then click Submit.

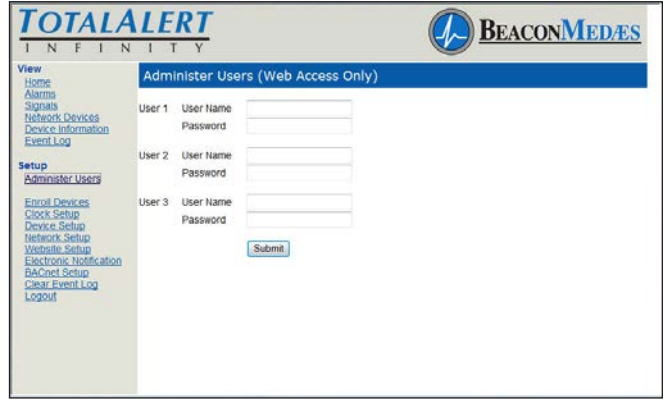

Figure 193: Administer Users

Enroll Devices

The TotalAlert Infinity™ provides the ability to enroll up to 100 TotalAlert Embedded devices connected to the medical gas network. Master and combination alarms are the only alarms that allow for enrolled devices. TotalAlert Infinity™ area alarms can now be enrolled via Ethernet to the TotalAlert Infinity™ master alarm. This allows for the user to see the fault condition (gas type and pressure reading) and which area panel the condition is for.

1. Click on Enroll Devices to access the Enroll Devices Setup page (Figure 194).
2. Enter the device IP address and Serial Number. The Device Name, Location, and Device Type will automatically fill (Network will refresh).
3. Click Submit.
4. To delete an enrolled device, click Del box of device to delete and click Submit.

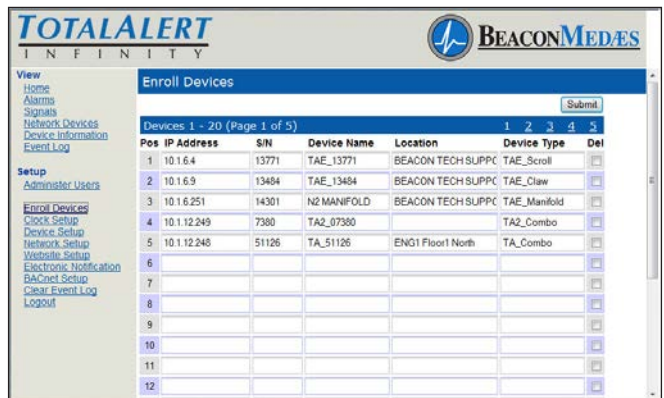

Figure 194: Enroll Device Setup

TotalAlert Infinity™ NFPA Medical Gas Notification System

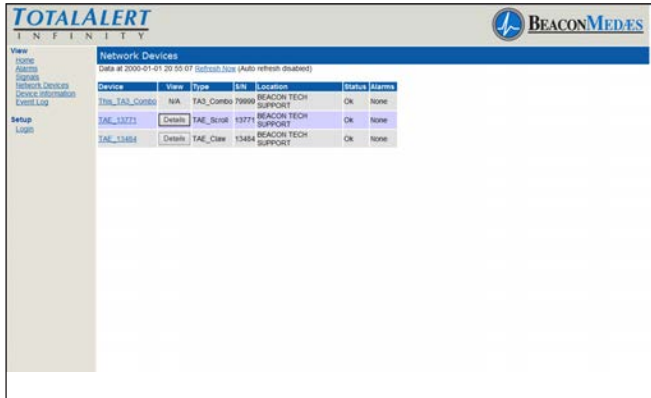

Figure 195: Network Devices Screen

Set Clock

1. Click Clock Setup to access the Clock Setup page (Figure 196).
2. Set the current date by inputting the year, month, and day.
3. Set the current time by inputting the current hour and minutes.
4. Click the SET tab to complete. When the SET tab is pressed, the date and time are set on the system and seconds are set to zero.



Figure 196: Clock Setup

Device Setup

This setup page is used to configure alarm name, location, facility name, and contact information. The page also provides input for TotalAlert1 compatibility if the TotalAlert Infinity™ needs to be enrolled on the TotalAlert 1 network.

1. Click Device Setup to access the Setup Device page (Figure 197).
2. Enter the Alarm name.
3. Enter the location.
4. Enter the facility name.
5. Enter the Contact Information.
6. Click Submit.

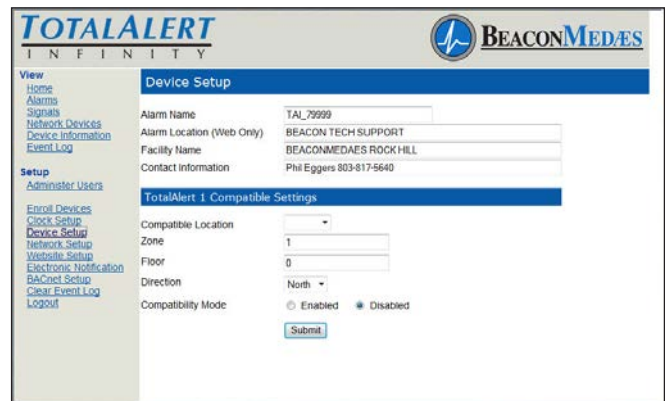

Figure 197: Setup Device Page

To provide input for the TotalAlert 1 network:

1. Click Device Setup to access the Setup Device page (Figure 197).
2. Select Compatible Location of the TotalAlert Infinity™ alarm by using pull down menu.
3. Enter the Zone for the TotalAlert Infinity™.
4. Enter Floor location.
5. Enter Direction.
6. Enter Compatibility Mode.
7. Click Submit.

Network Setup

CAUTION:

The Information Systems personnel should be notified before changing any of the network settings. Changing the settings may prevent the equipment from working properly.

1. Click Network Setup to access Network setup page (Figure 198).
2. Select the DHCP Mode (Enabled/Disabled).

If Disabled:

1. Enter the IP Address.
2. Enter the Subnet Mask.
3. Enter the Default Gateway

TotalAlert Infinity™ NFPA Medical Gas Notification System

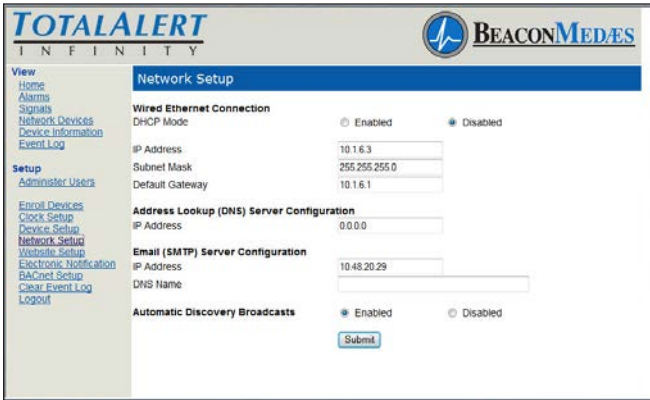

Figure 198: Network Setup Page

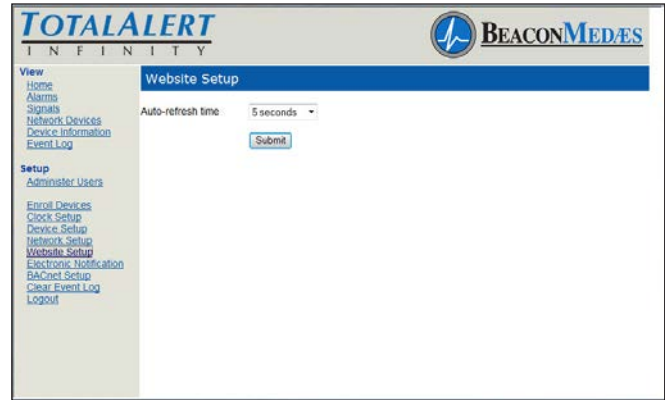

Figure 199: Website Setup Page

The TotalAlert Infinity™ Alarm allows for Automatic Discovery Broadcast on other TotalAlert devices. This setting allows for other TotalAlert devices to find the TotalAlert Infinity™ alarm on the network and automatically enroll the device.

To enable Automatic Discovery:

1. Select Enabled on the Network Setup page to set Automatic Discovery Broadcasts.
2. Click Submit.

Website Setup

The TotalAlert Infinity™ Website has several options for the Auto-refresh feature on the web page. This determines the frequency by which Status pages are automatically updated.

1. Click Website Setup to access Auto-refresh time menu (Figure 199).
2. Choose increments from 5 seconds to 4 minutes to refresh. Select Disable to remove Auto-refresh and manually update data when needed.
3. Click Submit.

Electronic Notification

This setup page is used to configure electronic notification (e-mail, pager, phone text message). The alarm panel acts as an SMTP client. An SMTP server is required for electronic notification to function. The TotalAlert Infinity™ website has the ability to setup email notification for all messages, all gases, or specifically up to 3 gases.

By setting up the Electronic Notification, key personnel can receive notifications of all alarm events.

An SMTP e-mail server must be configured in order for Electronic Notifications to function. Click “Set Up Email Server” to configure the server (Figure 200).

1. Click Electronic Notification to access the Electronic Notification setup page (Figure 200).
2. Enter an e-mail address. Up to twelve e-mail addresses can be set up.
3. Choose All Messages, All Gases, or Specific Gases (up to 3) from pull down menu.
4. Click Submit.

TotalAlert Infinity™ NFPA Medical Gas Notification System

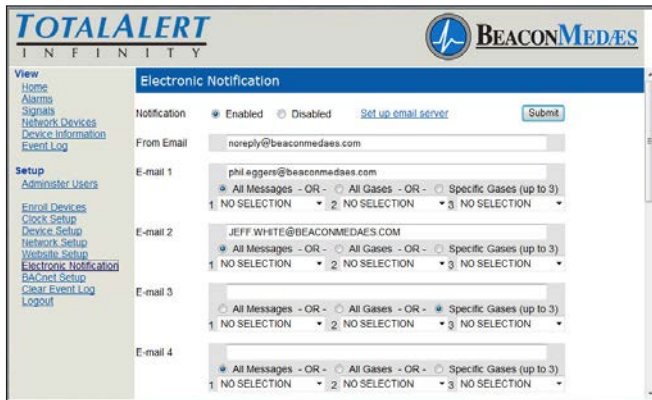

Figure 200: Electronic Notification Setup Page

BACnet Setup

The BeaconMedæx TotalAlert Infinity™ NFPA control systems utilize the TCP/ IP family of protocols for communication and each alarm has a unique IP address.

Each BACnet enabled TotalAlert Infinity™ alarm conforms to the BACnet protocol.

- Protocol Implementation Conformance

Each BACnet enabled TotalAlert Infinity™ alarm has available a Protocol Implementation Conformance Statement (PICS). The PICS is a written document created by BeaconMedæx that identifies the particular options specified by BACnet that are implemented in the TotalAlert Infinity™ alarm.

- BACnet Conformance

BACnet Vendor ID: 543

Alarm Profile: BACnet Smart Sensor (B-SS) BIBB (BACnet Interoperability Building Blocks) Supported:

- Read Property - B (DS-RP-B)
- Dynamic Device Binding - B (DM-DDB-B)
- Dynamic Object Binding - B (DM-DOB-B)

Object Type Support: Analog value, Binary value, Device.

Data Line Layer Options: ISO 8802-3 (“Ethernet”) LAN Character Set Support: ISO 10646 (UTF-8) Encoding.

1. Click BACnet Setup to access BACnet Setup page (Figure 201).
2. Enter BACnet Device ID#.
3. Enter BACnet Device Name.
4. Choose to Enable or Disable BACnet Communication.
5. Click Submit

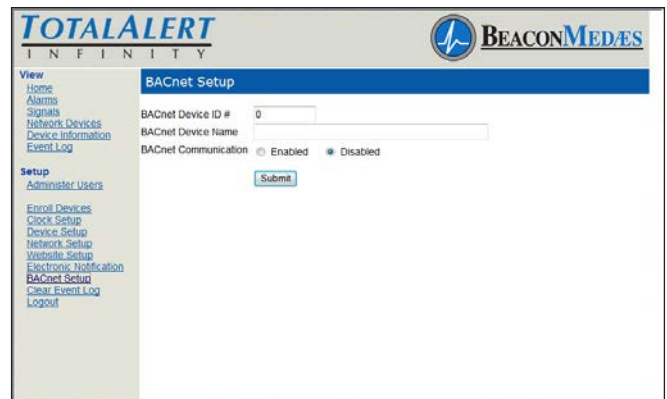

Figure 201: BACnet Setup Page

Clear Event Log

1. Click Clear Event Log to access the Clear Event Log page (Figure 202).
2. Click Clear Event Log.

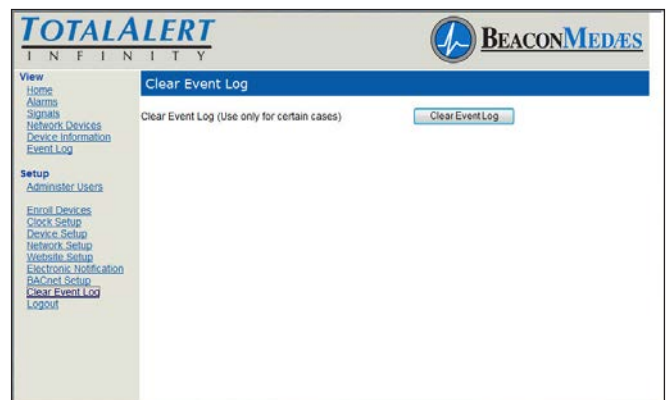

Figure 202: Clear Event Log

CAUTION:

Be sure to save the event log prior to clearing it. It is impossible to recover the event log after it is cleared.

4.9 Wireless Ethernet Set-Up

The TotalAlert Infinity™ Medical Gas Notification System allows for Wifi 802.11 b/g/n interface which provides access to the alarm panel web page with any web enabled device. Operating information and Event History can be viewed and downloaded to the web enabled device.

Wireless Ethernet Settings Tab

On the Miscellaneous screen, select the WIRELESS ETHERNET tab.



Figure 203: Wireless Ethernet Tab

The WIRELESS ETHERNET screen allows for customization of the WIFI settings. All of the tabs on this screen are set to default status.

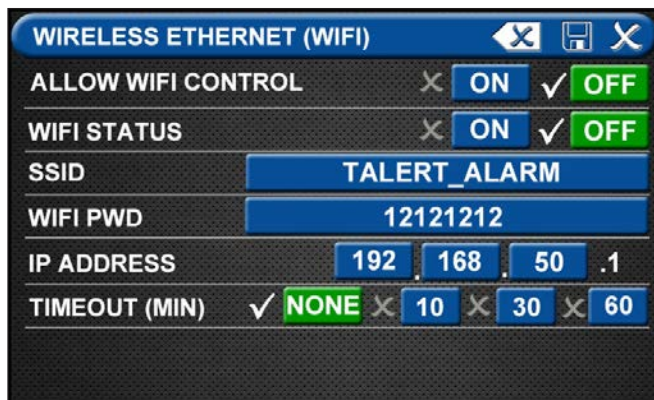

Figure 204: Wireless Ethernet Screen

- Touch the WIRELESS ETHERNET tab.
- To turn the WIFI on, touch the WIFI STATUS/ ON tab.
- To change the WIFI password—STRONGLY RECOMMENDED—touch the WIFI PWD-tab. Using the keyboard, enter a new password.
- Touch the Save button to close and return to the WIFI SETTINGS screen.
- To add the WIFI settings to the INFORMATION screen, touch the ALLOW WIFI CONTROL / ON tab. The INFORMATION screen will now display a WIFI tab (Figure 205).

NOTE:

This will allow WIFI to be turned on/off without a password.



Figure 205: Wireless Ethernet Screen

- Save settings.
- Turn on the Web enabled device.
- Find the wireless Ethernet network on the device with the SSID name.
- Type in the password (default is 121212) on the web enabled device.
- Open the browser and enter the IP address (default is 192.168.50.1) to go to the TotalAlert Infinity™ home page. This page displays active alarms, gas pressure signals, Network devices, device information, and the event log.

5.0 Retrofit

Retrofit Kits Include:

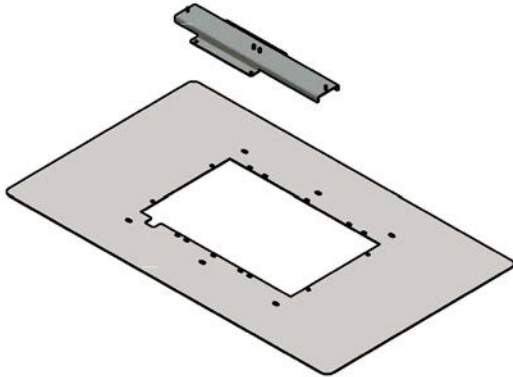

Figure 206: TA2/MEGA2/Others 8-Gas Trim Kit

4107 2206 15 Contents	
Qty	Description
1	Trim Plate Retrofit 16x27
1	Adapter Bracket, Power Supply 2-Position
4	Hardware #6-32 x 1/4" long Pan Head Machine screw

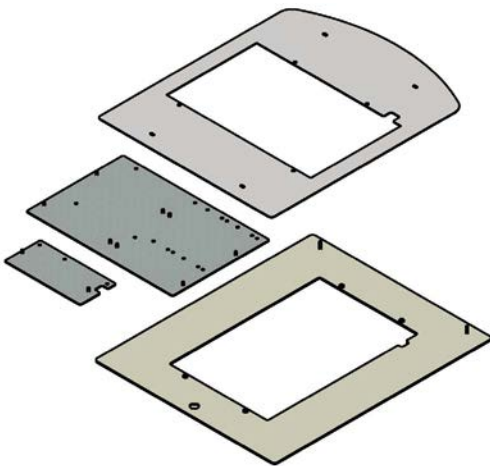

Figure 207: TotalAlert¹ Trim Kit

4107 2206 16 Contents	
Qty	Description
1	Trim Plate Retrofit TotalAlert ¹ Single
1	Trim Plate Retrofit TotalAlert ¹ Double
1	Adapter Bracket, Power Supply
1	Adapter Bracket, I/O Modules
4	Hardware #6-32 x 1/4" long Pan Head Machine screw

NOTE: Due to the nature of retrofit installations, you will have parts left over when finished.

5.1 Retrofit of TotalAlert2 Master Alarm Panel (32 points or 64 points)

NOTE: The existing power supply will be reused for the new alarm.

5.1.1 Remove Components from Existing Alarm

1. Open old alarm panel to be retrofitted and ensure that the retrofit kit to be installed is correct according to the number of Signal Inputs, Relay outputs, and/or Gas Sensor signals (See Appendix A).
2. Test Master alarm signals to validate wiring and document all signal wires coming into the box with alarm type and locations prior to disconnecting the front panel. This information will be required to setup the new alarm.
3. Turn off the supply power to the alarm.
4. Disconnect the power cable and the ribbon cables from the front panel and remove and discard the front panel.

CAUTION: Verify that power has been turned off prior to working on the alarm.

5.1.2 Install New Components

1. Install trim plate to rough-in box using 4 of the provided screws (Figures 208 & 209). Slots in the trim plate will align with existing holes in the rough-in box flanges.

NOTE: Trim ring portion can be removed from the trim plate if the surrounding wall area is in good condition. Mounting of the trim ring only to the rough-in box will result in a cleaner retrofit installation.

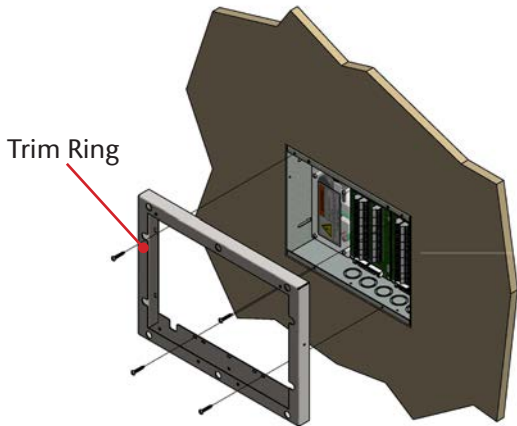

Figure 208: Retrofit Trim Ring Installation

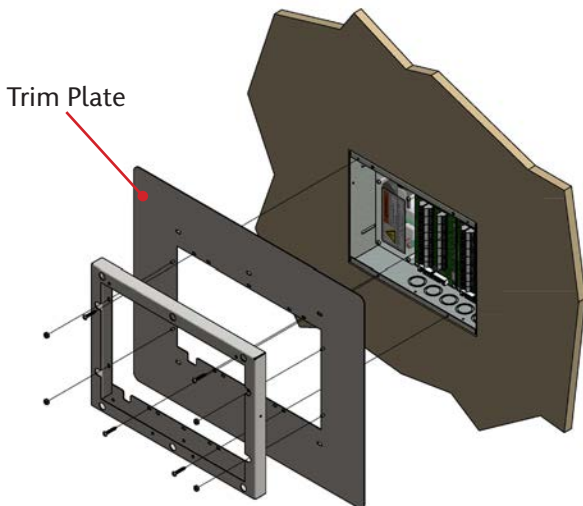

Figure 209: Trim Plate Assembly

2. Mount the Front Panel assembly to the trim ring using the countersink sheet metal screws provided on the trim ring (Figure 209).
3. Connect the lanyard to the threaded extension on the right side of the trim ring.
4. Connect the ground cable from the front panel to the rough-in box (Figure 210).

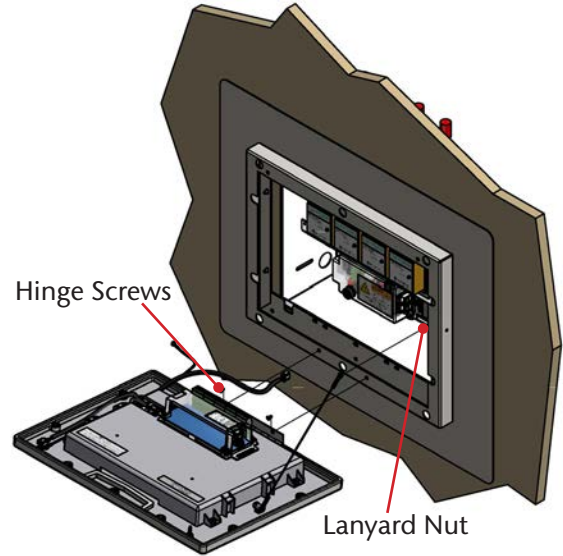

Figure 210: Front Panel Mounting

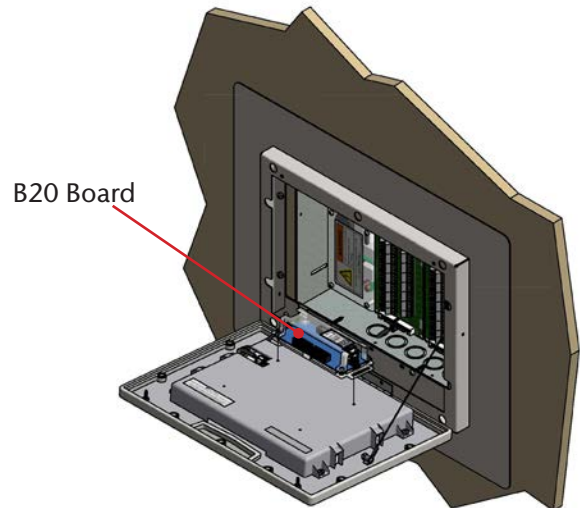

Figure 211: Front Panel Installation

5. Install B20 I/O module to the back of the Front Panel assembly using the screws provided on the cover (Figure 211).
6. Connect the grey cable on the Front panel to one of the white sockets on the B20 module.
7. Connect the power cable to opposite end of the B20 module.
8. Connect ribbon cables from breakout boards to the B20 module noting the “A” and “B” sides of the module match the “A” and “B” boards in the rough-in box.
9. Turn on the supply power to the alarm and wait for the alarm to boot up.
10. Setup the new alarm by referring to the Quick Setup guide.

5.2 Retrofit of TotalAlert² Area Alarm Panel (4-gas, 8-gas) and MEGA2 Alarms

NOTE: The existing Digital Gas Sensors will be reused for the new alarm.

5.2.1 Remove Components from Existing Alarm

1. Open old alarm panel to be retrofitted and ensure that the retrofit kit to be installed is correct according to the number of Signal Inputs, Relay outputs, and/or Gas Sensor signals (See Appendix A).
2. Ensure that you have the additional trim kit if retrofitting a TA2/MEGA2, 8-Gas alarm (4107220615).
3. Test Master alarm signals to validate wiring and document all signal wires coming into the box with alarm type and locations prior to disconnecting the front panel. This information will be required to setup the new alarm.
4. Turn off the supply power to the alarm.

CAUTION: Verify that power has been turned off prior to working on the alarm.

5. Remove and discard the front panel from the existing alarm.
6. Remove the old power supply

5.2.2 Install New Power Supply

Mega Master / Area 4 Gas

- a. Install the metal standoff bracket that is included with the retrofit kit onto the studs the power supply was removed from.
- b. Mount the new Power Supply (B05) to the bracket using the nuts provided (Figure 212).

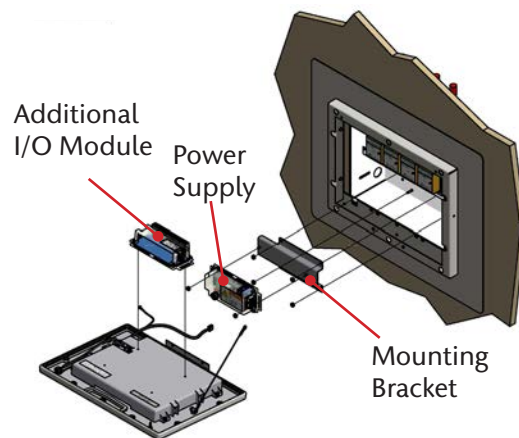

Figure 212: Power Supply, Module Mounting

TA2/Mega2 Area 8 Gas

- a. Install the 2 position metal standoff bracket that is included with the additional trim kit onto the studs the power supply was removed from (Figure 213).
- b. Mount the new Power Supply (B05) and the B60 gas input board to the bracket using the nuts provided with the modules.

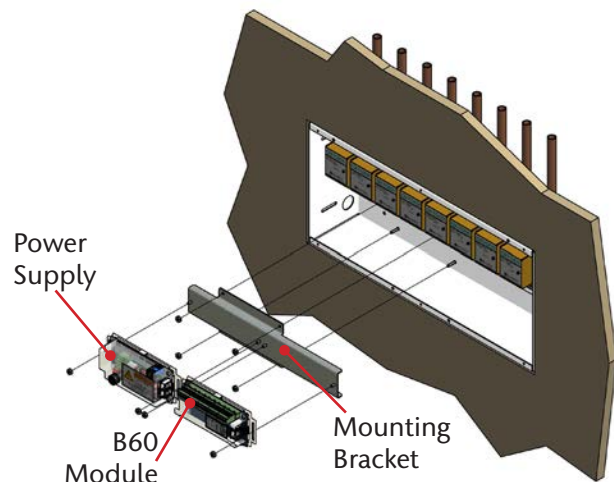

Figure 213: Power Supply, Module Mounting

TotalAlert Infinity™ NFPA Medical Gas Notification System

1. Locate the Ground cable attached to the power supply and connect the ring terminal end to the rough-in box for chassis ground. Use the self-drilling screw provided.
2. Remove the 4 corner screws from the power supply cover and remove the cover.
3. Connect the supply power Line and Neutral wires to the terminal block.
4. Connect the supply power Ground wire directly to the rough-in box.
5. Replace the power supply cover and screws.

5.2.3 Install New Components

1. Determine the best placement of the remaining I/O modules inside of the rough-in box.

NOTE: I/O Modules and Power Supply will need to be daisy chain connected via the grey cables supplied with each I/O module.

2. Mount the I/O Modules inside the rough-in box using the supplied hardware.
3. Connect the grey cable(s) provided; from the power supply to the white sockets on the I/O modules in a daisy chain manner (Figure 214).

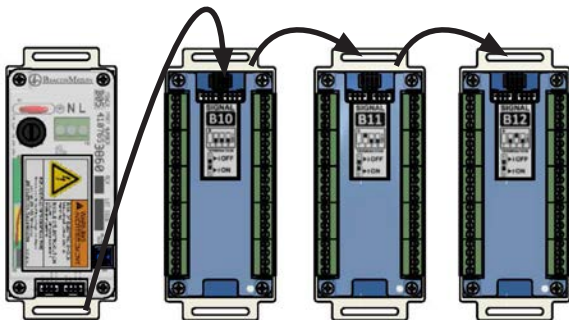

Figure 214: Daisy Chain of Power Supply

4. The last module in the chain needs to have the #1 DIP switch set to “ON” (Figure 215). Refer to the module ID label.

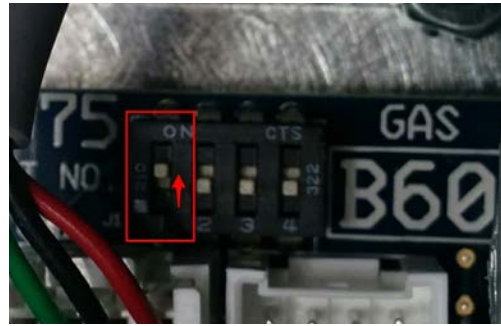

Figure 215: DIP Switch Setting

5. Connect all input signal / output signal / gas sensor wiring to their respective modules. Refer to the wiring diagram on the Quick Setup Guide for instructions.

5.2.4 Install Trim Plate

Mega Master / Area 4 Gas

- a. Install trim plate assembly to rough-in box using the provided screws and/or drywall anchors. Slots in the trim plate will align with existing holes in the rough-in box flanges.

NOTE: Trim ring portion can be removed from the trim plate if the surrounding wall area is in good condition. Mounting of the trim ring only to the rough-in box will result in a cleaner retrofit installation.

TA2/Mega2 Area 8 Gas

- a. Remove the trim ring from the standard trim plate and install the wide 27” wide x 16” tall trim plate from retrofit option kit (4107220615). Screws are provided in the option kit for attaching the trim ring to the trim plate (Figure 216).
- b. Install trim plate assembly to rough-in box using the provided screws and/or drywall anchors. Slots in the trim plate will align with existing holes in the rough-in box flanges.

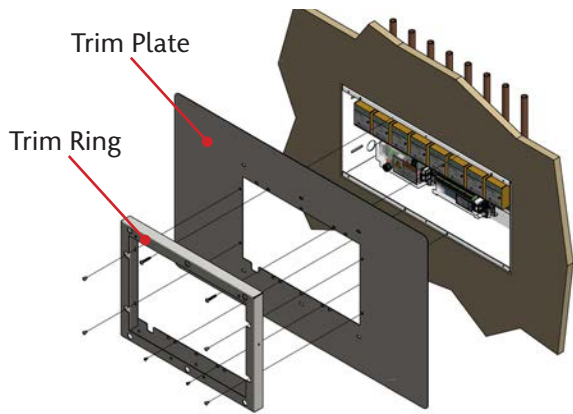

Figure 216: Retrofit Area Trim Panel

1. Mount the Front Panel assembly to the trim ring using the countersink sheet metal screws provided on the trim ring (Figure 216).
2. Connect the lanyard to the threaded extension on the right side of the trim ring.
3. Connect the grey cable from the Front Panel to the other white socket on the Power Supply board.
4. Connect the ground cable from the Front Panel to the rough-in box using the provided self-drilling screw.
5. Turn on the supply power to the alarm and wait for the alarm to boot up.
6. Setup the new alarm by referring to the Quick Setup guide.

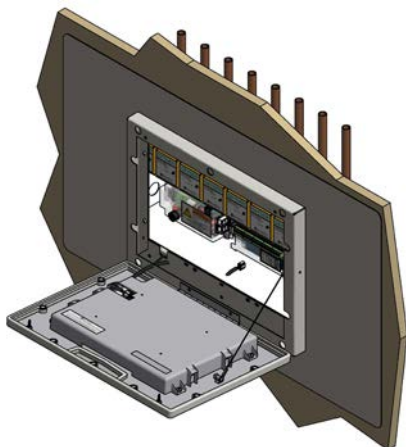

Figure 217: Front Panel Assembly Mounting

5.3 Retrofit of TotalAlert¹ Alarm Panels

5.3.1 Remove Components from Existing Alarm

1. Open old alarm panel to be retrofitted and ensure that the retrofit kit to be installed is correct according to the number of Signal Inputs, Relay outputs, and/or Gas Sensor signals (See Appendix A).
2. Ensure that you have the additional trim kit for retrofitting a TotalAlert1 Single or Double alarm panel (4107220616).
3. Test Master alarm signals to validate wiring and document all signal wires coming into the box with alarm type and locations prior to disconnecting the front panel. This information will be required to setup the new alarm.
4. Turn off the supply power to the alarm.

CAUTION: Verify that power has been turned off prior to working on the alarm.

5. Remove and discard the front panel from the existing alarm. For TotalAlert1 Double, remove the door from the hinges, remove the lock set and set aside, and discard the door.

NOTE: For TotalAlert1 alarms, all internal components will need to be removed and replaced with new components.

6. Remove and discard of all the components from the alarm rough-in box.
7. Ensure that no low voltage signal wiring is pulled through the input power knock-outs inside of the rough-in box.
8. Mount new power supply adapter bracket (small bracket included with kit 4107220616) reusing the hardware and location from the old power supply (Figure 218).

TotalAlert Infinity™ NFPA Medical Gas Notification System

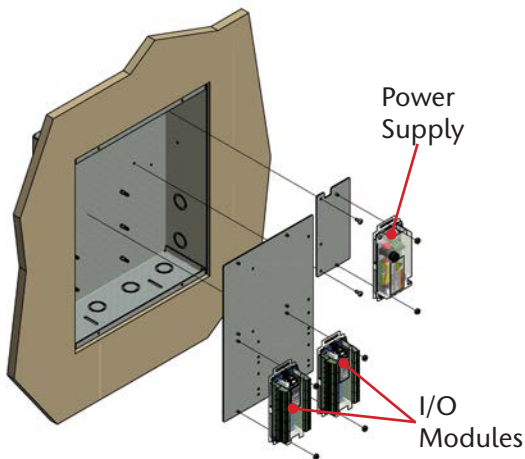

Figure 218: TotalAlert Infinity™ Adapter Bracket Mounting Single

9. Snap the I/O module adapter bracket (large bracket included with kit 4107220616) onto the standoffs at the rear of the rough-in box (Figure 219).

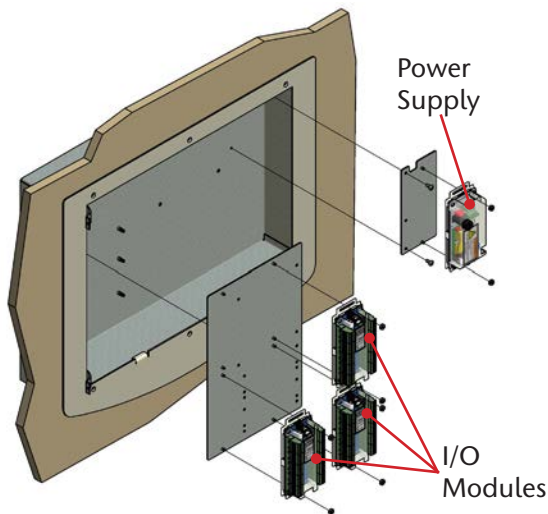

Figure 219: TotalAlert Infinity™ Double Adaptor Bracket Mounting

5.3.2 Install Gas-Specific Sensors (Area or Combination alarms only)

Local Sensors

1. Install the TotalAlert Infinity™ gas specific transducers following your records from the disassembly.

NOTE: If a DISS demand check valve is not in place then one will need to be installed to comply with NFPA 99.

CAUTION: Ensure that the pressure on the pipeline in the alarm area has been released before removing any components from the pipeline connection.

2. Remove any existing fittings or adapters from the gas tube in the rough-in box.
3. Install the gas specific DISS demand check valve from the supplied tubing package into the appropriate gas tube. To prevent gas leaks, wrap Teflon tape a minimum of three times around the fitting pipe threads.
4. Tighten the adapter until you feel resistance; then turn the fitting 2 full turns.

NOTE: If the gas transducer needs to be repositioned in the rough-in box or thread size / fitting style is not compatible; use the included fitting kits to adapt or relocate as needed. Fitting/adaptor kit needs to be installed upstream from the DISS connection at the gas sensor.

5. Install the gas specific transducer.
6. Tighten the DISS nut until you feel resistance.
7. Repeat steps 2-6 until all of the gas specific transducers are installed.
8. Verify that the gas specific transducers are in the appropriate places by referring to your records from the disassembly.
9. Return pressure to each gas sensor, one gas at a time and check for leaks. Make any adjustments or corrections as needed.

Remote Sensors

1. Sensors are packaged loose so they can easily be installed remotely.
2. Remote sensors are installed directly to the pipeline outside of the rough-in box. Pipeline connections are to be made to the top of the pipe.

NOTE: If a DISS demand check valve is not in place then one will need to be installed to comply with NFPA 99.

TotalAlert Infinity™ NFPA Medical Gas Notification System

CAUTION: Ensure that the pressure on the pipeline in the alarm area has been released before removing any components from the pipeline connection.

3. Remove any existing fittings or adapters from the gas tube.
4. Install the gas specific DISS demand check valve from the supplied tubing package into the appropriate tube. To prevent gas leaks, wrap Teflon tape a minimum of three times around the fitting pipe threads.
5. Tighten the adapter until you feel resistance; then turn the fitting 2 full turns.

NOTE: If the DISS demand check thread size is not compatible with the existing tubing connection; use the included fitting kits to adapt as needed. Fitting/adaptor kit needs to be installed upstream from the DISS connection at the gas sensor.

6. Install the gas specific transducer.
7. Tighten the DISS nut until you feel resistance.
8. Repeat steps 3-7 until all of the gas specific transducers are installed.
9. Verify that the gas specific transducers are in the appropriate places by referring to your records from the disassembly.
10. Return pressure to each gas sensor, one gas at a time and check for leaks. Make any adjustments or corrections as needed.

NOTE: Remote sensors can also be installed in compatible BeaconMedæx Zone Valve boxes with additional adapter kit (4107401625). One required for each sensor.

5.3.3 Install New Power Supply

1. Mount the new Power Supply (B05) to the adapter bracket using the nuts provided (Figures 218 - 221).
2. Locate the Ground cable attached to the power supply and connect the ring terminal end to the rough-in box for chassis ground. Use the self-drilling screw provided.
3. Remove the 4 corner screws from the Power Supply cover and remove the cover.
4. Connect the supply power Line and Neutral wires to the terminal block.
5. Connect the supply power Ground wire to the rough-in box.
6. Replace the power supply cover and screws.

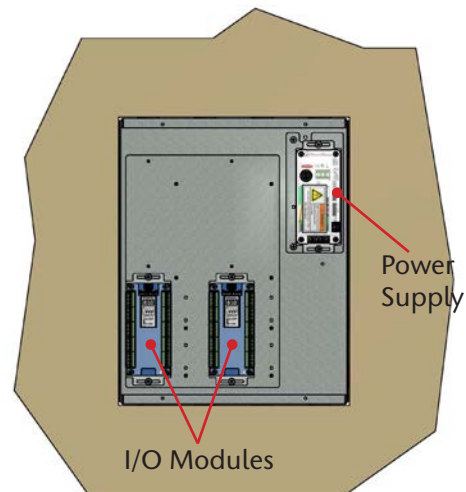

Figure 220: TotalAlert Infinity™ Single Module Positions

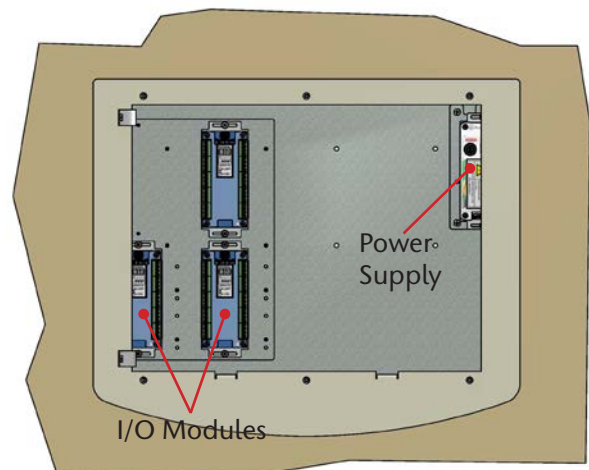

Figure 221: Double Module Positions

5.3.4 Install New Components

1. Mount the I/O Modules to the large adapter bracket using the nuts provided.

NOTE: I/O Modules and Power Supply will need to be daisy chain connected via the grey cables supplied with each I/O module (See figure 214).

2. Connect the grey cable(s) provided; from the power supply to the white sockets on the I/O modules in a daisy chain manner.
3. The last module in the chain needs to have the #1 DIP switch set to “ON” (See Figure 215). Refer to the module ID label.
4. If alarm is an Area or Combination with local sensors, consider the position and placement of the pressure transducers before drilling or mounting any components. Use the sensor adapter kits provided to relocate the sensors if required.
5. Connect all input signal / output signal / gas sensor wiring to their respective modules. Refer to the wiring diagram on the Quick Setup Guide for instructions.

5.3.5 Install Trim Plate

1. Remove the trim ring from the standard trim plate and install the corresponding trim plate from retrofit option kit (4107220616) (Figures 222 & 223). Screws are provided in the option kit for attaching the trim ring to the trim plate. TotalAlert¹ Double also requires switching over the door lock set to the new trim plate.
2. Install trim plate assembly to the rough-in box using the holes that align to the rough-in box flanges (TotalAlert¹ Single), or attach trim plate assembly to the existing hinges (TotalAlert¹ Double).

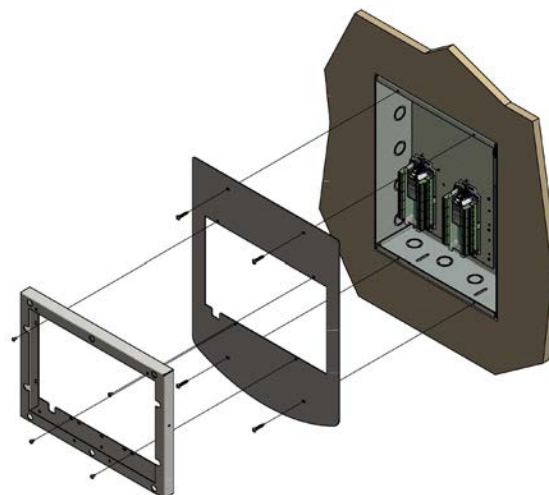

Figure 222: TotalAlert Infinity™ Single Trim Plate Installation

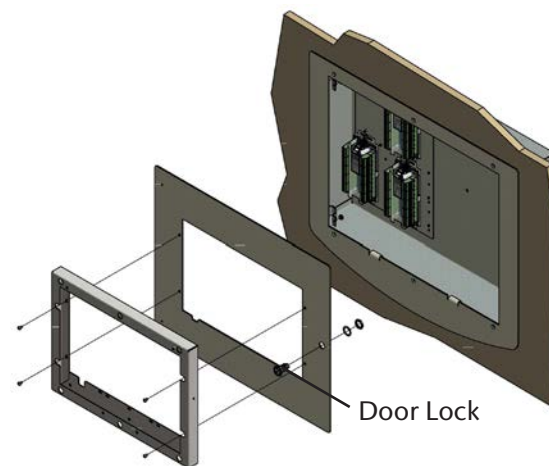

Figure 223: TotalAlert Infinity™ Double Trim Plate Installation

3. Mount the Front Panel assembly hinge to the trim ring using the countersink sheet metal screws provided on the trim ring (Figures 224 - 226).
4. Connect the lanyard to the threaded extension on the right side of the trim ring.
5. Connect the grey cable from the Front Panel to the white socket on the Power Supply board.
6. Connect the Ground cable from the Front Panel to the rough-in box.
7. Turn on the supply power to the alarm and wait for the alarm to boot up.
8. Setup the new alarm by referring to the Quick Setup guide.

TotalAlert Infinity™ NFPA Medical Gas Notification System

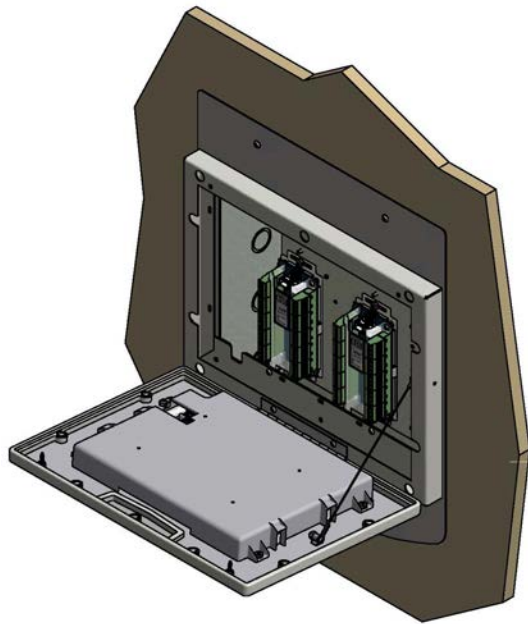

Figure 224: TotalAlert Infinity™ Single Mount Front Panel Assembly

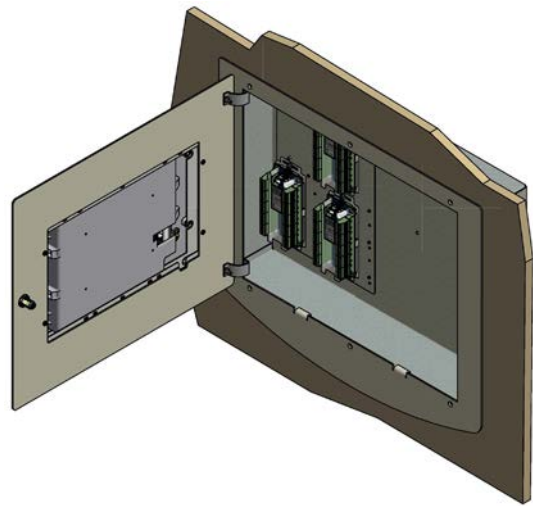

Figure 226: TotalAlert Infinity™ Double Mount Front Panel Assembly

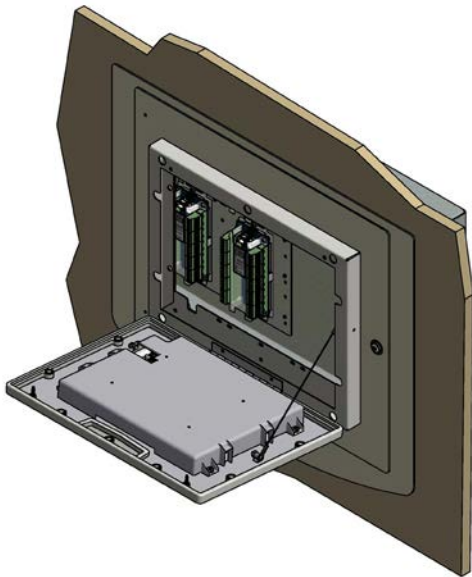

Figure 225: TotalAlert Infinity™ Double Mount Front Panel Assembly

5.4 Retrofit of Other Alarm Panels

5.4.1 Remove Components from Existing Alarm

1. Open old alarm panel to be retrofitted and ensure that the retrofit kit to be installed is correct according to the number of Signal Inputs, Relay outputs, and/or gas sensor signals (See Appendix A).
2. If alarm to be retrofit has a rough-in box greater than 20 inches wide, you will need the optional trim kit (4107220615) to cover the existing box.
3. Test Master alarm signals to validate wiring and document all signal wires coming into the box with alarm type and locations prior to disconnecting the front panel. This information will be required to setup the new alarm.
4. Turn off the supply power to the alarm.

CAUTION: Verify that power has been turned off prior to working on the alarm.

5. Remove and discard the front panel from the existing alarm.
6. Remove and discard of all the components from the alarm rough-in box.
7. Ensure that no low voltage signal wiring is pulled through the input power knockouts inside of the rough-in box.
8. Remove any studs and screws flush with the rough-in box.
9. Remove all sharp edges and burrs from open knockouts and from the inside of the rough-in box.
10. Remove all existing regulatory compliance labels from the inside of the rough-in box.
11. Clean the inside of the rough-in box to remove all of the metal shavings and dirt.

5.4.2 Determine Proper Placement of New Components

1. Determine the proper placement of the TotalAlert Infinity™ Retrofit Alarm components inside of the rough-in box. Refer to Appendix A and illustrations for recommended placement.

NOTE: I/O Modules and Power Supply will need to be daisy chain connected via the grey cables supplied with each I/O module (See Figure 215) The last module in the chain needs to have the #1 DIP switch set to “ON” (See Figure 215).

2. If alarm is an Area or Combination with local sensors, consider the position and placement of the pressure transducers before drilling or mounting any components. Use the sensor adapter kits provided to relocate the sensors if required.

5.4.3 Install Gas-Specific Sensors (Area or Combination alarms only)

Local Sensors

1. Install the TotalAlert Infinity™ gas specific transducers following your records from the disassembly.

NOTE: If a DISS demand check valve is not in place then one will need to be installed to comply with NFPA 99.

CAUTION: Ensure that the pressure on the pipeline in the alarm area has been released before removing any components from the pipeline connection.

2. Remove any existing fittings or adapters from the gas tube in the rough-in box.
3. Install the gas specific DISS demand check valve from the supplied tubing package into the appropriate gas tube. To prevent gas leaks, wrap Teflon tape a minimum of three times around the fitting pipe threads.
4. Tighten the adapter until you feel resistance; then turn the fitting 2 full turns.

TotalAlert Infinity™ NFPA Medical Gas Notification System

NOTE: If the gas transducer needs to be repositioned in the rough-in box or thread size / fitting style is not compatible; use the included fitting kits to adapt or relocate as needed. Fitting/adaptor kit needs to be installed upstream from the DISS connection at the gas sensor.

5. Install the gas specific transducer.
6. Tighten the DISS nut until you feel resistance.
7. Repeat steps 2-6 until all of the gas specific transducers are installed.
8. Verify that the gas specific transducers are in the appropriate places by referring to your records from the disassembly.
9. Return pressure to each gas sensor, one gas at a time and check for leaks. Make any adjustments or corrections as needed.

Remote Sensors

1. Sensors are packaged loose so they can easily be installed remotely.
2. Remote sensors are installed directly to the pipeline outside of the rough-in box. Pipeline connections are to be made to the top of the pipe.

NOTE: If a DISS demand check valve is not in place then one will need to be installed to comply with NFPA 99.

CAUTION: Ensure that the pressure on the pipeline in the alarm area has been released before removing any components from the pipeline connection.

3. Remove any existing fittings or adapters from the gas tube.
4. Install the gas specific DISS demand check valve from the supplied tubing package into the appropriate tube. To prevent gas leaks, wrap Teflon tape a minimum of three times around the fitting pipe threads.
5. Tighten the adapter until you feel resistance; then turn the fitting 2 full turns.

NOTE: If the DISS demand check thread size is not compatible with the existing tubing connection; use the included fitting kits to adapt as needed. Fitting/adaptor kit needs to be installed upstream from the DISS connection at the gas sensor.

6. Install the gas specific transducer.
7. Tighten the DISS nut until you feel resistance.
8. Repeat steps 3-7 until all of the gas specific transducers are installed.
9. Verify that the gas specific transducers are in the appropriate places by referring to your records from the disassembly.
10. Return pressure to each gas sensor, one gas at a time and check for leaks. Make any adjustments or corrections as needed.

NOTE: Remote sensors can also be installed in compatible BeaconMedæx Zone Valve boxes with additional adapter kit (4107401625). One required for each sensor.

5.4.4 Install Power Supply

NOTE: Alarm panels require 100 to 250 VAC 50/60Hz power. Refer to wiring schematics located on the quick setup guide included. For NFPA 99 compliance, alarm panel must be connected to the life safety branch of the emergency electrical system.

1. Position the power supply module in the rough-in box to verify the fit prior to installation.
2. Mount the power supply using the provided nuts or self-drilling screws
3. Locate the Ground cable attached to the power supply and connect the ring terminal end to the rough-in box using the provided self-drilling screw.
4. Remove the 4 corner screws from the power supply cover and remove the cover.
5. Connect the supply power Line and Neutral wires to the terminal block.
6. Connect the supply power Ground wire to the rough-in box.
7. Replace the power supply cover and screws.

5.4.5 Install I/O Modules

1. Position the Input/Output modules in the rough-in box to verify the fit prior to installation.
2. Mount each I/O module using the provided nuts or self-drilling screws.
3. Connect the grey cable(s) provided; from the Power Supply to the white sockets on the I/O modules in a daisy chain manner (See Figure 214).
4. The last module in the chain needs to have the #1 DIP switch set to "ON" (See Figure 215). Refer to the module ID label.
5. Connect all input signal / output signal / gas sensor wiring to their respective modules. Refer to the wiring diagram on the Quick Setup Guide for instructions.

5.4.6 Install Trim Components

The standard retrofit alarm kit comes with a 20" x 16" trim plate assembly which will work for most of the typical installations (Figure 227). In some cases the trim plate is not needed and the existing rough-in box / wall opening can be covered by using the trim ring alone; in that case, remove the 20" x 16" trim plate prior to installing the trim ring to the wall/rough-in box.

For retrofitting of larger 8-gas rough-in panels (up to 24" wide), an optional trim plate kit is required (4107220615) to cover the larger wall opening (Figure 228). If this is required, remove the 20" x 16" trim plate from the trim ring and install the 27" x 16" trim plate prior to installing the trim assembly to the wall/rough-in box. *Note the orientation of the square notches on the trim ring and plate.

1. Position the trim plate over the rough-in box and determine the best mounting method for your case. Use a level to check that the trim plate is plumb.
2. Mark the mounting locations on the dry-wall using the trim plate as your guide.
3. Install the drywall anchors provided as needed.
4. Reposition the trim plate and install the screws provided into the anchors and/or directly into the rough-in box.

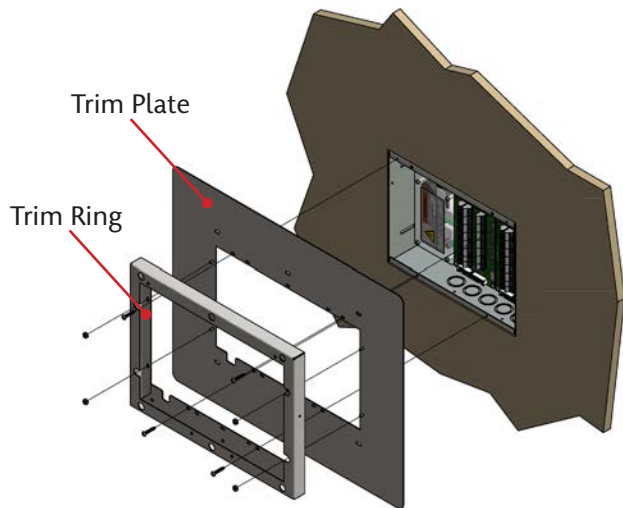

Figure 227: Standard Trim Plate Assembly

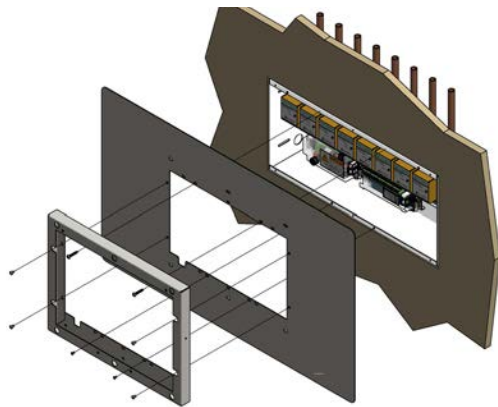

Figure 228: Optional Retrofit Area Trim Panel

5.4.7 Install Front Panel

1. Mount the Front Panel assembly to the trim ring using the countersink sheet metal screws provided on the trim ring.
2. Connect the lanyard to the threaded extension on the right side of the trim ring (Figure 229).
3. Connect the grey cable from the Front Panel to the white socket on the Power Supply board.
4. Connect the Ground cable on the Front panel to the rough-in box using the provided self-drilling screw.
5. Turn on the supply power to the alarm and wait for the alarm to boot up.
6. Setup the new alarm by referring to the Quick Setup guide.

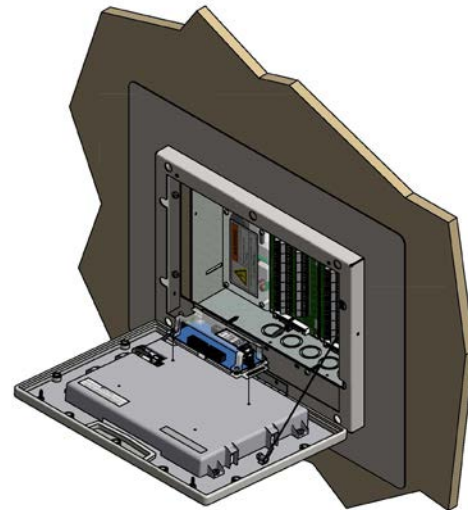

Figure 229: Front Panel Installation

TotalAlert Infinity™ NFPA Medical Gas Notification System

Appendix A:

Variable A Alarm Type and Size	
Allowable Value	Description
B00	Blank
A10	Area Alarm, Up to 8 Area Gases
M01	Master, 0 Inputs, 16 Relay Outputs
M10	Master, 20 Inputs
M11	Master, 20 Inputs, 16 Relay Outputs
M12	Master, 20 Inputs, 32 Relay Outputs
M13	Master, 20 Inputs, 48 Relay Outputs
M20	Master, 40 Inputs
M21	Master, 40 Inputs, 16 Relay Outputs
M22	Master, 40 Inputs, 32 Relay Outputs
M30	Master, 60 Inputs, 0 Relay Outputs
M31	Master, 60 Inputs, 16 Relay Outputs
M40	Master, 64 Inputs
C01	Combination, 10 Inputs, 6 Relay Outputs, Up to 3 Area Gases
C10	Combination, 20 Inputs, Display up to 6 Area Gases
C11	Combination, 20 Inputs, 16 Relay Outputs, Display up to 6 Area Gases
C12	Combination, 20 Inputs, 32 Relay Outputs, Display up to 6 Area Gases
C20	Combination, 40 Inputs, Display up to 6 Area Gases
C21	Combination, 40 Inputs, 16 Relay Outputs, Display up to 6 Area Gases
C30	Combination, 60 Inputs, Display up to 6 Area Gases
C40	Combination, 7 Inputs, 6 Relay Outputs, 4 Inputs for 4-20mA devices
C41	Combination, 27 Inputs, 6 Relay Outputs, 4 Inputs for 4-20mA devices
C42	Combination, 47 Inputs, 6 Relay Outputs, 4 Inputs for 4-20mA devices
C43	Combination, 67 Inputs, 6 Relay Outputs, 4 Inputs for 4-20mA devices
C44	Combination, 7 Inputs, 6 Relay Outputs, 4 Inputs for 4-20mA devices, Up to 6 Area Gases (maximum display of 6 gas badges, in combination of 4-20mA and gas sensors)

Notes:

* Limitations on Combination Panels:

- C10, C11, C12 Combinations
 - » 0-10 source signal Inputs used, Display up to 6 Area gases
 - » 11-20 source signal Inputs used, Display up to 4 Area gases
- C41
 - » 0-20 source signal Inputs used, Display up to 4 4-20mA devices
 - » 21-27 source signal Inputs used, Display up to 2 4-20mA devices
- C44
 - » Display up to 6 gas badges maximum, combination of 4-20mA and area gases, with maximum 4 4-20mA badges.

Retrofit Alarm Models



NOTE: For Area Alarm panels, sensor assemblies are not specific to "Remote" or "Local" installations. It is not necessary to designate the installation type in the model numbering.

Variable B Gas Type (Area and Combination Only)	
Allowable Value	Description
O	Oxygen
X	Nitrous Oxide
A	Medical Air
V	Medical Vacuum
W	WAGD
N	Nitrogen
C	Carbon Dioxide (CO2)
D	Oxygen 100 psig
F	Medical Air 100 psig
G	Carbon Dioxide 100 psig
9	Instrument Air
1	CO2-O2 (CO2 over 7%)
2	O2-CO2 (CO2 not over 7%)
3	HE-O2 (HE over 80%)
4	O2-HE (HE not over 80%)
7	Laboratory Air
8	Laboratory Vacuum
H	Helium
J	Argon
S	Surgical Air
B	AGSS
E	N2O-O2
M	Mixed Gas

Example: TotalAlert Infinity™ Master Alarm Retrofit with 40 Inputs and 32 Relay Outputs

Example Model Number: T3-M22-R

Example: TotalAlert Infinity™ Retrofit AREA Alarm with 4 gases - Oxygen, Nitrous Oxide, Medical Air, and Vacuum

Example Model Number: T3-A10-OXAV-R

Example: TotalAlert Infinity™ Combination Retrofit Alarm with 10 Inputs, 6 Relay Outputs, and 3 gases - Oxygen, Medical Air, and Medical Vacuum

Example Model Number: T3-C01-OAV-R

TotalAlert Infinity™ NFPA Medical Gas Notification System

Typical Retrofit Layouts (Recommended Installation)

Module Components	
Letter Designator	Description
A	B05 Power Supply
B	B10-B12 Module (Signals, 20 Inputs)
C	B20 Module (TotalAlert2 Retrofit only, 64 Inputs)
D	B40-B43 Module (16 Relay Out)
E	B50 Module (4-20mA, 4 devices, 7 inputs, 6 outputs)
F	B60 Module (Gas Input, 8 gases, 1 output)
G	B65 Module (Combination, 3 gases, 10 inputs, 6 outputs)

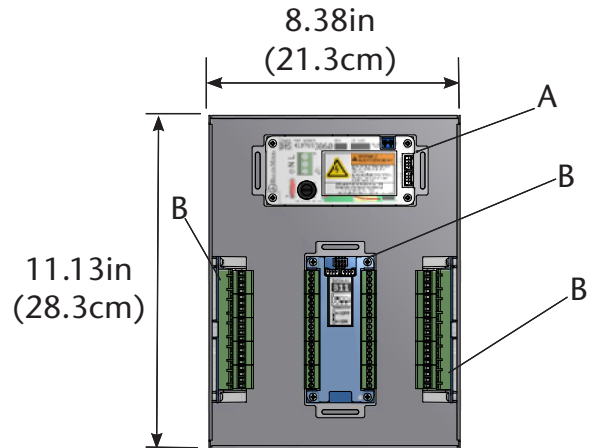

Multi-Signal Alarm from Medaes, Ohmeda, or Ohio

Dimensions

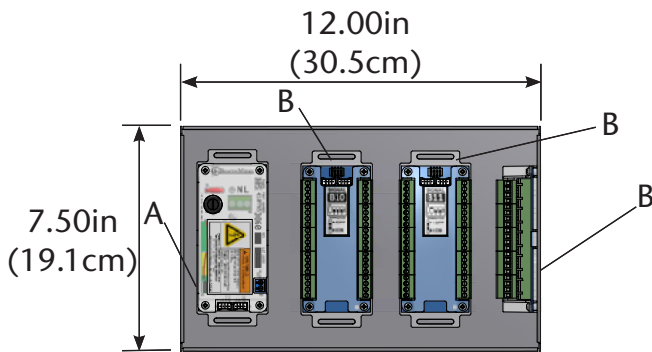

Digital I and II Alarm from Chemetron

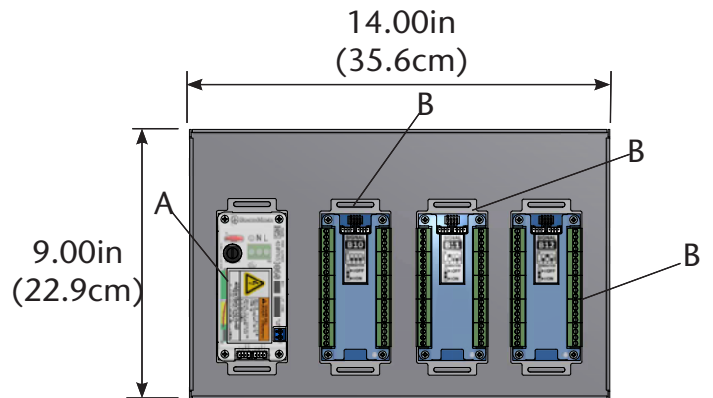

MedPlus Medical Gas Alarm from Hill-Rom or Medaes or Alert1 and 2 Series Alarm from Amico

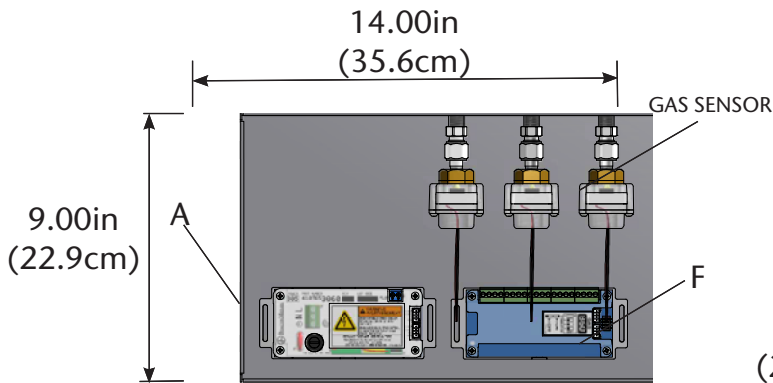

MedPlus Medical Gas Alarm ^{you-5} from Hill-Rom or Medaes or Alert1 and 2 Series Alarm from Amico

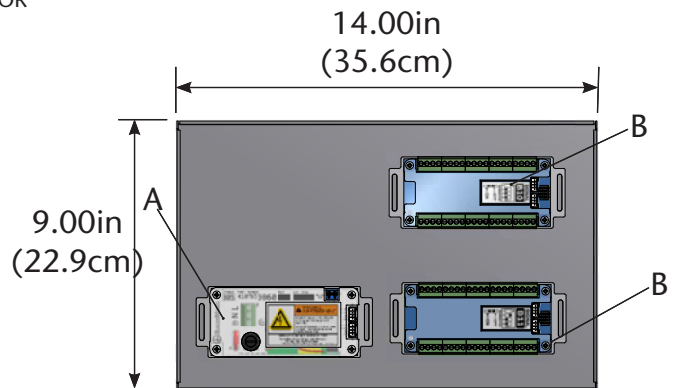

MedPlus Medical Gas Alarm from Hill-Rom or Medaes or Alert1 and 2 Series Alarm from Amico

TotalAlert Infinity™ NFA Medical Gas Notification System

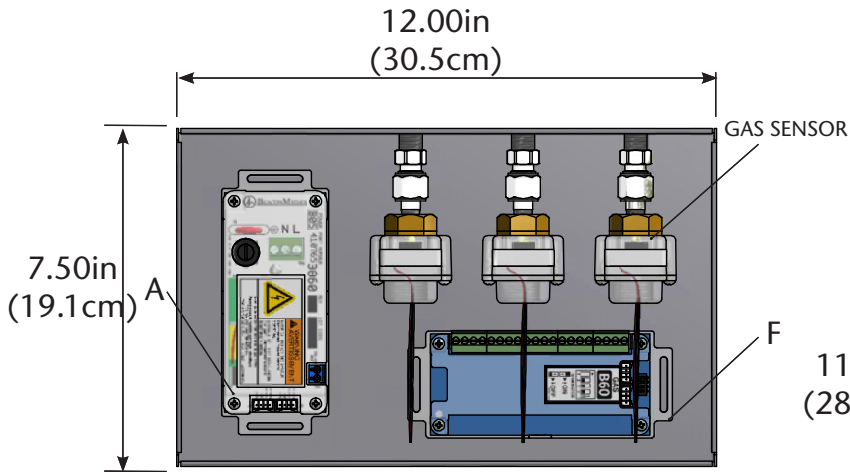

Digital I and II Alarm from Chemetron

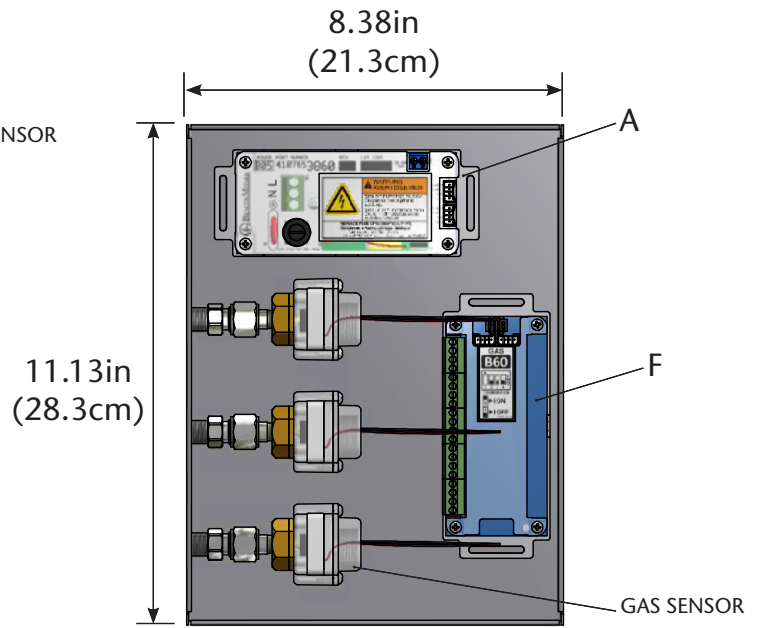

Line Pressure Alarms from Medaes, Ohmeda, or Ohio

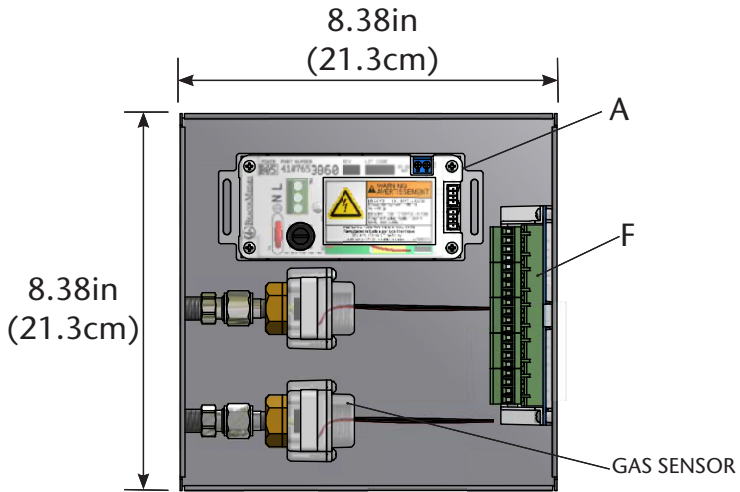

Line Pressure Alarms from Medaes, Ohmeda, or Ohio

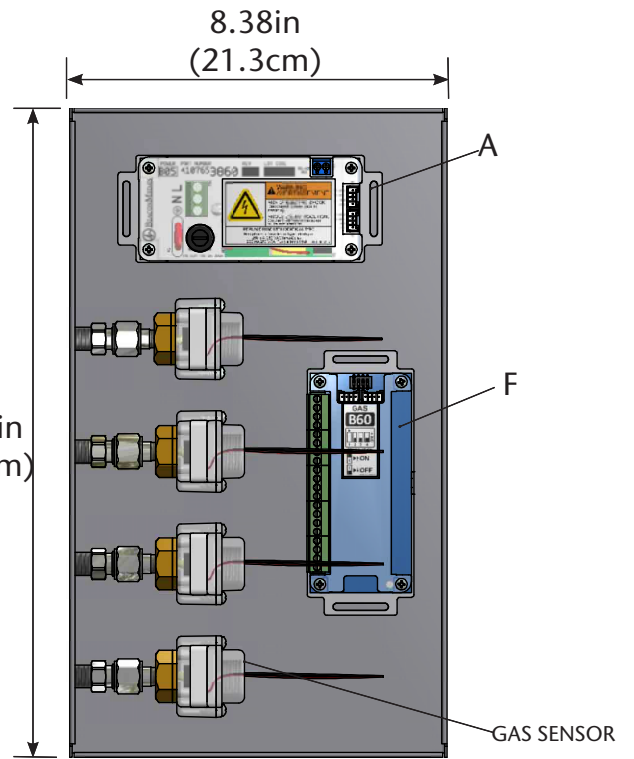

Line Pressure Alarms from BeaconMedaes, Medaes, Ohmeda, or Ohio

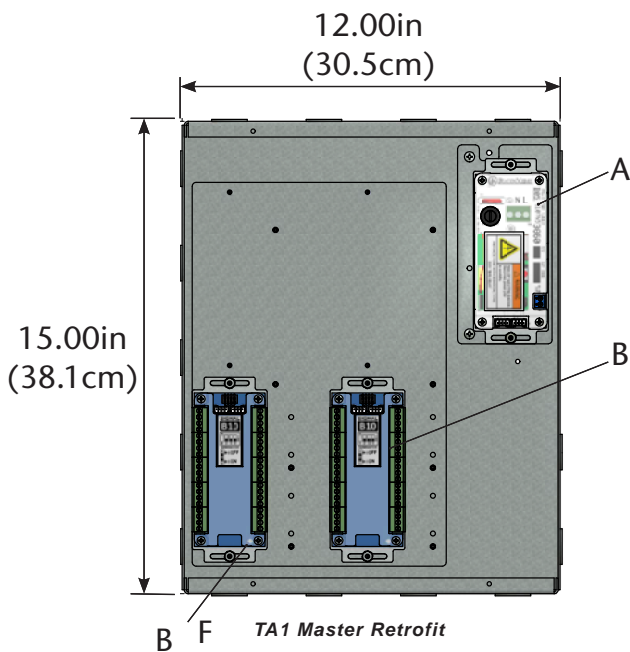

TotalAlert Infinity™ NFPA Medical Gas Notification System

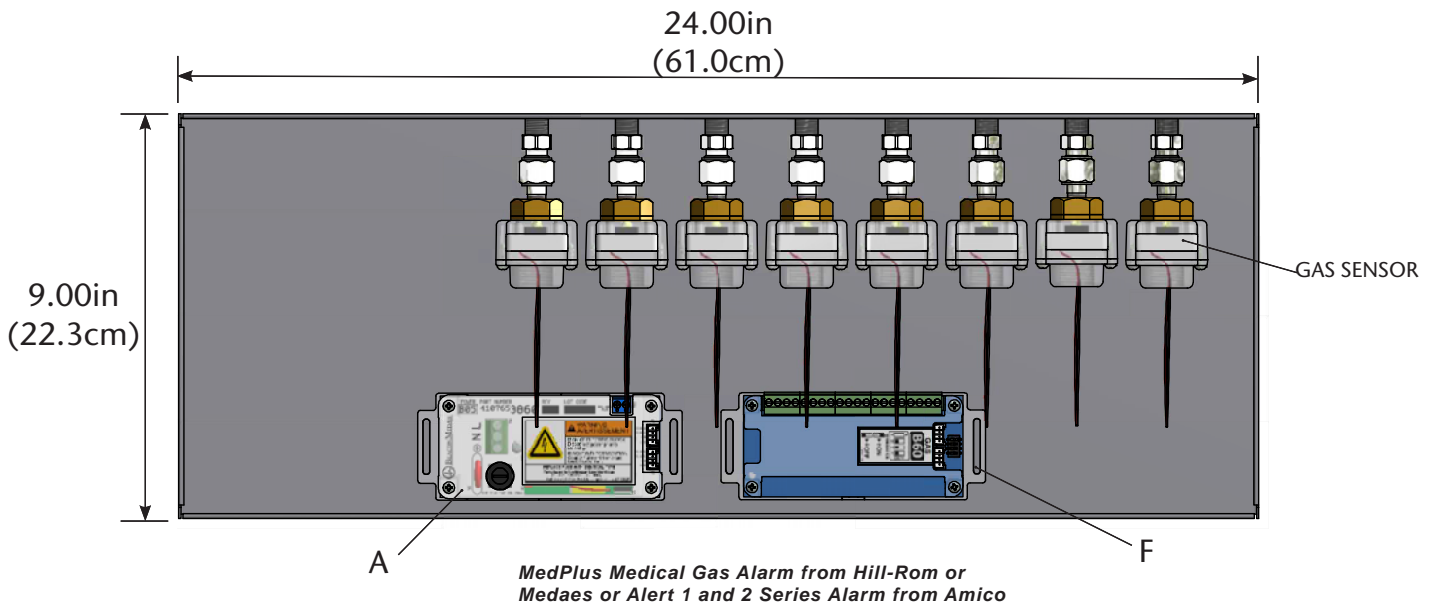
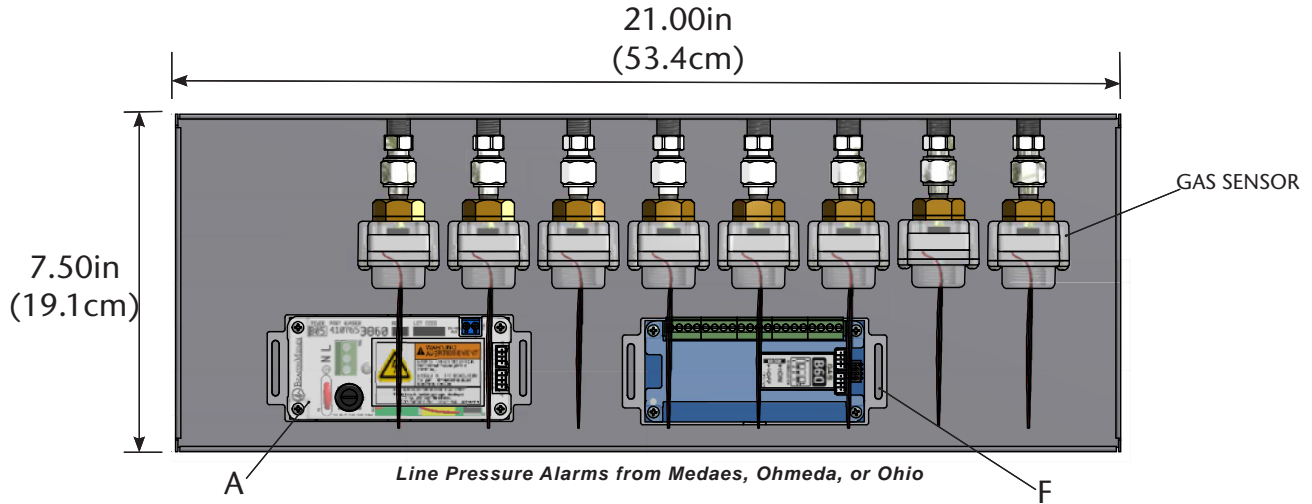
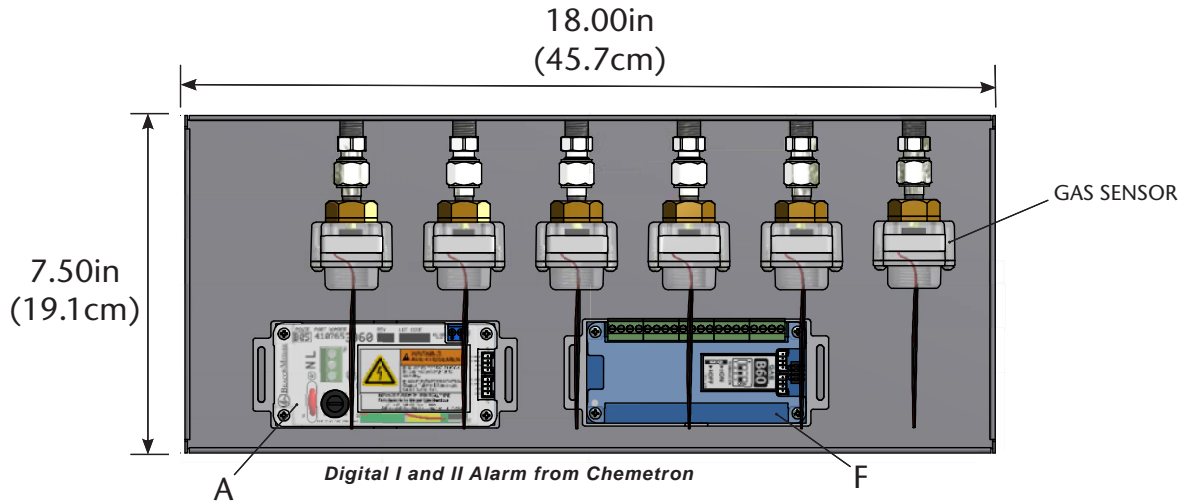

6.0 Maintenance

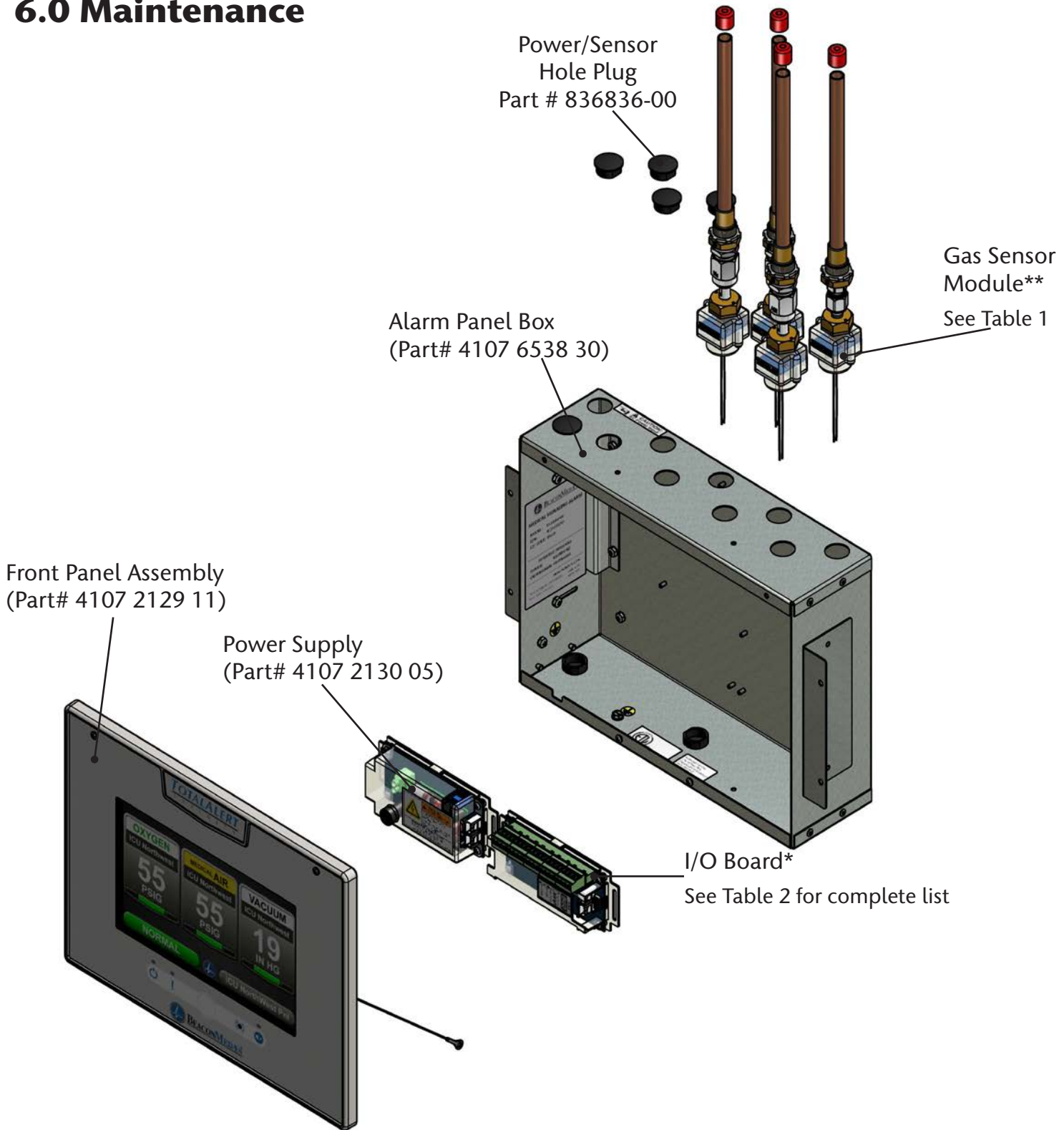

Figure 230: Maintenance

TotalAlert Infinity™ NFPA Medical Gas Notification System

***Table 1: Gas Sensor Module Options
(Service replacement only)**

Part Number	Gas Sensor Assembly
4107 4016 54	O2 Sensor Assembly
4107 4016 55	N2O Sensor Assembly
4107 4016 56	MedAir Sensor Assembly
4107 4016 57	Vac Sensor Assembly
4107 4016 58	N2 Sensor Assembly
4107 4016 59	IAIR Sensor Assembly
4107 4016 60	WAGD Sensor Assembly
4107 4016 61	CO2 Sensor Assembly
4107 4016 62	CO2-O2 Sensor Assembly
4107 4016 63	O2-CO2 Sensor Assembly
4107 4016 64	HE-O2 Sensor Assembly
4107 4016 65	O2-HE Sensor Assembly
4107 4016 66	HE Sensor Assembly
4107 4016 67	LAB-AIR Sensor Assembly
4107 4016 68	LAB-VAC Sensor Assembly
4107 4016 69	O2-100 Sensor Assembly
4107 4016 70	MedAir-100 Sensor Assembly
4107 4016 71	CO2-100 Sensor Assembly
4107 4016 72	AR Sensor Assembly
4107 4016 73	AGSS Sensor Assembly
4107 4016 74	O2-N2O Sensor Assembly

Cleaning:

Use clean dry microfiber cloth or soft lint-free cloth to remove any smudges located on the touchscreen. Make sure not to apply too much pressure on the screen when cleaning it. Never use paper towels or tissue paper which contain wood fibers that will scratch any plastic surface.

****Table 2: I/O Boards
(Service replacement only)**

Part Number	I/O Boards	Description
4107 4016 36	B03 Advance Module	Advanced features board
4107 4016 37	B05 Power Module	Power supply
4107 4016 38	B1X (Signal Input Board)	20 Inputs
4107 4016 39	B20 (TA2 Signal Input Board)	64 Inputs from TA2
4107 4016 41	B4X (Relay Board)	16 Relay Outputs
4107 4016 42	B50 (4-20mA Combination Board)	4 Inputs for 4-20mA Signals
4107 4016 43	B60 (Gas Input Board)	8 Gases
4107 4016 44	B65 (Gas Combination Board)	3 Gases, 7 Inputs, 6 Relay Outputs

Periodic Maintenance:

Inspect the alarm periodically and perform a self test (see Section 4.1.7 - Information Screen). This ensures proper operation of the alarm. Any damaged components inside the alarm should be replaced by an authorized BeaconMedæx service technician.

For TotalAlert Infinity™ alarms, the coin cell battery on the Advanced Module needs to be replaced every 5 years. Replace with CR-2032 coin cell battery.

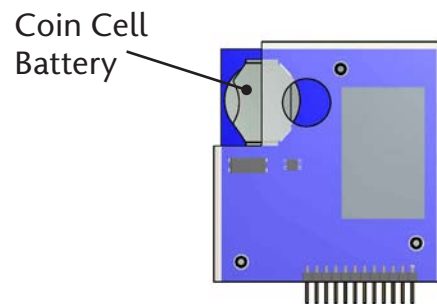

B03

Figure 231: Coin Cell Battery Maintenance

7.0 Troubleshooting

Symptom	Possible Cause	Corrective Action
No LED power indicator illuminated on alarm front panel	AC power is not turned on	Check AC power source.
	Blown power supply fuse	Replace fuse.
	AC power wiring is not connected	Check AC entrance wiring at power supply terminals.
	Power supply DC wire harness is not connected properly between the power supply and the main board	Check connections on each end including orientation of cable connectors. Reconnect if necessary.
	Faulty power supply assembly	Replace power supply
No green “heartbeat” power indicator is illuminated on connected boards	Board has not been initialized	Initialize board per instructions in manual.
	Board dip switches are not set correctly.	Set dip switches per diagram on board label.
	Cable not connected correctly	Check cable connections between boards.
No green “heartbeat” power indicator is illuminated on gas sensor	Sensor not connected to the Gas Input Board.	Verify correct sensor connection to Gas Input Board.
	Gas Input Board does not have power (no “heartbeat”)	Verify that Gas Input Board has been initialized and that dip switches are set correctly. See item 2 above.
Fast green "heartbeat" power indicator is illuminated on gas sensor (2 beats per second)	Sensor is reading out of range	Verify gas pressure in pipeline. If normal, replace sensor.
Red LED illuminated above warning indicator (!).	Active warning	Navigate to the warning screen by pressing the Information button, then selecting Warnings.
Lost Connection Warning	Alarm has lost network communication with manually enrolled device	Correct communication problem with networked device or remove the enrolled device from the Enrolled Devices list.
	The alarm has lost connection to a connected/ initialized board.	Check connections and cable to board.
Input active and Unassigned Warning	Master signal input is wired, but not assigned/programmed to an alarm signal	Assign the wired input to a valid alarm signal.
Sensor active and Unassigned Warning	Sensor is wired to the sensor input board, but not assigned/programmed	Assign the wired gas sensor to a valid gas input.
F1 displayed on Area badge	Gas sensor is not connected or has shorted.	Check gas sensor connection. If connection is good, replace sensor.
F2 displayed on Area badge	Gas sensor is reading below range (fault low).	Verify gas sensor connections and pipeline pressure. If connection and pressure are good, replace sensor.
F3 displayed on Area Badge	Gas sensor is reading above range (fault high).	Verify gas sensor connections and pipeline pressure. If connection and pressure are good, replace sensor.
F4 displayed on Area Badge	Gas sensor connected is wrong type of gas.	Connect the correct type gas sensor.

Troubleshooting (continued)

Symptom	Possible Cause	Corrective Action
Area Display pressure/ vacuum reading not matching pipeline.	Bad gauge on pipeline	Verify gauge used on pipeline
	Incorrect unit of measure	Check unit of measure, if incorrect, reprogram unit of measure.
	Gas sensor out of calibration	Adjust Zero Offset to correct reading. (Note: there is a max of 3 psi / 3 "hg offset adjustment). If sensor cannot be adjusted enough, replace sensor.
High or Low alarm, with normal pressure displaying on Area display	Alarm set points have been changed.	Verify / correct alarm set points.
Screen is blank, power on LED is illuminated	Screen backlight will time out and shut off. Motion sensor will awaken screen when motion is sensed within 5 ft of screen.	If screen does not awaken when approaching alarm, touch screen to awaken. Possible bad motion sensor.
Audible alarm reactivates a short period of time after Silence button has been pressed	A new alarm condition has occurred.	If alarm condition previously silenced, self corrects and then reactivates again, the alarm panel treats this as a new alarm condition.

8.0 Master Alarm Signal Input Data

Module	Board Input	Alarm Message	Source Location
B1_	X01		
	X02		
	X03		
	X04		
	X05		
	X06		
	X07		
	X08		
	X09		
	X10		
	X11		
	X12		
	X13		
	X14		
	X15		
	X16		
	X17		
	X18		
	X19		
	X20		

Blank Page



1800 Overview Drive Rock Hill, SC 29730
(888) 4-MEDGAS (888) 463-3427
Fax (803) 817-5750
www.beaconmedaes.com