

This drawing and the information contained thereon remain the property of BeaconMedæS and may not be used for other than the purpose for which it is loaned without the expressed written permission from BeaconMedæS Engineering.

Notes:

1. MATERIAL: POLYCARBONATE/ ABS BLEND WITH FLAME RETARDANT.  
COLOR: GREY PMS 427.

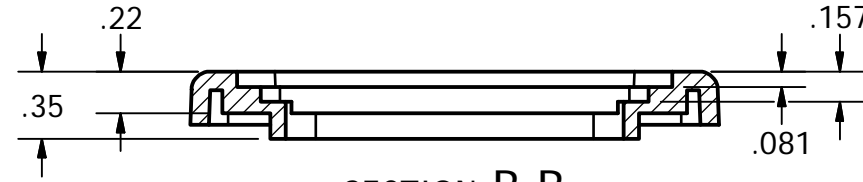

2. UNLESS OTHERWISE SPECIFIED DRAFT ANGE: 1°

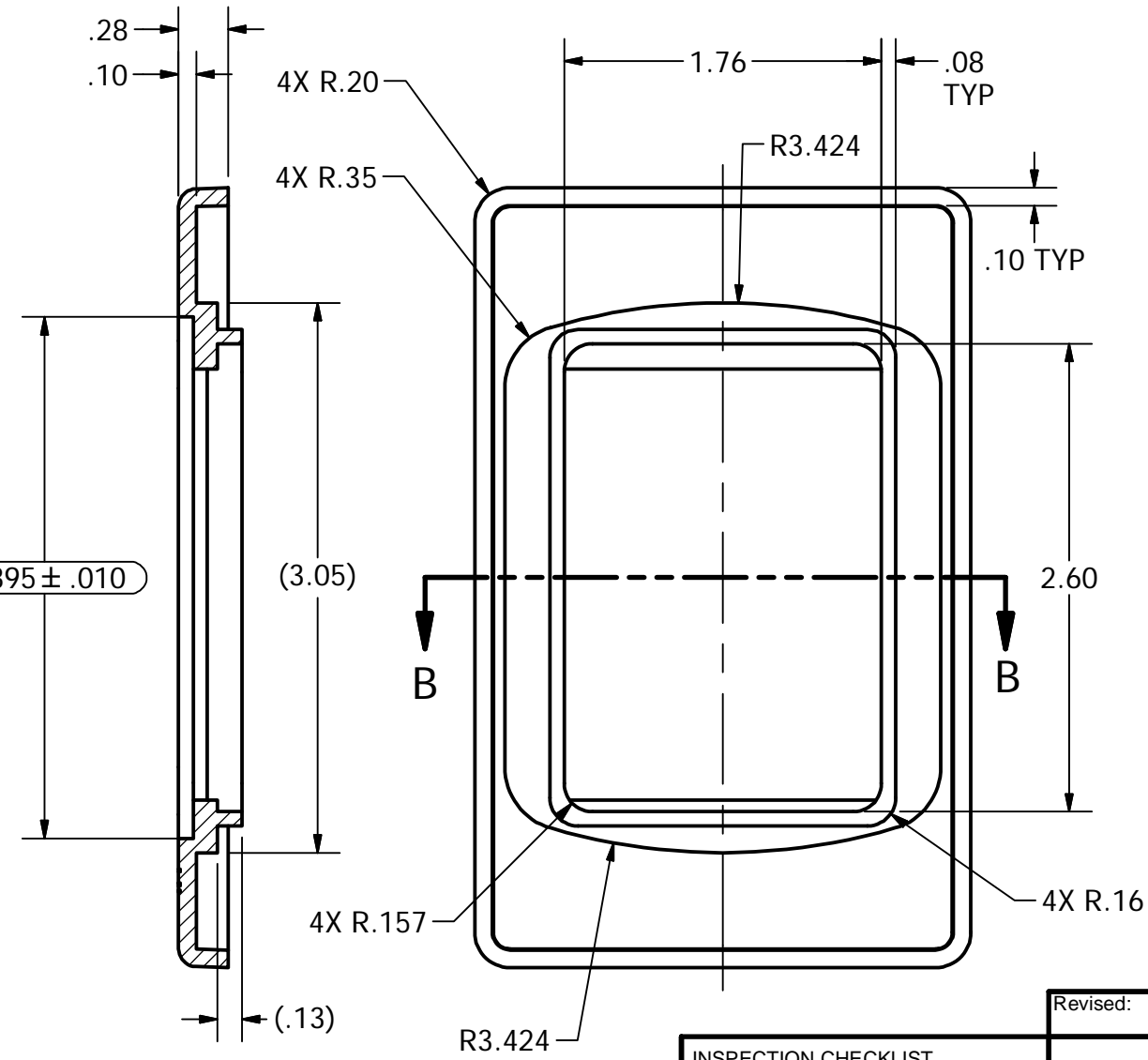
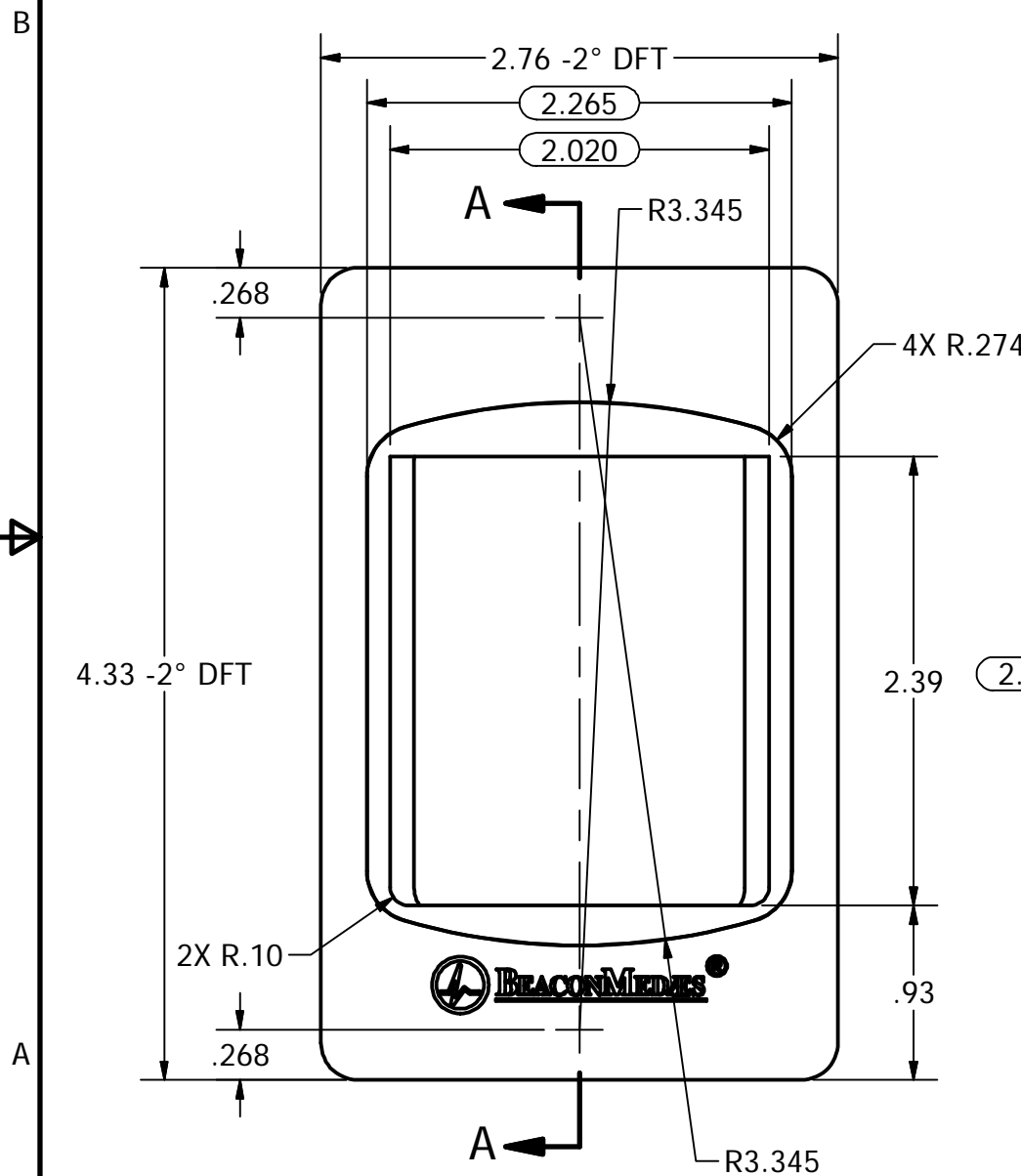
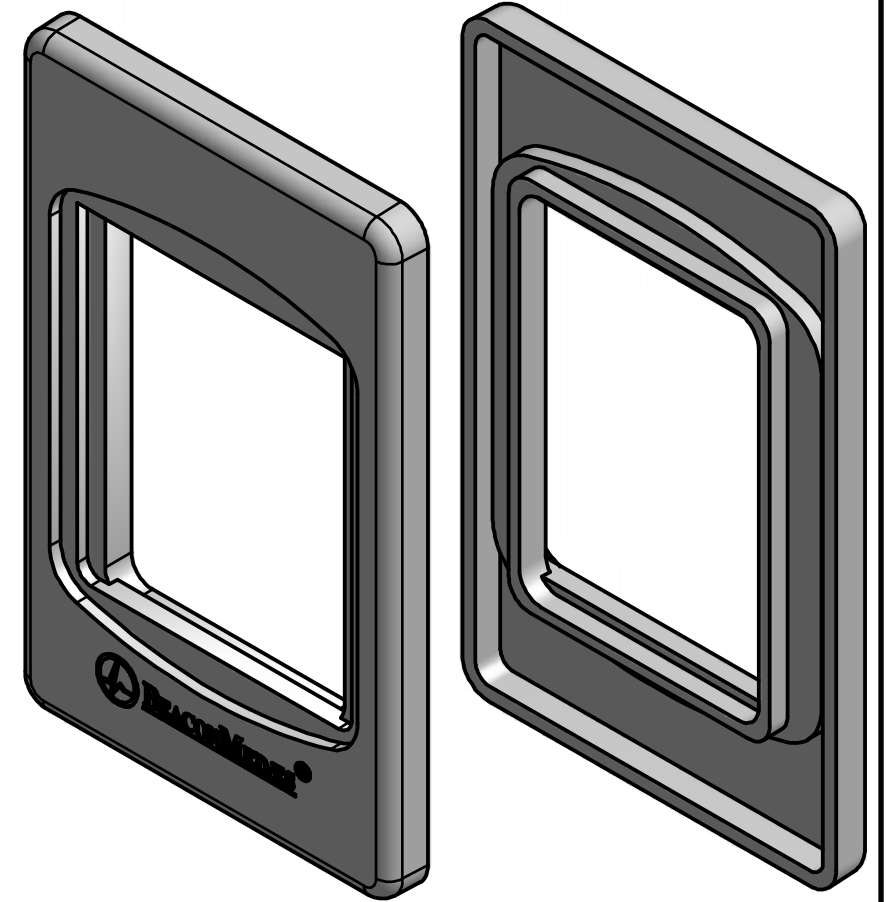

SECTION B-B



SECTION A-A

INSPECTION CHECKLIST  
UNLESS OTHERWISE SPECIFIED:  
   
 ALL ITEMS MARKED BY ONE OF THE ABOVE SYMBOLS ARE TO BE INSPECTED  
 EQUIPMENT TO BE USED DURING RECEIVING INSPECTION SHALL BE PER QUALITY SYSTEM PROCEDURES

Revised:	Date:	Drawn: USNKW	Date: 10/2/2012
		UNLESS OTHERWISE SPECIFIED ALL DIMENSIONS ARE IN INCHES AND TOLERANCES ARE: .XX ±.01 .XXX ±.005 .XXXX ±.0005 ANGLES ±.5	
Description: <b>TRIM PLATE, DIAMOND CARE OUTLET</b>		Drawing Number: <b>4107 6540 74</b>	
		DN: HOP121147	Rev: 00
Sheet 1 of 1		DO NOT SCALE THIS DOCUMENT	