

NOTE:

1. INTERPRET DIMENSIONS AND TOLERANCES PER ANSI Y14.5M.
2. MATERIAL:  
22 GA. (.030) ST STL.  
AISI TYPE 304 #4 FINISH
3. TOLERANCES:  
2 PL DEC.  $\pm .02$   
3 PL DEC.  $\pm .005$
4.  PROTECTIVELY COVER #4 FINISH SIDE ONLY.
5. PROTECTIVELY PACKAGE TO PREVENT NICKS AND SCRATCHES.
6. PARTS ARE TO BE FREE OF OIL AND GREASE.
7. DEBURR ALL SHARP EDGES AND HOLES.

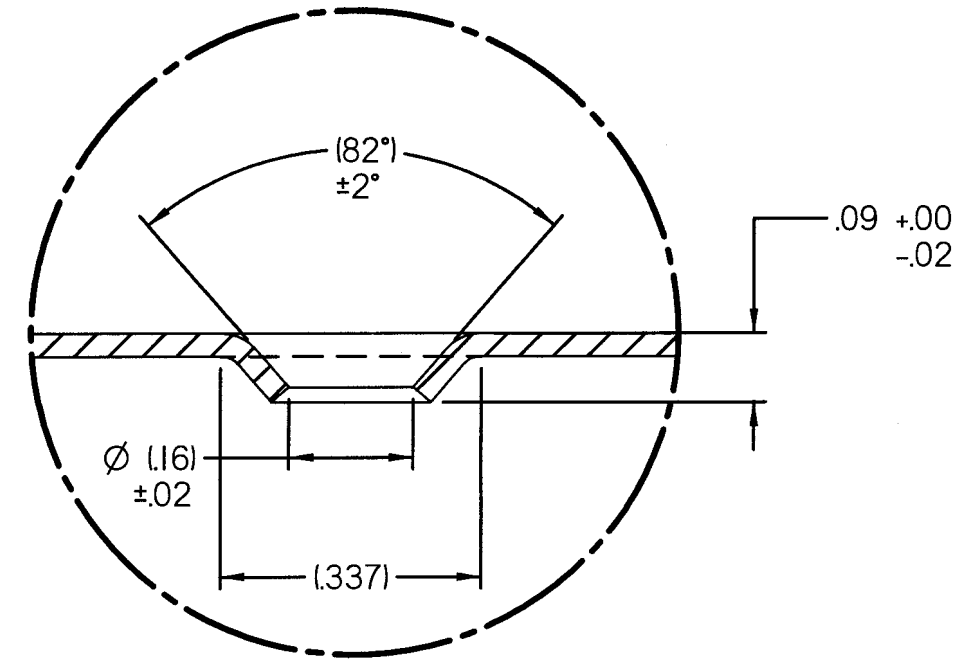

DETAIL B

SECTION A-A

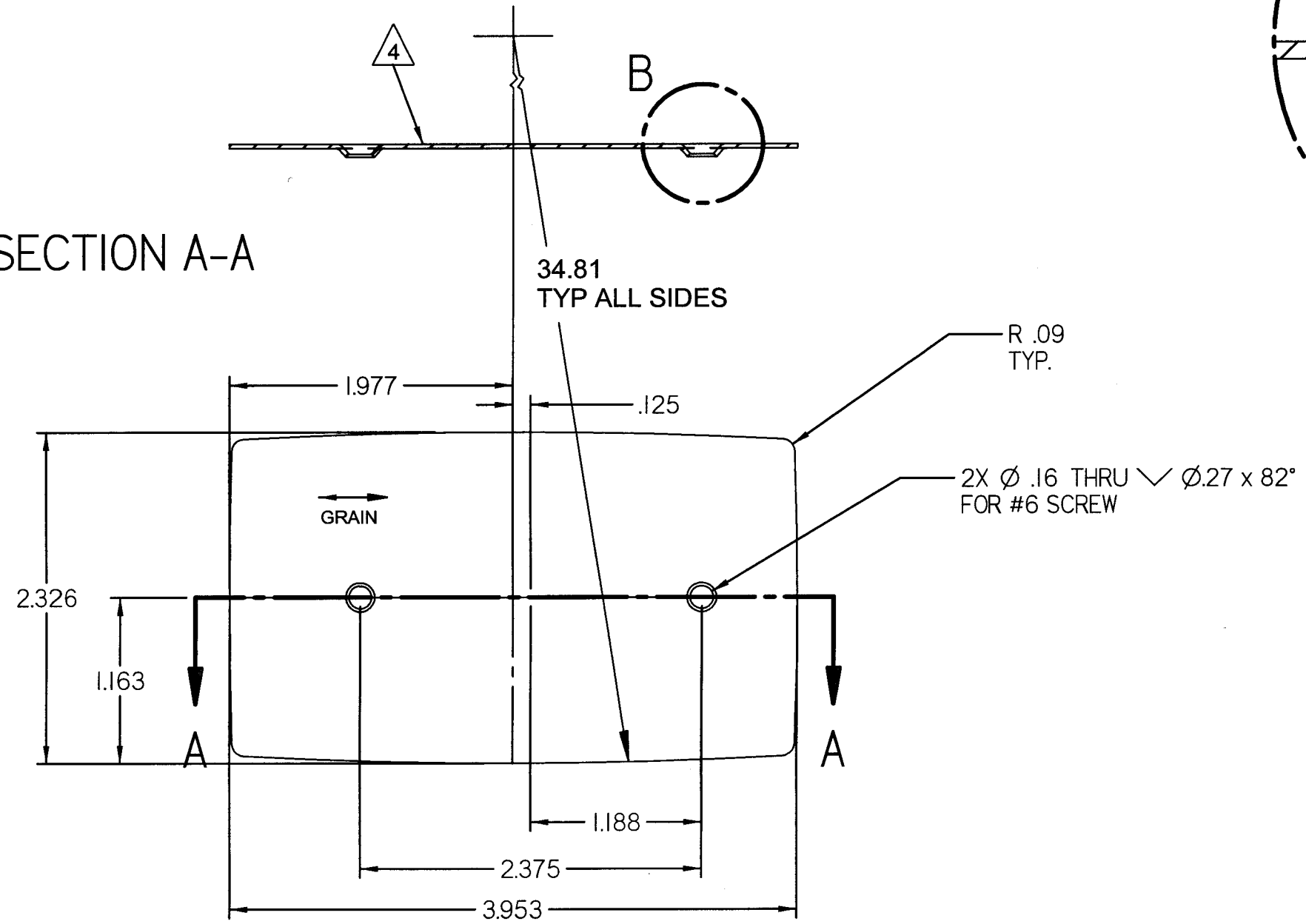

PREVIOUS P/N: 6803-1000-001.02

REV	REV DATE	CHANGE NO
00	01/04/2010	USN090193

NOTICE

THIS DRAWING AND ALL INFORMATION THEREON IS THE PROPERTY OF:

**Hill-Rom.**  
A HILLENBRAND INDUSTRY

THIS DRAWING AND INFORMATION THEREON, IS CONFIDENTIAL, MUST NOT BE MADE PUBLIC, COPIED OR USED TO DISADVANTAGE OF S&D HILL-ROM, INC. IT IS SUBJECT TO RETURN ON DEMAND. © 1999 Hill-Rom Co. Inc.

DESCRIPTION: <b>FINISH PLATE, BLANK W/MTG HOLES</b>	
DRAWN BY: B WOO	DATE DRAWN: 01/04/2010
SIZE: B	SHEET NO: 01 of 01
DWG NO: 4107 6521 44	